

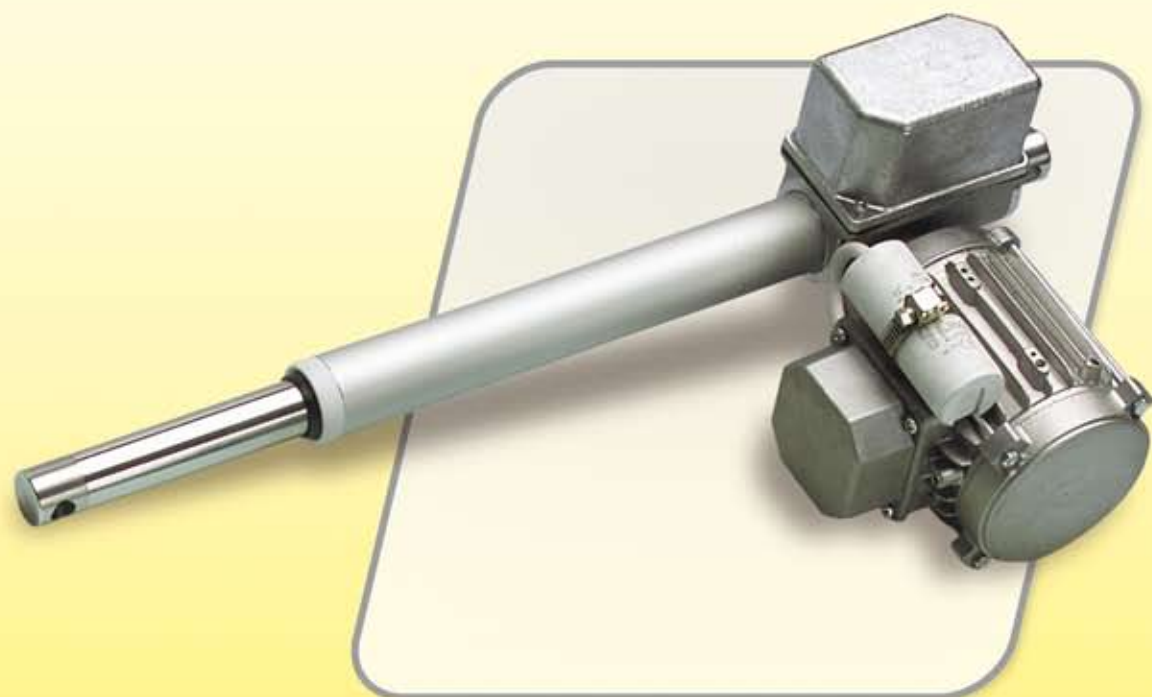

electromechanical actuators



Linear and rotative actuators

Catalogue Ed. 02/12

1. The Product	
1.1	Linearmech linear actuatorspage 2
1.2	Linearmech linear actuators rangepage 3
1.3	Manufacturing features.....page 5
1.4	Linear actuators selection criteriapage 6
2. Acme screw linear actuators LMR Series	
LMR 01	DC motorpage 8
LMR 02	DC motorpage 10
LMR 03	DC motorpage 12
3. Acme screw linear actuators ATL Series	
ATL 02	AC or DC motorpage 14
ATL 05	DC motorpage 16
ATL 08	DC motorpage 18
ATL 10	AC motorpage 20
	DC motorpage 22
ATL 12	AC motorpage 24
4. Acme screw linear actuators CLA Series	
CLA 20	AC or DC motorpage 26
CLA 25	AC motorpage 28
	DC motorpage 30
CLA 25 S, CLA 25 M	AC or DC motorpage 32
CLA 28	AC or DC motorpage 34
CLA 28 T	AC or DC motorpage 36
5. Acme screw linear actuator LMI 02	DC motorpage 38
6. Acme screw linear actuator LMP 03	DC motorpage 39
7. Acme screw linear actuator UAL 0	DC motorpage 40
8. Ball screw linear actuators BSA Series	
BSA 08	DC motorpage 42
BSA 10	AC or DC motorpage 44
BSA 11	AC or DC motorpage 48
BSA 12	AC motorpage 52
9. Ball screw linear actuators CLB Series	
CLB 25	AC or DC motorpage 54
CLB 27	AC or DC motorpage 58
10. Ball screw linear actuator UBA 0	DC motorpage 60
11. Gearmotors for rotative actuators	
MR 15	DC motorpage 63
MR 31	DC motorpage 64
MR 40 FC	DC motorpage 65
12. General Features	
12.1	Ball screwspage 66
12.2	Static and dynamic self-locking conditionspage 68
12.3	DC motorspage 69
12.4	AC motorspage 70
13. Stroke end switches and positioning control	
13.1	Magnetic stroke end reed switches FCM for linear actuators ATL and BSA Seriespage 72
13.2	Electric stroke end switches FCE for linear actuators ATL and BSA Seriespage 72
13.3	Electric stroke end switches FC for linear actuators LMR Series.....page 73
13.4	Electric stroke end switches and potentiometer FC+POR for linear actuators CLA Seriespage 74
13.5	Encoder GI.....page 75
13.6	Encoder EH38page 75
14. Controls and driverspage 76
14.1	LME 01 Electronic overload protectionpage 76
14.2	LME 02 Electronic dynamic brakingpage 77
14.3	LME 11 Single-actuator programmable driverpage 78
14.4	LME 12 Two-actuators programmable driverpage 79
15. Installation and Commissioningpage 80



1.1 LINEARMECH LINEAR ACTUATORS

Linearmech electromechanical linear actuators are motorized mechanical cylinders able to transform a rotary movement of a motor into a linear motion.

Able to work under push or pull load. Due to the mechanical resistance of their components, many actuators can support push loads higher than pull loads.

Their main characteristics are the high performance reliability, with or without load, and the low noise level.

Their installation is simple and not expensive: it requires just a front and rear hinging as for standard hydraulic and pneumatic cylinders.

They can effectively replace pneumatic and hydraulic cylinders being able to perform:

- Reliability in push-pull motion
- Accuracy in stopping position
- Position holding under load (self-locking)
- Energy consumption during operation only
- Easy installation; only power and control electrical cables are required
- High safety in load lifting (static self-locking and safety nut available)
- Safe operation even in very high or very low temperature conditions without risk of freezing or fire; electromechanical cylinders do not use air or oil under pressure

The wide range of sizes, stroke lengths, motor types, linear speeds and available accessories makes it easy to use these products not only in new applications but also to replace hydraulic and pneumatic cylinders, improving the solution in terms of performances and economical advantages.

Linearmech S.r.l. Technical Dpt. is available to carry out calculations, technical checks and norm certifications issue according to customer requirements.

The technical catalogue in PDF format and 3D/2D models of standard products selected with a configurator can be downloaded on our website www.linearmech.it. For customized products and dimensioned drawings, please contact: info@linearmech.it.

Linearmech S.r.l. offers:

- Complete range of **standard electromechanical linear actuators** as per catalogue.

The mounting is carried out upon customer's purchase order. All components are available on stock. This ensure very short delivery time and immediate availability in case of machine stop.

- **Customized electromechanical linear and rotative actuators.**

The customization is carried out according to customer specific requirements. It can involve simple modifications of existing models up to the design and execution of completely tailor-made products, exclusively manufactured for a specific customer.

On request, products can be marked with customized label.

Linearmech electro-mechanical actuators are totally manufactured in Italy in the plant located in Anzola dell'Emilia (Bologna). All components used in the production are of Italian manufacture.

As a matter of fact, the entire product can be defined as "Made in Italy", assuring a constant total quality, checked by professional and skilled personnel.



1.2 LINEARMECH ACTUATORS RANGE

Linearmech linear actuators range consists of two main product groups determined by their different linear drives:

- Acme screw linear actuators;
- Ball screw linear actuators.

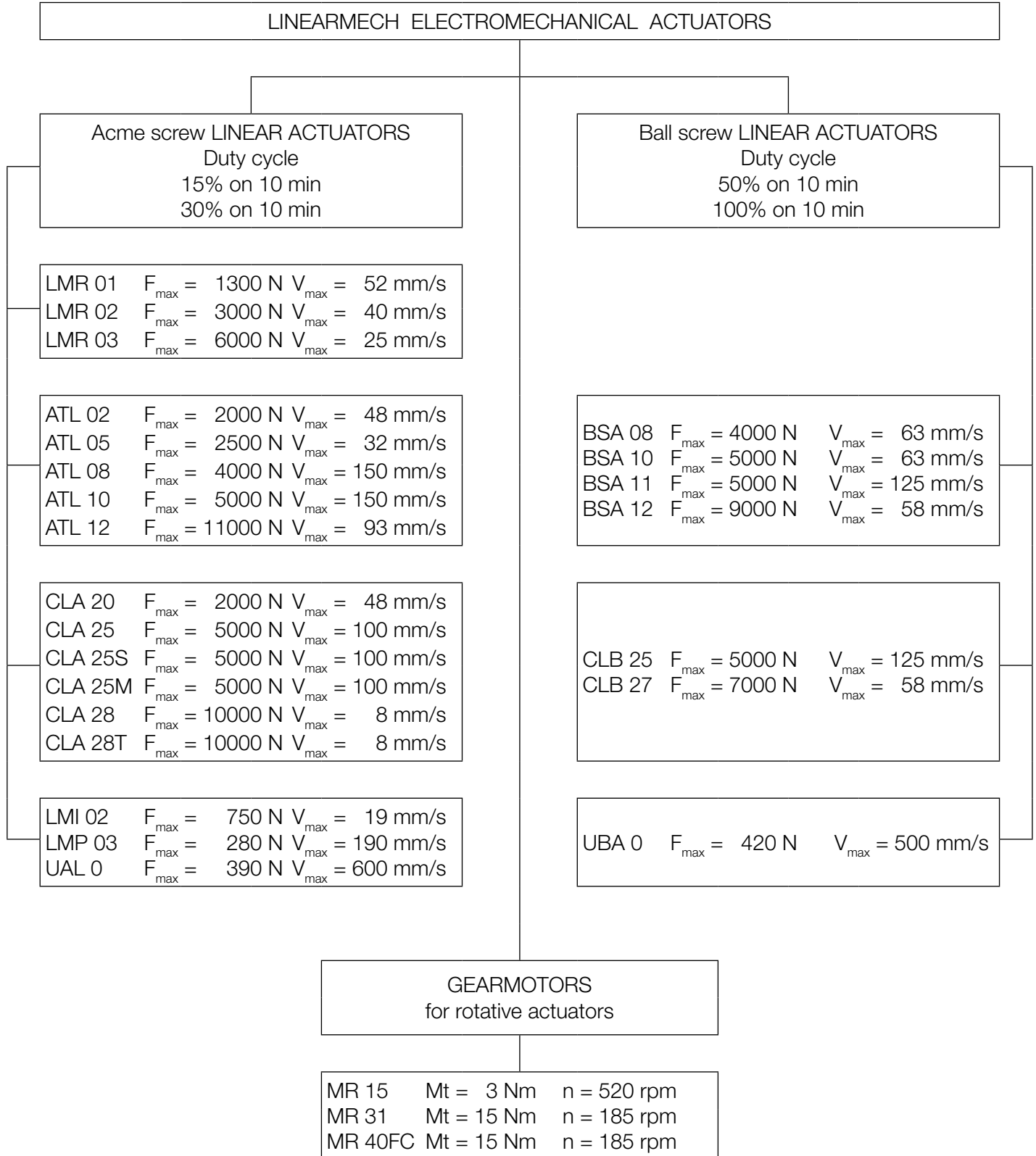



1.2 LINEARMECH ACTUATORS RANGE

LMR Series

Acme screw linear actuators, 3 sizes available. DC motor.
Built-in adjustable stroke end switches activated by self-keeping commutation devices.
Load capacity up to 6 000 N, linear speed up to 52 mm/s

ATL Series

Acme screw linear actuators, 5 sizes available. DC or AC 1-phase or 3-phase motors.
Adjustable stroke end magnetic reed switches and external adjustable stroke end electric switches.
Load capacity up to 11 000 N, linear speed up to 150 mm/s

CLA Series

Acme screw linear actuators, 6 sizes available. DC or AC 1-phase or 3-phase motors.
Adjustable electric cam-operated stroke end switches fitted in closed box.
Rotative potentiometer for positioning control.
Load capacity up to 10 000 N, linear speed up to 100 mm/s

LMI 02

Acme screw linear actuator with compact cylindrical shape, small overall dimensions. DC motor.
Max load 750 N, linear speed up to 20 mm/s

LMP 03

Acme screw linear actuator with motor mounted parallel to actuator axis. DC motor.
Max load 280 N, linear speed up to 190 mm/s

UAL 0

Acme screw linear actuator, timing belts and pulleys transmission, with parallel motor design. DC motor.
Adjustable stroke end magnetic reed switches.
Max load 390 N, linear speed up to 600 mm/s

BSA Series

Ball screw linear actuators, 4 sizes available. DC or AC 1-phase or 3-phase motors. Motor brake available.
Adjustable stroke end magnetic reed switches and external adjustable stroke end electric switches.
Load capacity up to 9 000 N, linear speed up to 125 mm/s

CLB Series

Ball screw linear actuators, 2 sizes available. DC or AC 1-phase or 3-phase motors. Motor brake available.
Adjustable electric cam-operated stroke end switches fitted in closed box.
Rotative potentiometer for positioning control.
Load capacity up to 7 000 N, linear speed up to 125 mm/s

UBA 0

Ball screw linear actuator, timing belts and pulleys transmission with motor mounted parallel to actuator axis.
DC motor. Adjustable stroke end magnetic reed switches.
Max. load 420 N, linear speed up to 500 mm/s

MR Series

Motorgears for rotative actuators. DC motor. Bi-directional, incremental encoder with 2 output channels
Adjustable electric cam-operated stroke end switches. Rotative potentiometer single turn 5 kOhm.

Linearmech linear actuators are totally manufactured in Italy and assembled in our plant located in Bologna. All materials used in the production are of Italian origin.

Methodical controls are carried out in-line during manufacturing process to monitor the production quality and functional checks are carried out on every finished assembled product to ensure the total quality and reliability of the final product.

Input drives

- Worm gear, geometric design for high performances and efficiency.
Worm shaft fitted or extracted directly on the electric motor shaft for a more compact and cost effective solution, allowing the integrated electric motor mounting on the actuator housing.
Helical wormwheel in bronze EN 1982 – CuSn12-C or in plastic material and high resistance Delrin® 500
- Timing pulleys UNI ISO 5294:1991 in aluminium for low inertia
Timing belts UNI ISO 5296-1:1991

Housing

- Casting in aluminium alloy EN 1706 AC-AISI9T6 machined with CNC machinery to ensure a high precision level.
- Die casting in aluminium EN 1706 AC-AISI11Cu2(Fe) machined in the bearing housing.

Trapezoidal acme screws Tr profile ISO 2901 ... ISO 2904

Material: steel C 43 (UNI 7847)

Rolled and subjected to straightening process to ensure the regular alignment in operation and avoiding undesirable noises and loss of efficiency.

Max pitch error ± 0.5 mm over 300 mm thread length

Bronze nuts Tr profile ISO 2901 ... ISO 2904

Material: Bronze EN 1982 – CuAl9 Tr 1-start
Bronze EN 1982 CuSn12 Tr 2 or 3 starts
Delrin® 500

Ball screws

Rolled and hardened, manufactured by Servomech SpA S.U.

Material: steel 42 CrMo 4 (UNI EN 10083)

Precision Class ISO IT 7

Max pitch error ± 0.5 mm over 300 mm thread length

Ball nuts

Manufactured by Servomech SpA S.U.

Material: steel 18 NiCrMo 5 (UNI EN 10084)

Hardened and ground

Microfinishing

Max axial backlash (0.07 \div 0.08)

Ball nut without play or pre-loaded on request

Push rods

- Material: Chrome plated steel ST 52 DIN 2391 - tolerance on outer diameter f7
- Anodized aluminium for small size actuators
- Push rods in stainless steel AISI 304 on request

Outer protective tubes

- Drawn profiles in aluminium EN AW 6060 T5
- Aluminium alloy tubes 6060 UNI 90005/1 anodizing 20 μ m
- Cold-drawn steel St 52.2 DIN 2391

Front and rear attachments

Wide range of options: clevis ends and ball joints

Both front and rear attachments are provided with self-lubricating bronze bushes to reduce frictions and sticking and to improve the efficiency (not available for small size actuators).

In order to select the most suitable linear actuator, it is first necessary to analyse the application to determine the required performances and the working conditions.

1. Basic performances required

- Stroke
- Push or pull load
- Linear speed

1.1 The load and the linear speed, if considered separately, determine the required type of linear actuator to be selected; if considered as contemporaneous performances they determine the required power and, therefore, the actuator's size.

1.2 The stroke length may influence the selection of the actuator's size only in case of very long stroke lengths and high push loads; in such a case, the buckling resistance of the screw should be checked. For more details and support, please contact our Technical Dpt.

2. Working and duty cycle

The single working cycle and the total actuator's duty cycle determine the choice of an actuator with acme screw or, alternatively, with ball screw.

The section "**Performances and Features**" states the duty cycle with max load admitted for each actuator.

The duty cycle, expressed in % over a 10 minutes period, is the percentage of time referred to 10 minutes, during which the actuator can operate under the maximum load conditions stated in this catalogue at (-10 ... +40) °C environment temperature.

Generally, the acme screw linear actuators can work with duty cycle of 15% or 30% over 10 minutes (depending on the electric motor type), while the ball screw linear actuators can work with duty cycle of 50% up to 100% (depending on the electric motor type).

For preliminary checks or any doubt concerning the selection, please contact our Technical Dpt.

3. Electric motor type

Depending on the series and the type, linear actuators are available with 12, 24 or 36 V DC motor or with AC 1-phase or 3-phase motor.

Some types of motors are available also with positioning or stopping brake.

The motors available for each actuator are stated in the specific section "**Performances and Features**" and in the table concerning the motors specifications at the end of this catalogue.



1.4 SELECTION CRITERIA

4. Accessories

Linearmech linear actuators are supplied with a wide range of accessories as indicated in the specific section “**Accessories**” for each actuator size:

- adjustable stroke end limit switches
- incremental bi-directional encoders with 2 output channels
- analogic rotative potentiometer
- brake motor
- overload electronic protection
- dynamic overload mechanical protection
- many type of front attachments
- rear fixing supports
- stainless steel push rod
- electronic dynamic braking device
- programmable drivers

5. Working environment conditions

The external environment conditions in which the actuator is working are particularly important and shall be considered and evaluated, since they may strongly influence the regular functioning and the lifetime of the linear actuator.

The standard equipment of the linear actuators as well as the stated protection level against water and dust, are sufficient to enable the regular functioning in the main industrial applications.

Nevertheless, we recommend to report particular working environment conditions such as:

- Outside use, without proper auxiliary protections;
- Environment temperature lower than -10 °C or higher than +40 °C;
- Dusty environment and with polluting substances;
- Environments which require strong washing with acid or basic solutions;
- Use with strong external induced vibrations.

Finally, we are convinced that there is always a solution to any problem; what is important is to highlight and to analyze the problem in advance.

Our Technical Dpt. is available to evaluate with you the best technical and economical solution.

OVERALL DIMENSIONS

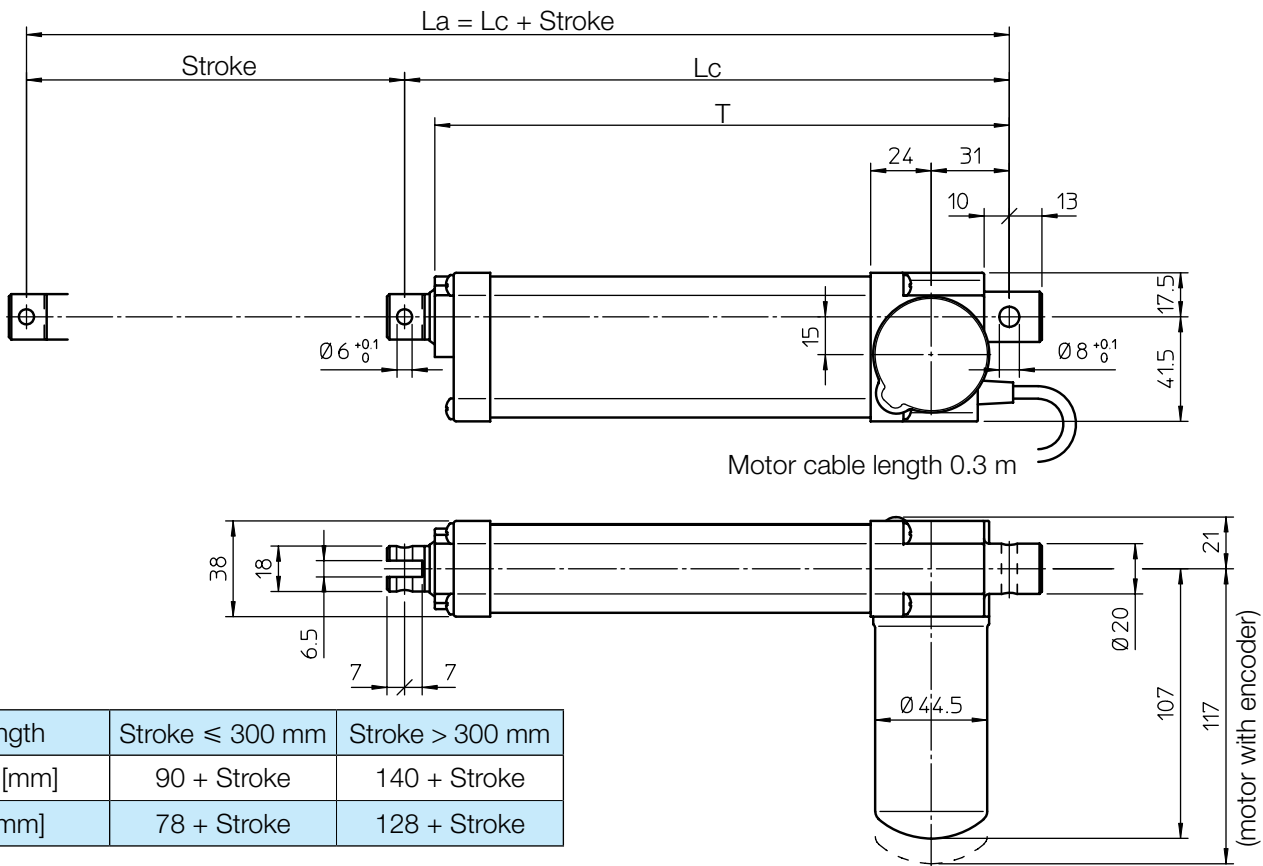

Length	Stroke \leq 300 mm	Stroke $>$ 300 mm
L_c [mm]	90 + Stroke	140 + Stroke
T [mm]	78 + Stroke	128 + Stroke

STROKE CODE	STROKE [mm]	LENGTH		MASS [kg]
		L_c [mm]	L_a [mm]	
C50	50	140	190	0.85
C100	100	190	290	1.10
C150	150	240	390	1.25
C200	200	290	490	1.40
C250	250	340	590	1.55
C300	300	390	690	1.70

PERFORMANCES AND FEATURES

- Pull-Push load up to 1 300 N
- Linear speed up to 52 mm/s
- Standard stroke lengths: 50, 100, 150, 200, 250, 300 mm (min. stroke limited by FC switches: 50 mm) (for different / longer stroke lengths please contact us)
- Aluminium housing and rear attachment
- Anodized aluminium push rod – tolerance f8
- Aluminium front attachment
- 12, 24 or 36 V DC motor with electromagnetic noise suppressor (motor features details on page 69)
- Duty cycle with max load: 15% over 10 min at (-10 ... +40) °C
- Standard motor mounting position as per dimensional drawing (right-hand, code RH)
- Standard protection IP65
 - Test IP6X according to EN 60529 §12 §13.4-13.6
 - Test IPX5 according to EN 60529 §14.2.5 (tests made with not running actuator)
- Long-life lubrication, maintenance free

ACCESSORIES

- Stainless steel push rod (code SS)
- Two adjustable built-in stroke end switches (code FC2)
- Two adjustable built-in stroke end switches, switching off the motor (code FC2X)
- Extra switch for intermediate position (code FC)
- 2-channels incremental encoder on motor shaft
 - 1 ppr (code GI 21)
 - 4 ppr (code GI 24)
 (wiring diagrams on page 75)

Number of pulses for 100 mm stroke	Ratio			
	RN2	RN1	RL2	RL1
GI 21	192	383	483	967
GI 24	767	1 533	1 933	3 867

OPTIONS

- Motor mounting position on opposite side (left-hand, code LH)
- Fixing attachment turned at 90° (code RPT 90)

PERFORMANCES with 24 V DC motor

(Performances with 12 V DC motor: same load, linear speed 10 % less, electrical consumption 2 times more)

1-start acme screw Tr 12x3

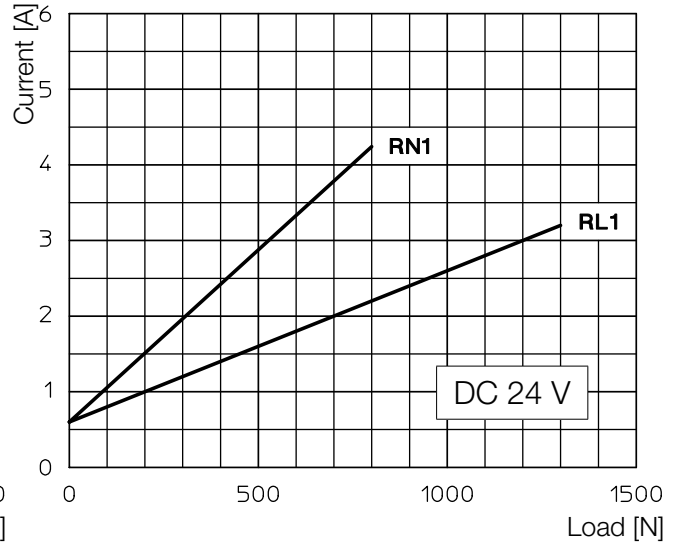
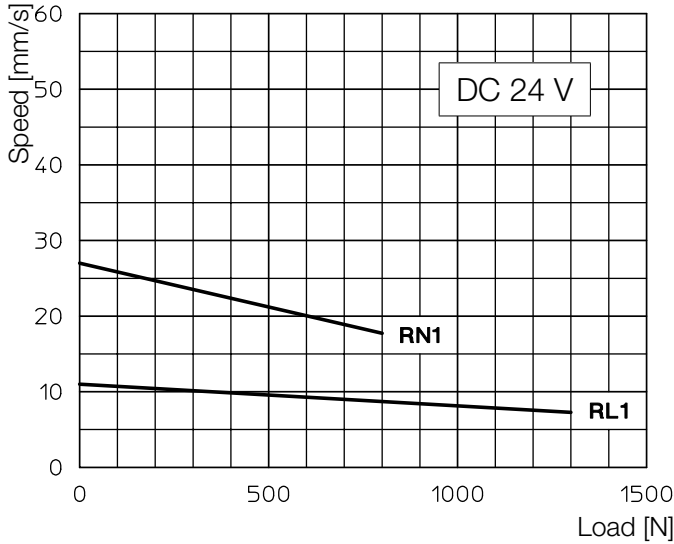

2-starts acme screw Tr 12x6 (P3)

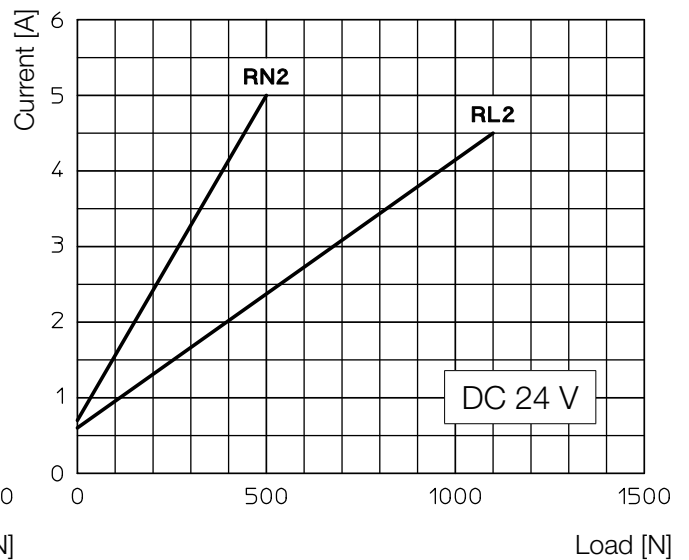
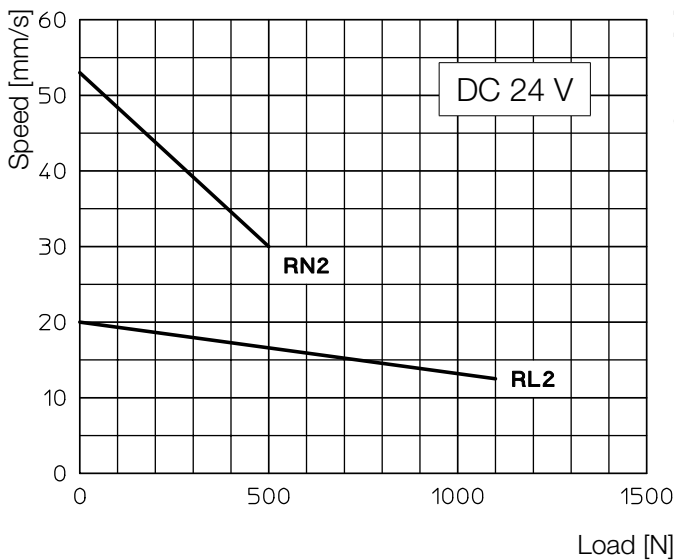

Self-locking conditions

Information about statically self-locking conditions with pull or push load on page 68.

ORDERING CODE EXAMPLE

LMR 01	RL1	C200	CC 24 V	FC2				
Actuator	Selected ratio	Required stroke	Motor	Stroke end switches	Accessories			Options

OVERALL DIMENSIONS

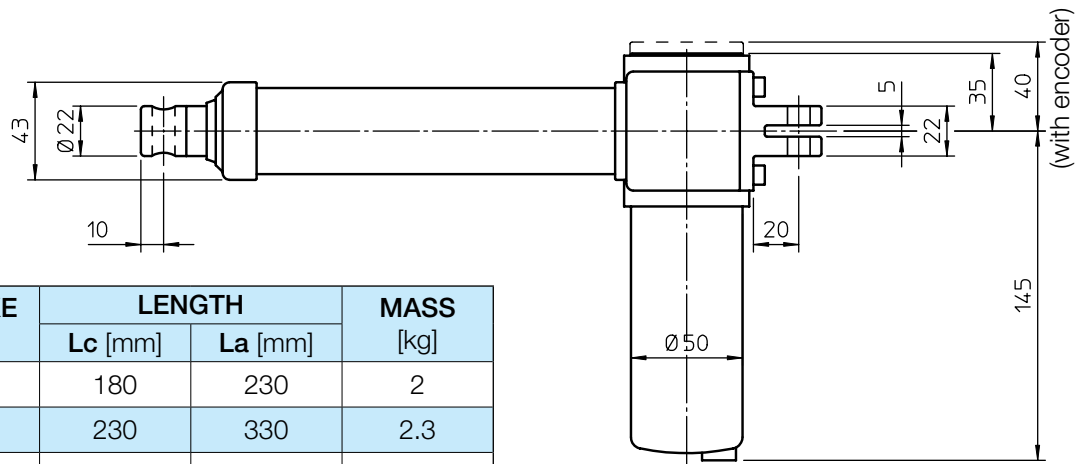
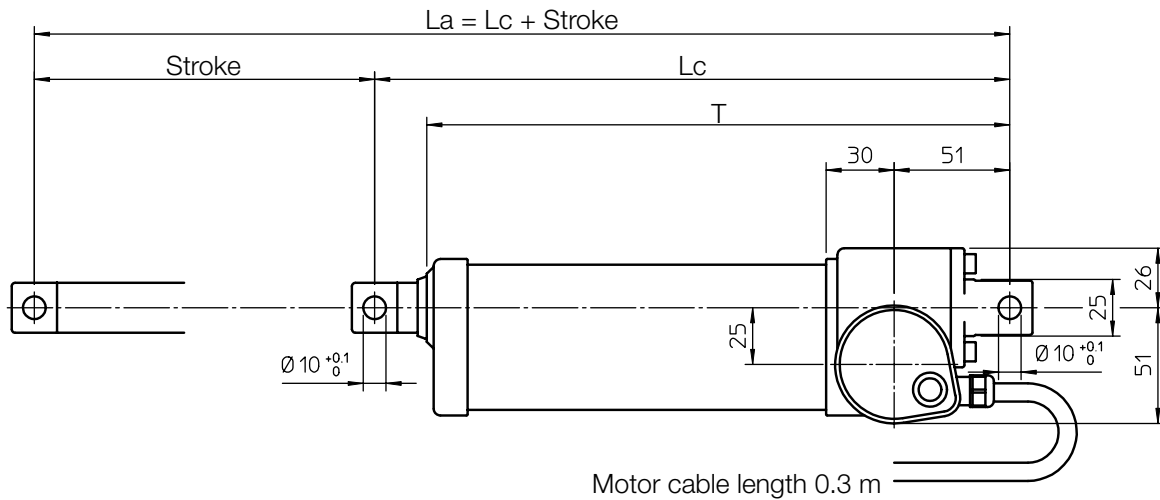

STROKE CODE	STROKE [mm]	LENGTH		MASS [kg]
		Lc [mm]	La [mm]	
C50	50	180	230	2
C100	100	230	330	2.3
C150	150	280	430	2.45
C200	200	330	530	2.6
C250	250	380	630	2.75
C300	300	430	730	2.9
C400	400	580	980	3.2

Length	Stroke \leq 300 mm	Stroke $>$ 300 mm
Lc [mm]	130 + Stroke	180 + Stroke
T [mm]	107 + Stroke	157 + Stroke

PERFORMANCES AND FEATURES

- Pull-Push load up to 3 000 N
- Linear speed up to 41 mm/s
- Standard stroke lengths: 50, 100, 150, 200, 250, 300, 400 mm (min. stroke limited by FC switches: 50 mm) (for different / longer stroke lengths please contact us)
- Aluminium housing and rear attachment
- Chrome-plated steel push rod
- Stainless steel AISI 303 front attachment
- 12, 24 or 36 V DC motor with electromagnetic noise suppressor (motor features details on page 69)
- Duty cycle with max. load: 15% over 10 min at (-10 ... +40) °C
- Standard motor mounting position as per dimensional drawing (right-hand, code RH)
- Standard protection IP65
 - Test IP6X according to EN 60529 §12 §13.4-13.6
 - Test IPX5 according to EN 60529 §14.2.5 (tests made with not running actuator)
- Long-life lubrication, maintenance free

ACCESSORIES

- Stainless steel push rod (code SS)
- Two adjustable built-in stroke end switches (code FC2)
- Two adjustable built-in stroke end switches, switching off the motor (code FC2X)
- Extra switch for intermediate position (code FC)
- 2-channels incremental encoder on motor shaft:
 - 1 ppr (code GI 21)
 - 4 ppr (code GI 24)
 (wiring diagrams on page 75)

Number of pulses for 100 mm stroke	Ratio			
	RN2	RN1	RL2	RL1
GI 21	246	492	775	1550
GI 24	984	1968	3100	6200

OPTIONS

- Motor mounting position on opposite side (left-hand, code LH)
- Fixing attachment turned at 90° (code RPT 90)

PERFORMANCES with 24 V DC motor

(Performances with 12 V DC motor: same load, linear speed 10 % less, electrical consumption 2 times more)

1-start acme screw Tr 14x4

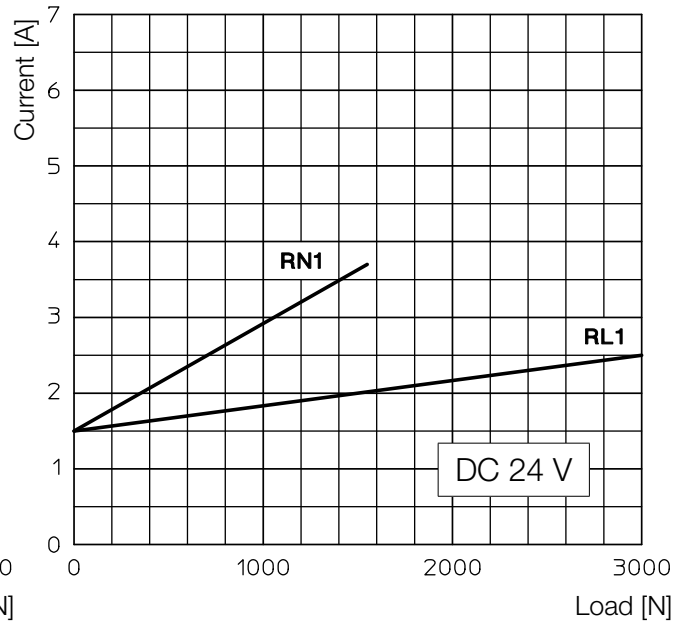
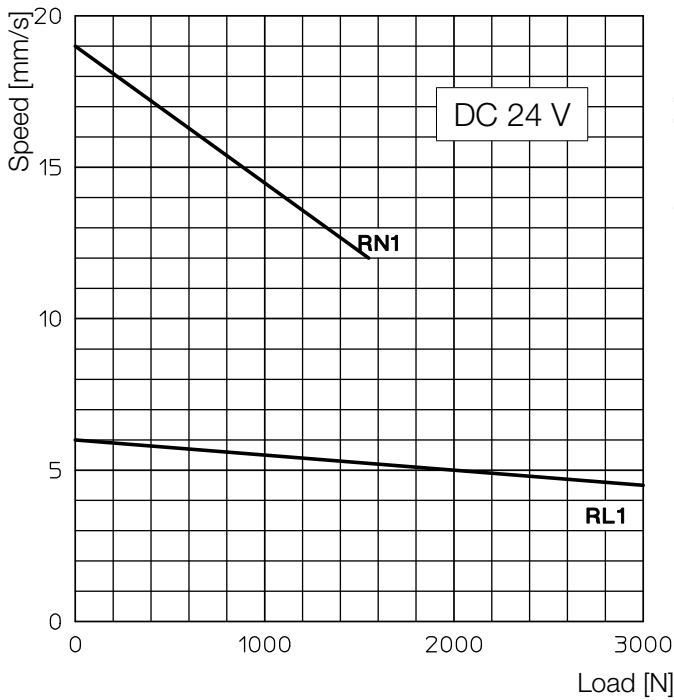

2-starts acme screw Tr 14x8 (P4)

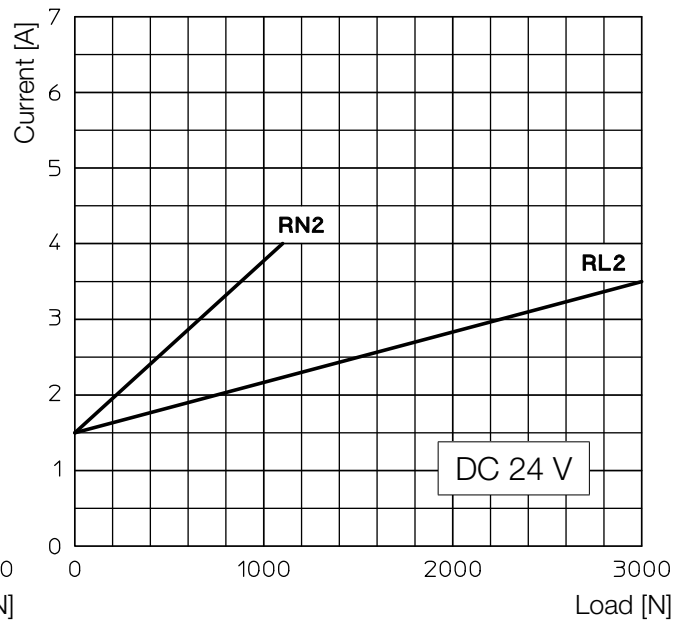
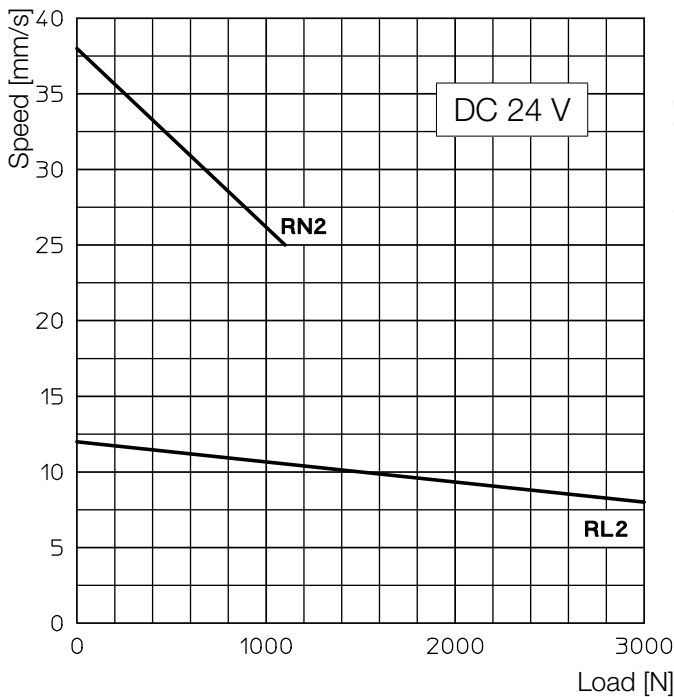

Self-locking conditions

Information about statically self-locking conditions with pull or push load on page 68.

ORDERING CODE EXAMPLE

LMR 02	RL1	C200	CC 24 V	FC2				
Actuator	Selected ratio	Required stroke	Motor	Stroke end switches	Accessories			Options

OVERALL DIMENSIONS

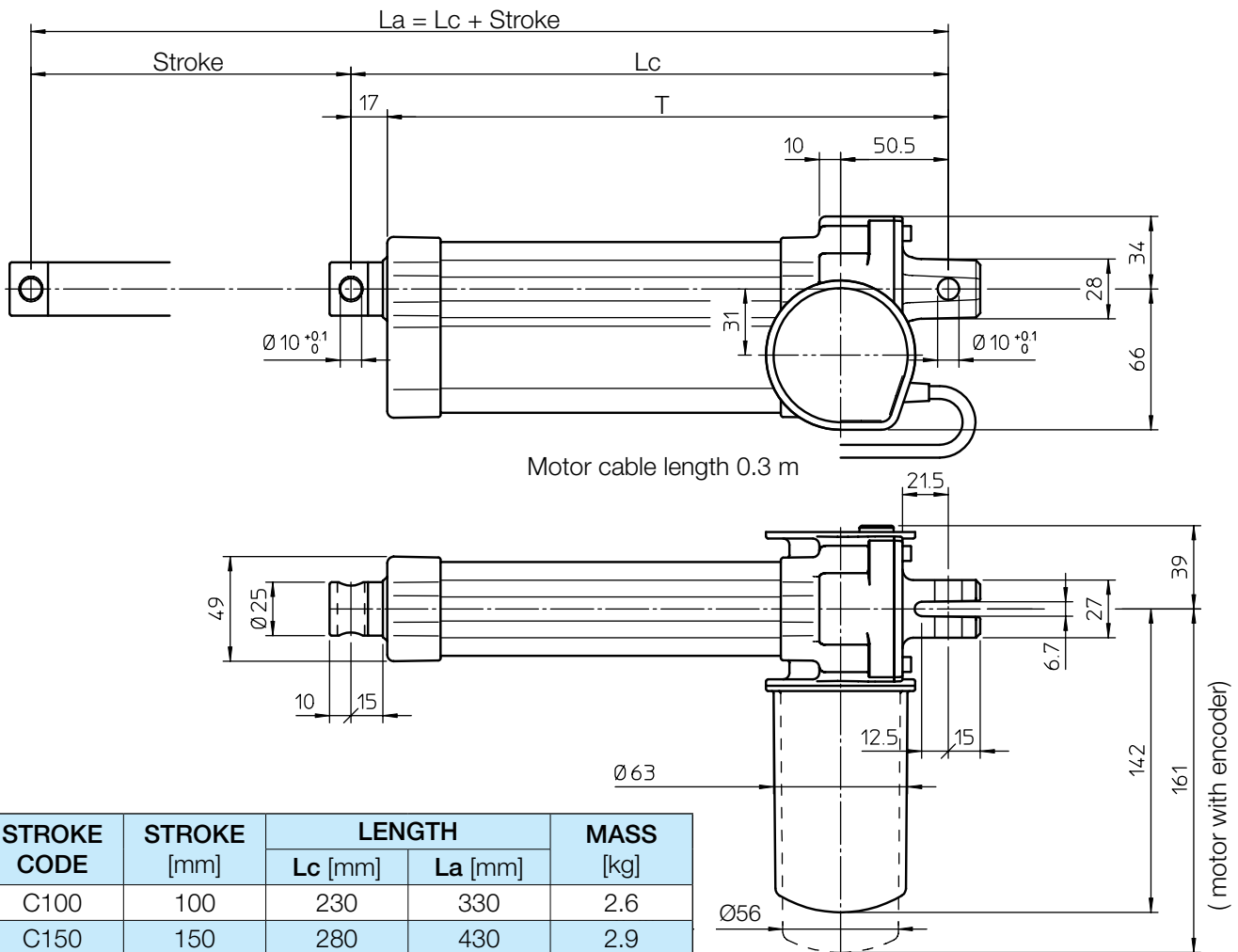

STROKE CODE	STROKE [mm]	LENGTH		MASS [kg]
		L_c [mm]	L_a [mm]	
C100	100	230	330	2.6
C150	150	280	430	2.9
C200	200	330	530	3.2
C250	250	380	630	3.5
C300	300	430	730	3.8
C400	400	580	980	4.7
C500	500	680	1180	5.3

Length	Stroke \leq 300 mm	Stroke $>$ 300 mm
L_c [mm]	130 + Stroke	180 + Stroke
T [mm]	113 + Stroke	163 + Stroke

PERFORMANCES AND FEATURES

- Pull-Push load up to 6 000 N
- Linear speed up to 25 mm/s
- Standard stroke lengths: 100, 150, 200, 250, 300, 400, 500 mm (min. stroke limited by FC switches: 50 mm) (for different / longer stroke lengths please contact us)
- Aluminium housing and rear attachment
- Chrome-plated steel push rod – tolerance f7
- Stainless steel AISI 303 front attachment
- 12, 24 or 36 V DC motor with electromagnetic noise suppressor (motor features details on page 69)
- Duty cycle with max. load: 15% over 10 min at (-10 ... +40) °C
- Standard motor mounting position as per dimensional drawing (right-hand, code RH)
- Standard protection IP65
 - Test IP6X according to EN 60529 §12 §13.4-13.6
 - Test IPX5 according to EN 60529 §14.2.5 (tests made with not running actuator)
- Long-life lubrication, maintenance free

ACCESSORIES

- Stainless steel push rod (code SS)
- Two adjustable built-in stroke end switches (code FC2)
- Two adjustable built-in stroke end switches, switching off the motor (code FC2X)
- Extra switch for intermediate position (code FC)
- 2-channels incremental encoder on motor shaft
 - 1 ppr (code GI 21)
 - 4 ppr (code GI 24)
 (wiring diagrams on page 75)

Number of pulses for 100 mm stroke	Ratio			
	RN2	RN1	RL2	RL1
GI 21	325	650	862	1 725
GI 24	1 300	2 600	3 450	6 900

OPTIONS

- Motor mounting position on opposite side (left-hand, code LH)
- Fixing attachment turned at 90° (code RPT 90)

PERFORMANCES with 24 V DC motor

(Performances with 12 V DC motor: same load, linear speed 10 % less, electrical consumption 2 times more)

1-start acme screw Tr 16x4

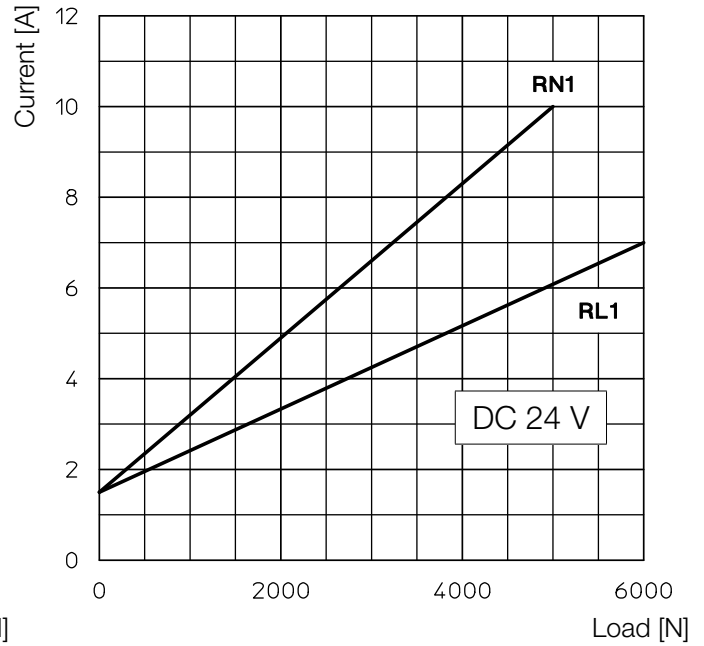
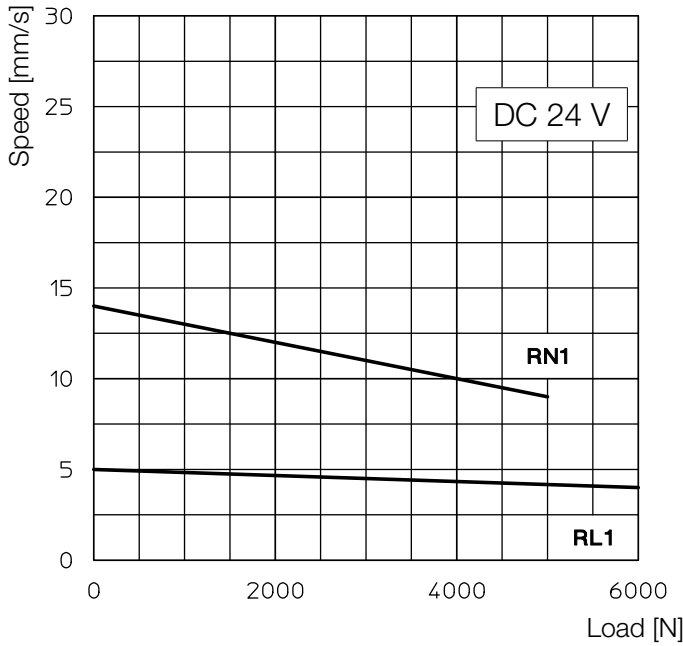

2-starts acme screw Tr 16x8 (P4)

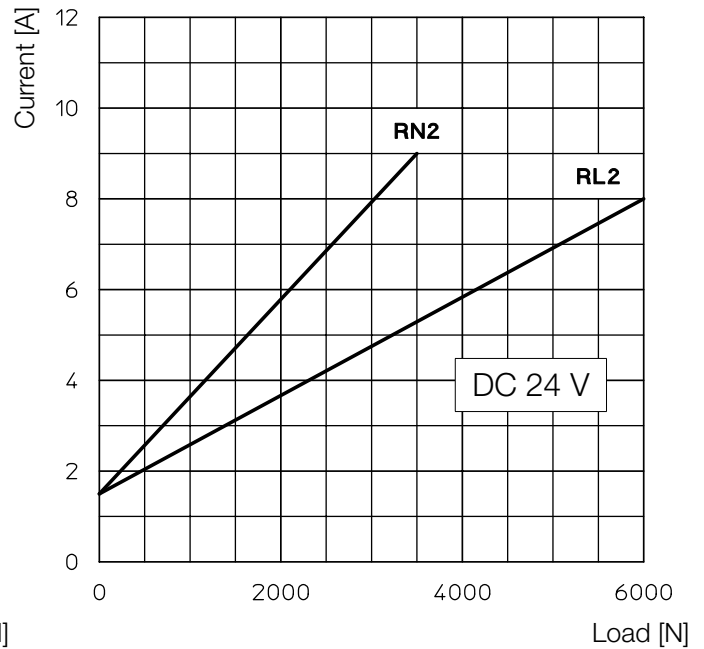
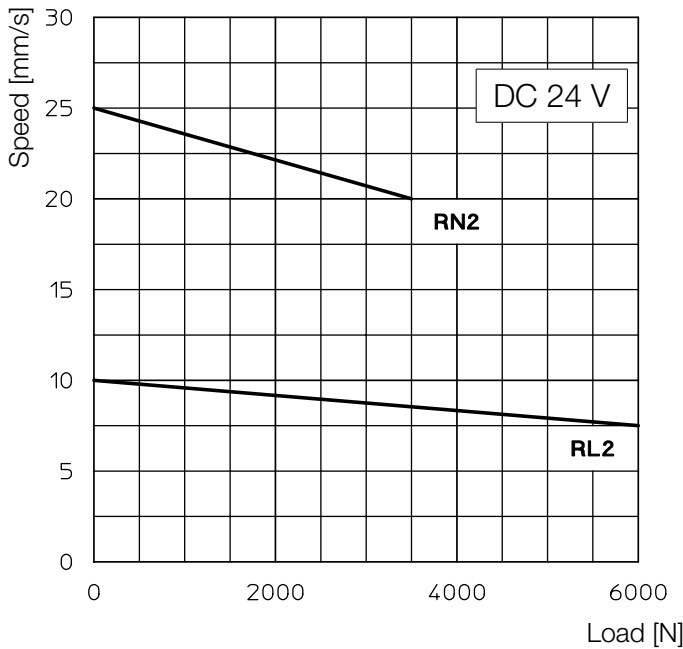

Self-locking conditions

Information about statically self-locking conditions with pull or push load on page 68.

ORDERING CODE EXAMPLE

LMR 03	RL1	C200	CC 24 V	FC2				
Actuator	Selected ratio	Required stroke	Motor	Stroke end switches	Accessories			Options

OVERALL DIMENSIONS

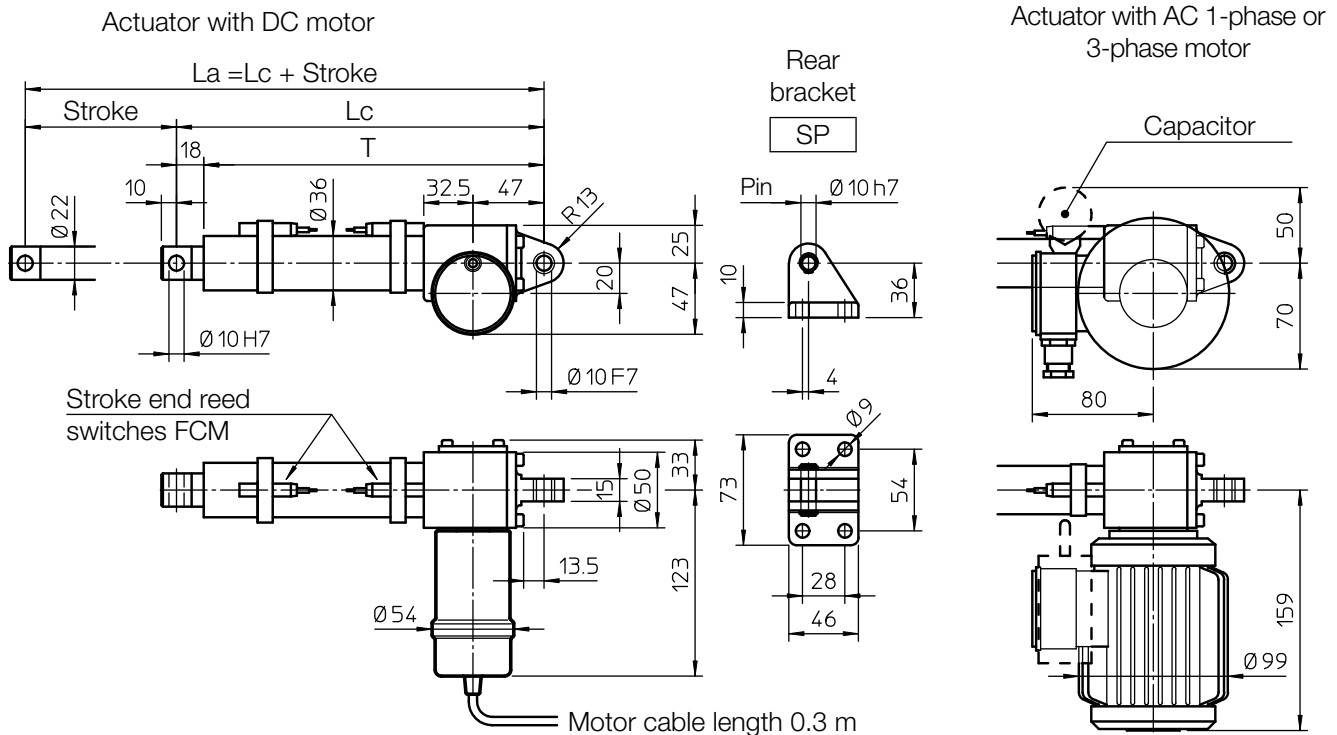

STROKE CODE	STROKE [mm]	LENGTH		T [mm]	MASS with DC motor [kg]	MASS with AC motor [kg]
		Lc [mm]	La [mm]			
C100	100	243	343	225	1.35	3.20
C150	150	293	443	275	1.60	3.45
C200	200	343	543	325	1.85	3.70
C300	300	443	743	425	2.10	3.95

Length	Stroke \leq 300 mm	Stroke $>$ 300 mm
Lc [mm]	143 + Stroke	158 + Stroke
T [mm]	125 + Stroke	125 + Stroke

PERFORMANCES AND FEATURES

- Pull-Push load up to 2 000 N
- Linear speed up to: 48 mm/s (DC motor)
30 mm/s (AC motor)
- Standard stroke lengths: 100, 150, 200, 300 mm (for different / longer stroke lengths please contact us)
- Aluminium alloy housing and rear attachment, with bronze bush
- Anodized aluminium outer tube
- Anodized aluminium push rod – tolerance h8
- Stainless steel AISI 303 front attachment
- Motors: (motor features details on page 69 and 70)
 - 12 or 24 V DC motor with permanent magnets
 - AC 3-phase or 1-phase motor
- Duty cycle with max load:
 - DC motor max.15% over 10 min at (-10 ... +40) °C
 - AC motor max.30% over 10 min at (-10 ... +40) °C
- Standard motor mounting position as per sketch (right-hand, code RH)

- Standard protection:
 - with DC motor IP65
 - Test IP6X according to EN 60529 §12 §13.4-13.6
 - Test IPX5 according to EN 60529 §14.2.5
 - with AC motor IP55
 - (tests made with not running actuator)
- Long-life lubrication, maintenance free

ACCESSORIES

- Stainless steel push rod (code SS)
- Rear bracket (code SP)
- Two adjustable stroke end reed switches (code FCM)
- Extra switches for intermediate positions

OPTIONS

- Motor mounting position on opposite side (left-hand, code LH)
- Fixing attachment turned at 90° (code RPT 90)

PERFORMANCES with AC 3-phase 50 Hz 230/400 V or 1-phase 50 Hz 230 V motor

1-start acme screw Tr 13.5×3		
0.06 kW - 2 pole motor		
RATIO	LOAD [N]	SPEED [mm/s]
RN1	1500	11
RL1	2000	5.5

2-starts acme screw Tr 14×8 (P4)		
0.06 kW - 2 pole motor		
RATIO	LOAD [N]	SPEED [mm/s]
RN2	1000	30
RL2	1100	15

PERFORMANCES with 24 V DC motor

(Performances with 12 V DC motor: same load, linear speed 10 % less, electrical consumption 2 times more)

1-start acme screw Tr 13.5×3

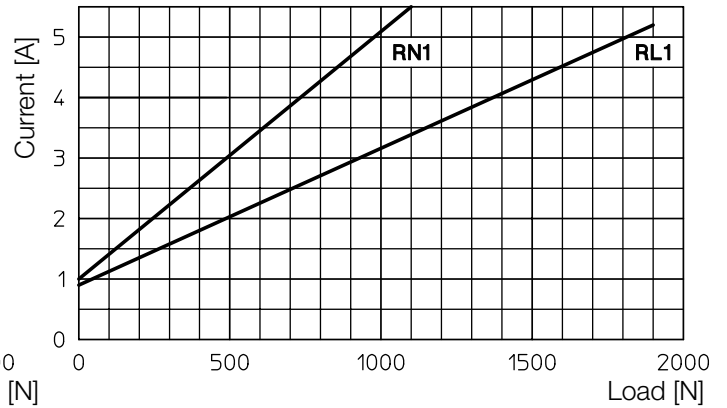
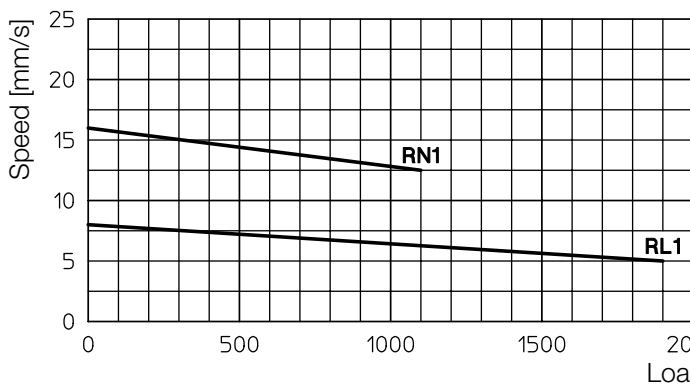

2-starts acme screw Tr 14×8 (P4)

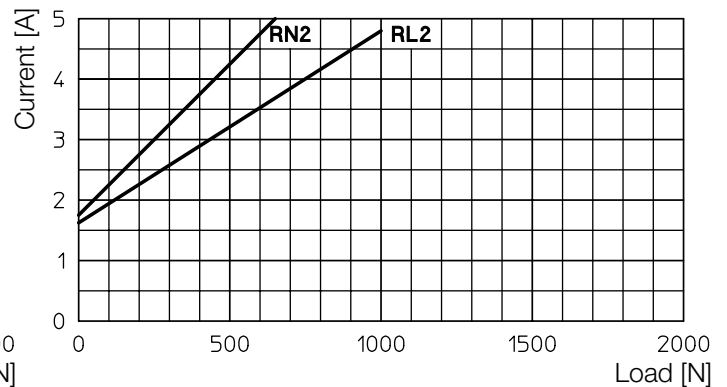
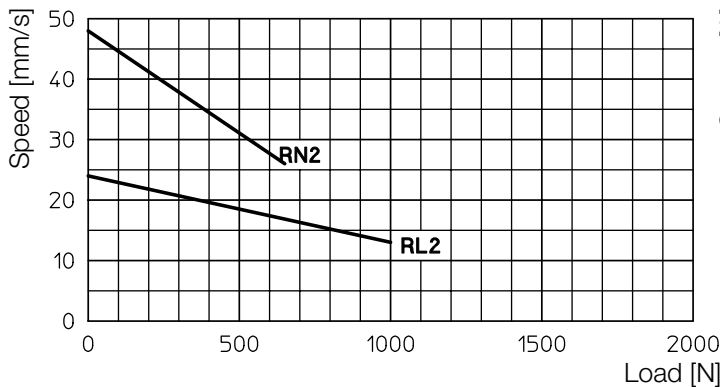

Self-locking conditions

Information about statically self-locking conditions with pull or push load on page 68.

ORDERING CODE EXAMPLE

ATL 02	RL1	C200	CC 24 V	FCM				
Actuator	Selected ratio	Required stroke	Motor	Stroke end switches	Accessories			Options

OVERALL DIMENSIONS

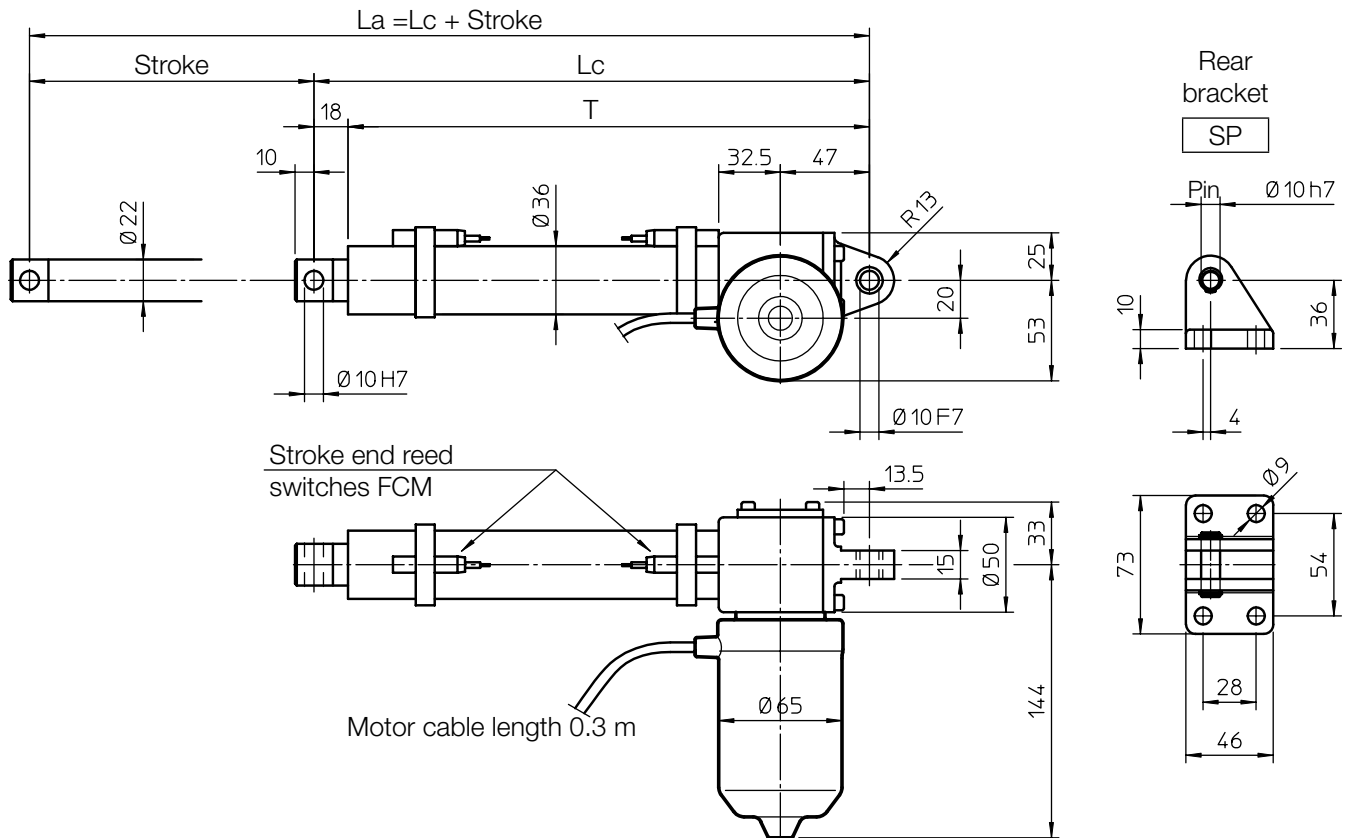

STROKE CODE	STROKE [mm]	LENGTH		T [mm]	MASS [kg]
		Lc [mm]	La [mm]		
C100	100	243	343	225	2.00
C150	150	293	443	275	2.25
C200	200	343	543	325	2.50
C300	300	443	743	425	2.75

Length	Stroke \leq 300 mm	Stroke $>$ 300 mm
Lc [mm]	143 + Stroke	158 + Stroke
T [mm]	125 + Stroke	125 + Stroke

PERFORMANCES AND FEATURES

- Pull-Push load up to 2 500 N
- Linear speed up to 32 mm/s
- Standard stroke lengths: 100, 150, 200, 300 mm (for different / longer stroke lengths please contact us)
- Aluminium alloy housing and rear attachment, with bronze bush
- Anodized aluminium outer tube
- Anodized aluminium push rod – tolerance h8
- Stainless steel AISI 303 front attachment
- 12, 24 or 36 V DC motor with electromagnetic noise suppressor (motor features details on page 69)
- Duty cycle with max load: 15% over 10 min at (-10 ... +40) °C
- Standard motor mounting position as per sketch (right-hand, code RH)

- Standard protection IP65
 - Test IP6X according to EN 60529 §12 §13.4-13.6
 - Test IPX5 according to EN 60529 §14.2.5 (tests made with not running actuator)
- Long-life lubrication, maintenance free

ACCESSORIES

- Stainless steel push rod (code SS)
- Rear bracket (code SP)
- Two adjustable stroke end reed switches (code FCM)
- Extra switches for intermediate positions

OPTIONS

- Motor mounting position on opposite side (left-hand, code LH)
- Fixing attachment turned at 90° (code RPT 90)

PERFORMANCES with 24 V DC motor

(Performances with 12 V DC motor: same load, linear speed 10 % less, electrical consumption 2 times more)

1-start acme screw Tr 13.5x3

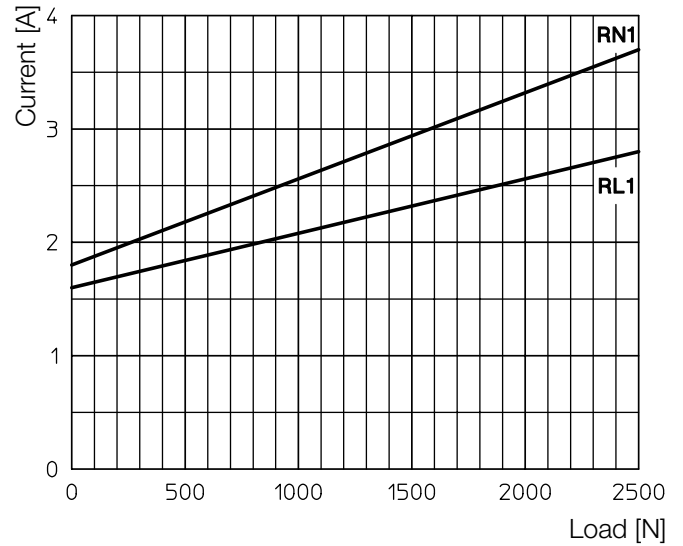
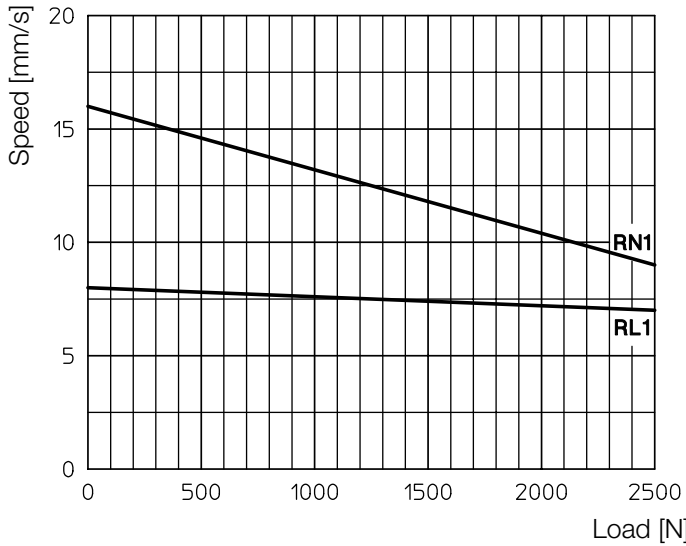

2-starts acme screw Tr 14x8 (P4)

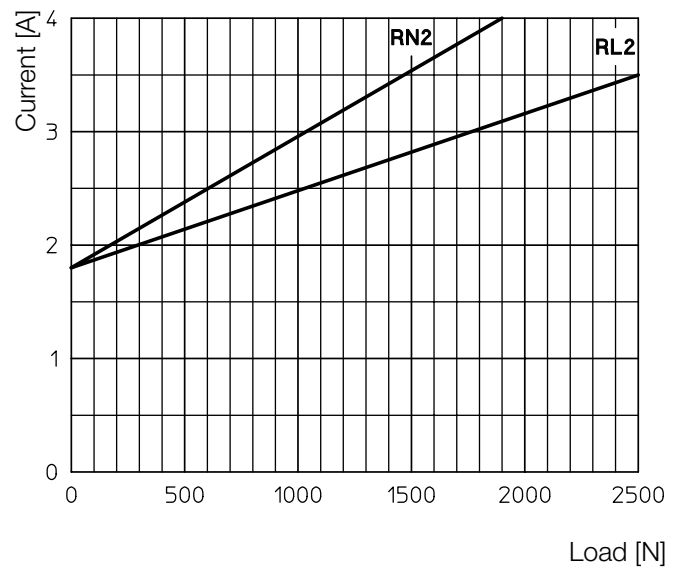
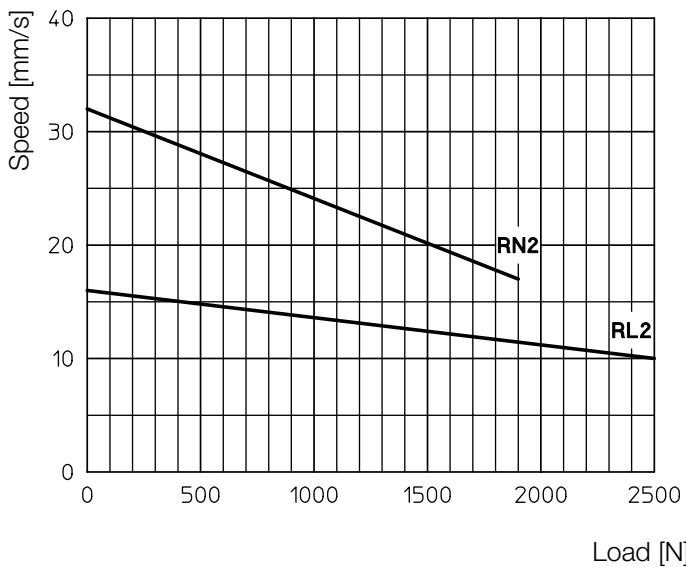

Self-locking conditions

Information about statically self-locking conditions with pull or push load on page 68.

ORDERING CODE EXAMPLE

ATL 05	RL1	C200	CC 24 V	FCM				
Actuator	Selected ratio	Required stroke	Motor	Stroke end switches	Accessories			Options

OVERALL DIMENSIONS

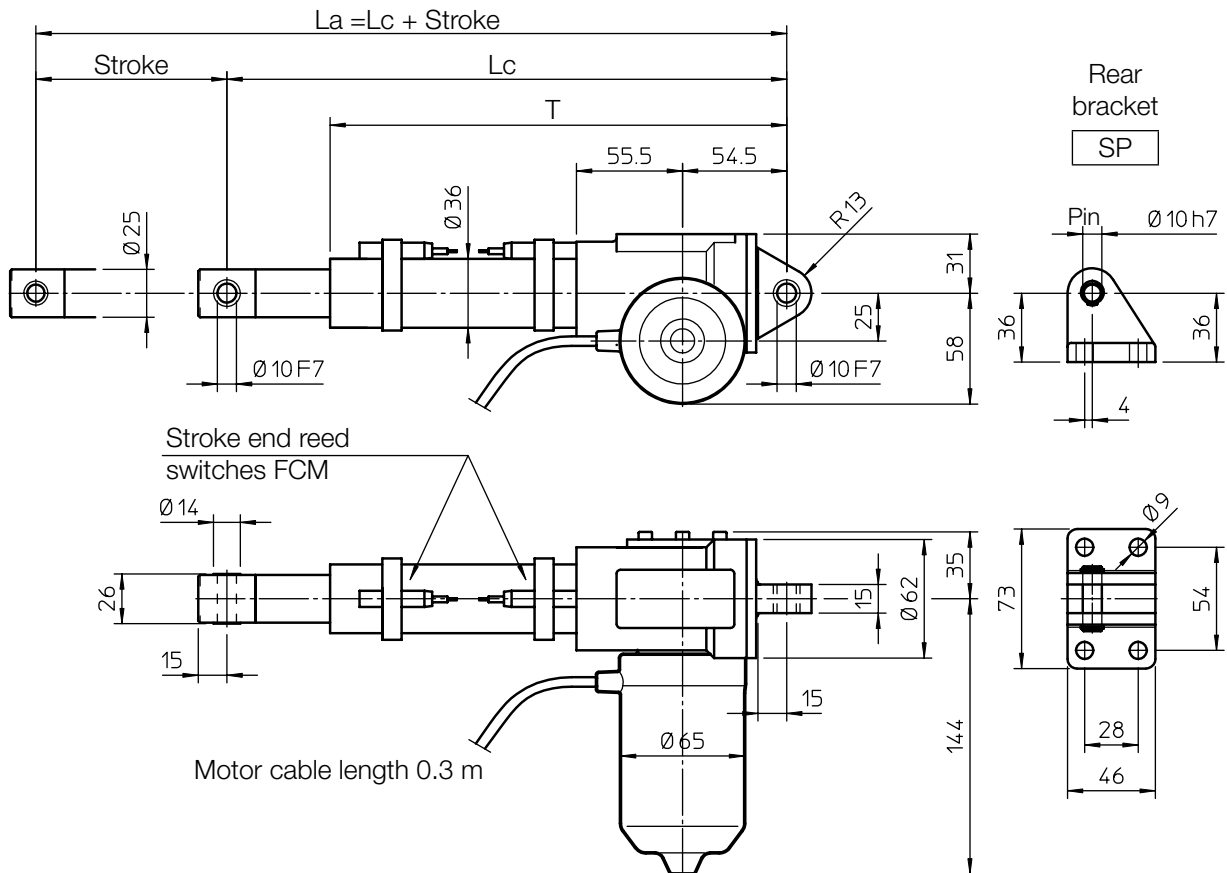

STROKE CODE	Actuator without FCM			Actuator with FCM			T [mm]	MASS [Kg]
	STROKE [mm]	LENGTH		STROKE [mm]	LENGTH			
		Lc [mm]	La [mm]		Lc [mm]	La [mm]		
C100	100	266	366	73	293	366	239	3.5
C150	150	316	466	123	343	466	289	3.7
C200	200	366	566	173	393	566	339	3.8
C300	300	466	766	273	493	766	439	4.1
C400	400	566	966	373	593	966	539	4.4
C500	500	666	1166	473	693	1166	639	4.7

PERFORMANCES AND FEATURES

- Pull-Push load up to 4 000 N
- Linear speed up to 150 mm/s
- Standard stroke lengths: 100, 150, 200, 300, 400, 500 mm (for different / longer stroke lengths please contact us)
- Aluminium alloy housing and rear attachment, with bronze bush
- Anodized aluminium outer tube
- Chrome-plated steel push rod – tolerance f7
- Stainless steel AISI 303 front attachment
- 12, 24 or 36 V DC motor with electromagnetic noise suppressor (motor features details on page 69)
- Duty cycle with max. load: 15% over 10 min at (-10 ... +40) °C
- Standard motor mounting position as per sketch (right-hand, code RH)
- Standard protection IP65
 - Test IP6X according to EN 60529 §12 §13.4-13.6
 - Test IPX5 according to EN 60529 §14.2.5 (tests made with not running actuator)
- Long-life lubrication, maintenance free

Length	with FCE	with FCM
Lc [mm]	166 + Stroke	220 + Stroke
T [mm]	139 + Stroke	166 + Stroke

ACCESSORIES

- Stainless steel push rod (code SS)
- Mechanical overload protection: safety clutch (code FS)
- Rear bracket (code SP)
- Two adjustable stroke end reed switches (code FCM)
- Extra switches for intermediate positions

OPTIONS

- Motor mounting position on opposite side (left-hand, code LH)
- Fixing attachment turned at 90° (code RPT 90)

PERFORMANCES with 24 V DC motor

(Performances with 12 V DC motor: same load, linear speed 10 % less, electrical consumption 2 times more)

1-start acme screw Tr 14x4

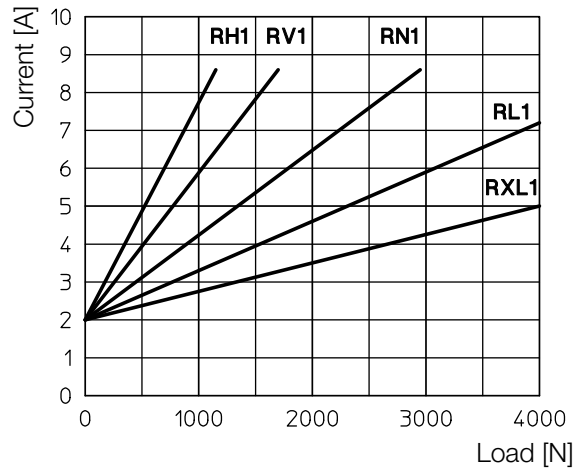
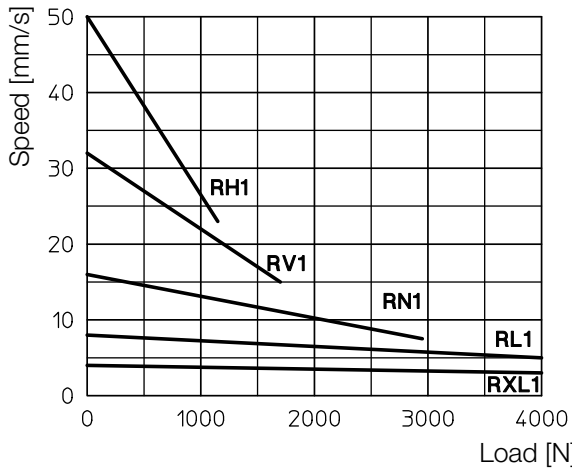

2-starts acme screw Tr 14x8 (P4)

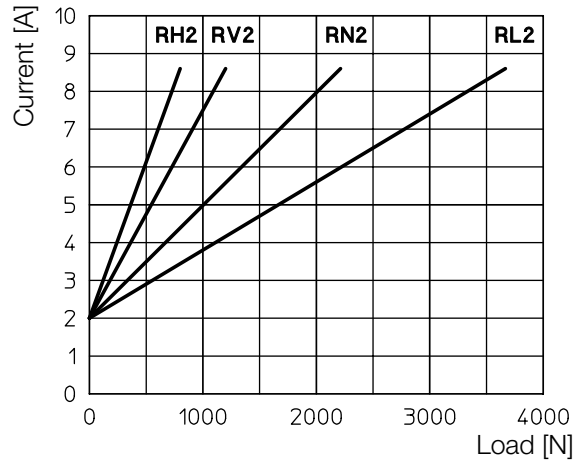
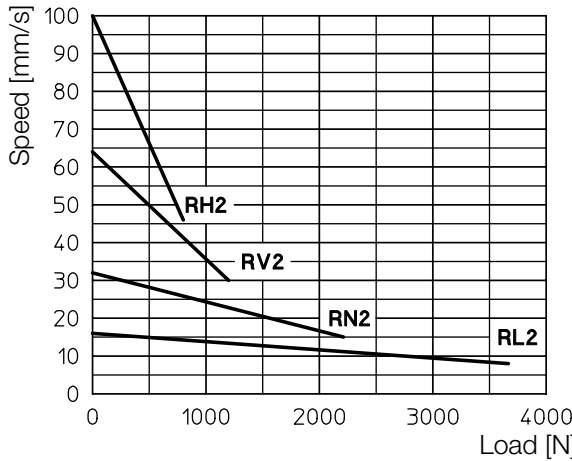

3-starts acme screw Tr 14x12 (P4)

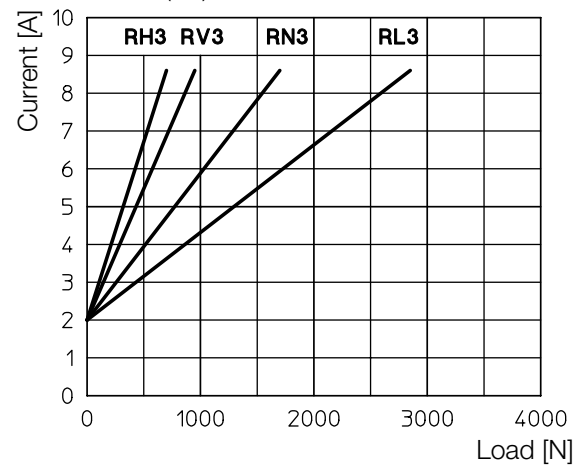
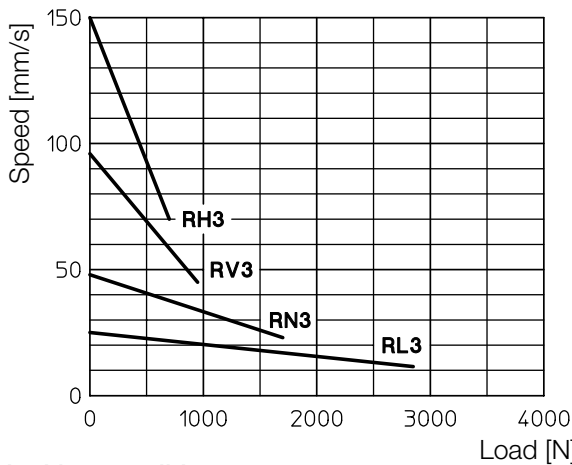

Self-locking conditions

Information about statically self-locking conditions with pull or push load on page 68.

ORDERING CODE EXAMPLE

ATL 08	RL1	C200	CC 24 V	FCM			
Actuator	Selected ratio	Required stroke	Motor	Stroke end switches	Accessories		Options

OVERALL DIMENSIONS

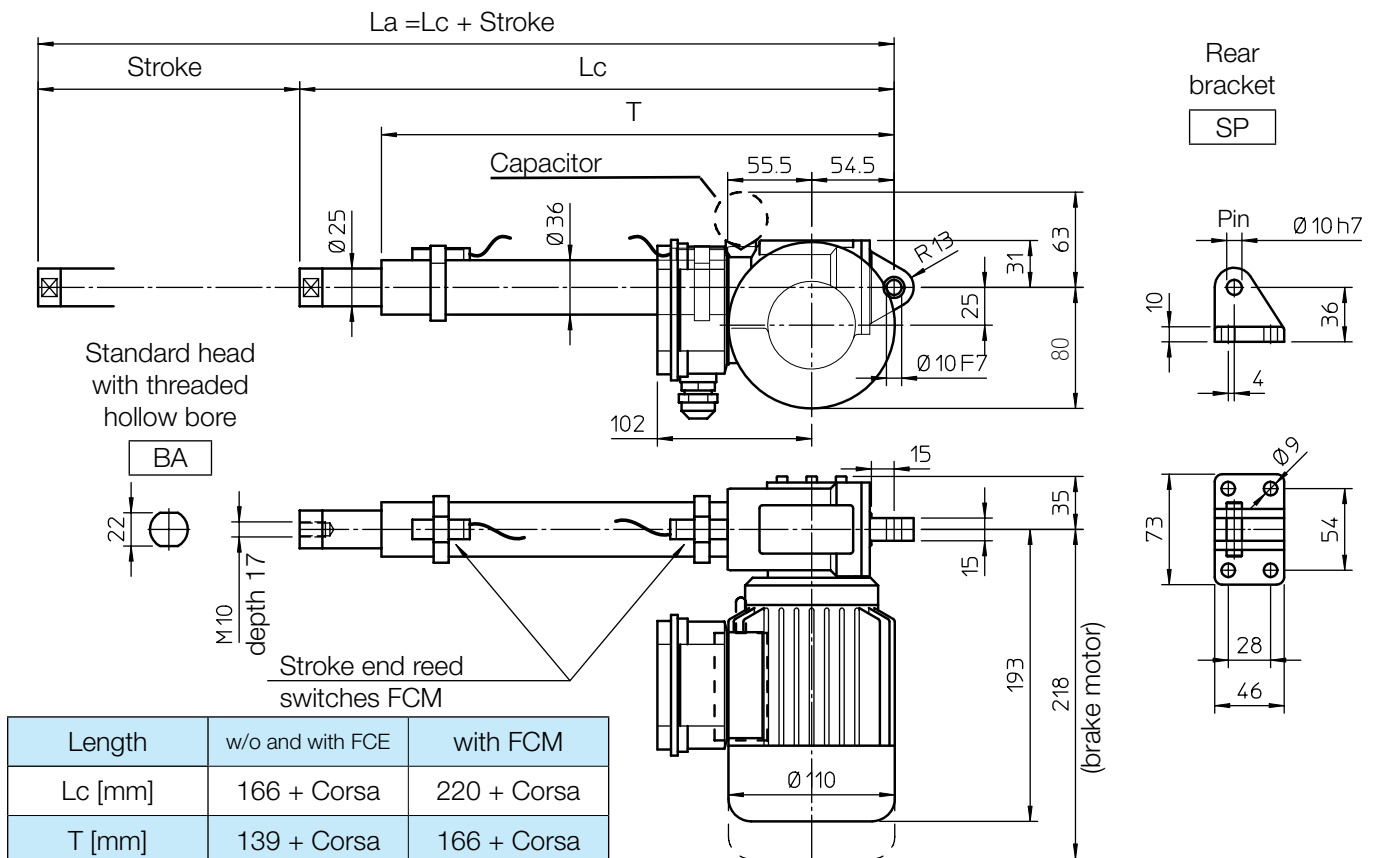

Length	w/o and with FCE	with FCM
Lc [mm]	166 + Corsa	220 + Corsa
T [mm]	139 + Corsa	166 + Corsa

STROKE CODE	C100	C150	C200	C300	C400	C500
Working stroke length w/o and with FCE [mm]	100	150	200	300	400	500
Working stroke length with FCM [mm]	73	123	173	273	373	473

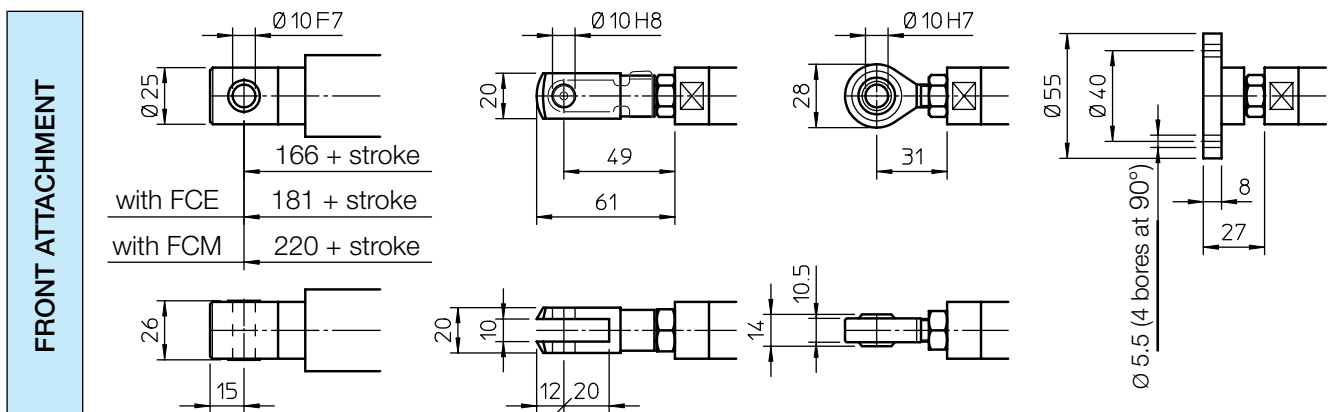
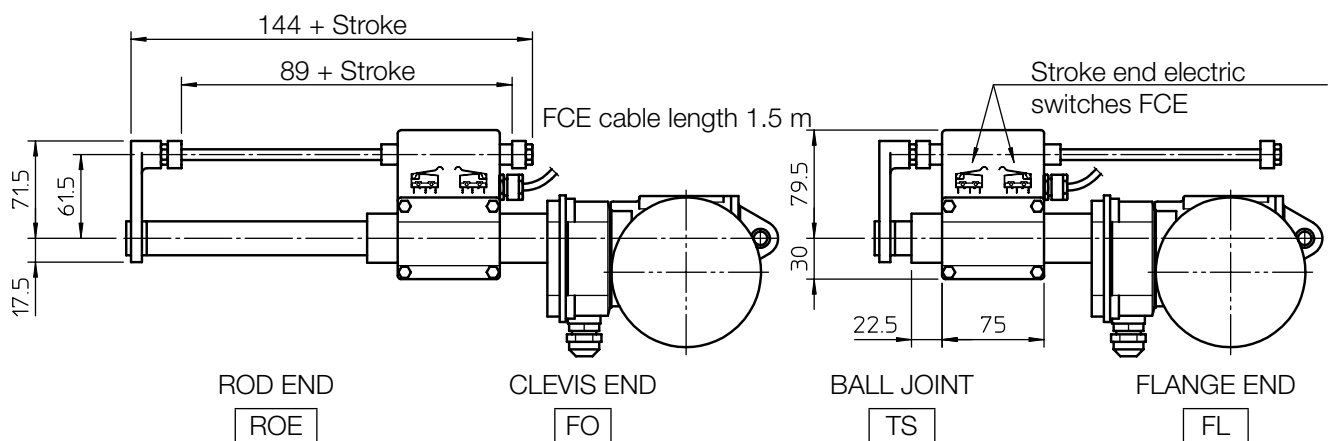



ACME SCREW LINEAR ACTUATOR ATL 10 AC motor

PERFORMANCES AND FEATURES

- Push load up to 5 000 N
- Pull load up to 4 000 N
- Linear speed up to 140 mm/s
- Standard stroke lengths: 100, 150, 200, 300, 400, 500 mm (for different / longer stroke lengths please contact us)
- Aluminium alloy housing and rear attachment, with bronze bush
- Anodized aluminium outer tube
- Chrome-plated steel push rod – tolerance f7
- Standard head BA or rod end ROE in stainless steel AISI 303 with bronze bush
- AC 3-phase or 1-phase motor (motor features details on page 70)
- Duty cycle with max load: 30% over 10 min at (-10...+40) °C
- Standard protection IP55 (IP54 with brake)
- Standard motor mounting position as per sketch (right-hand, code RH)
- Long-life lubrication, maintenance free

ACCESSORIES

- Different front attachments
- Stainless steel push rod (code SS)
- Rear bracket (code SP)
- Mechanical overload protection, safety clutch (code FS)
- Brake motor
- Two adjustable stroke end reed switches (code FCM)
- Extra switches for intermediate positions
- Electromechanical stroke end switch for linear speed up to 30 mm/s (code FCE) (technical data on page 72)

OPTIONS

- Motor mounting position on opposite side (left-hand, code LH)
- Fixing attachment turned at 90° (code RPT 90)

PERFORMANCES with AC 3-phase 50 Hz 230/400 V or 1-phase 50 Hz 230 V motor

1-start acme screw Tr 14x4				
RATIO	0.09 kW - 4 pole motor		0.12 kW - 2 pole motor	
	LOAD [N]	SPEED [mm/s]	LOAD [N]	SPEED [mm/s]
RH1	1750	23	1250	47
RV1	2620	15	1860	30
RN1	4490	7.5	3230	15
RL1	5000	3.5	5000	7.5
RXL1	5000	2	5000	3.5

2-starts acme screw Tr 14x8 (P4)				
RATIO	0.09 kW - 4 pole motor		0.12 kW - 2 pole motor	
	LOAD [N]	SPEED [mm/s]	LOAD [N]	SPEED [mm/s]
RH2	1070	47	790	93
RV2	1620	30	1180	60
RN2	2880	15	2080	30
RL2	4800	7.5	3520	15

3-starts acme screw Tr 14x12 (P4)				
RATIO	0.09 kW - 4 pole motor		0.12 kW - 2 pole motor	
	LOAD [N]	SPEED [mm/s]	LOAD [N]	SPEED [mm/s]
RH3	800	70	560	140
RV3	1210	45	860	90
RN3	2190	22	1540	45
RL3	3680	11	2680	22

Self-locking conditions

Information about statically self-locking conditions with pull or push load on page 68.

ORDERING CODE EXAMPLE

ATL 10	RL1	C200	CA 230/400 V	FCM					
Actuator	Selected ratio	Required stroke	Motor	Stroke end switches	Accessories			Options	

OVERALL DIMENSIONS

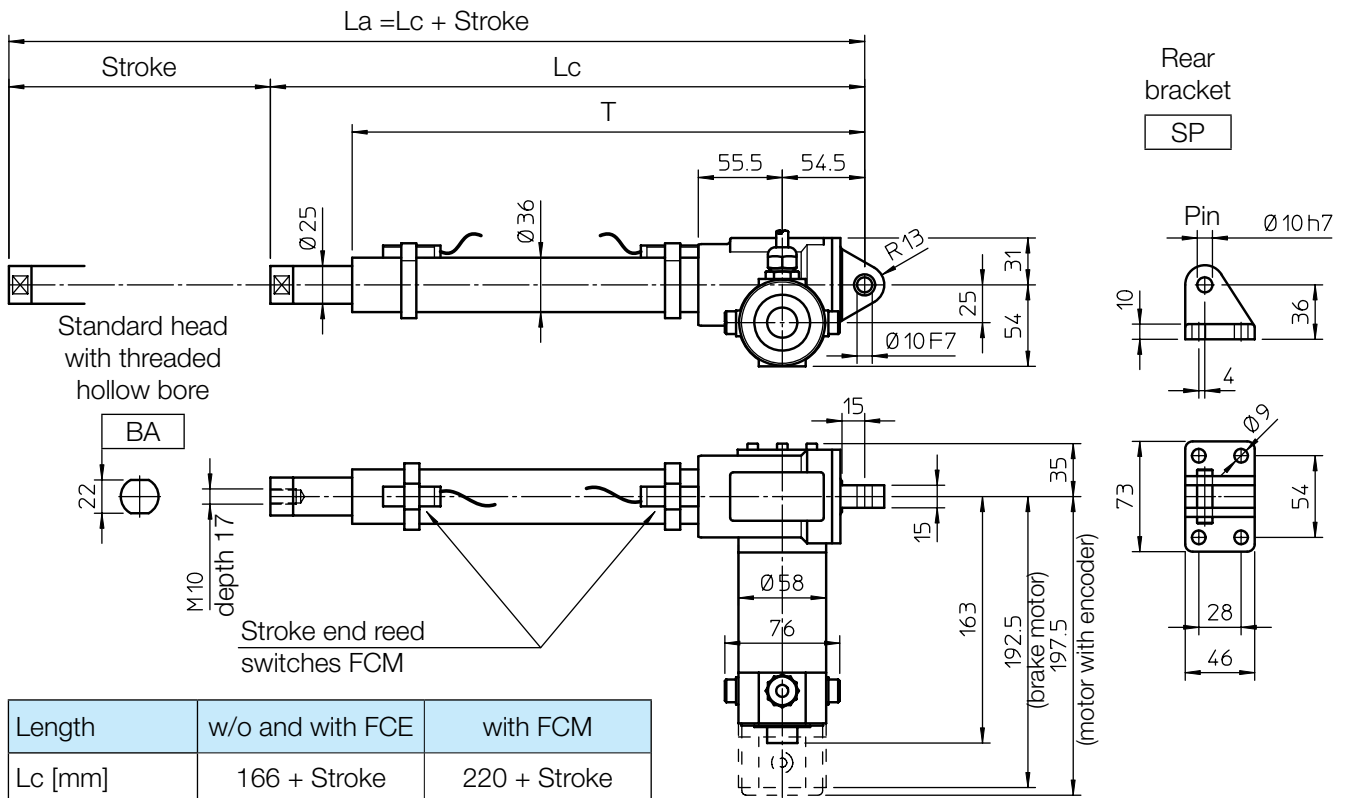

Length	w/o and with FCE	with FCM
Lc [mm]	166 + Stroke	220 + Stroke
T [mm]	139 + Stroke	166 + Stroke

STROKE CODE	C100	C150	C200	C300	C400	C500
Working stroke length w/o and with FCE [mm]	100	150	200	300	400	500
Working stroke length with FCM [mm]	73	123	173	273	373	473

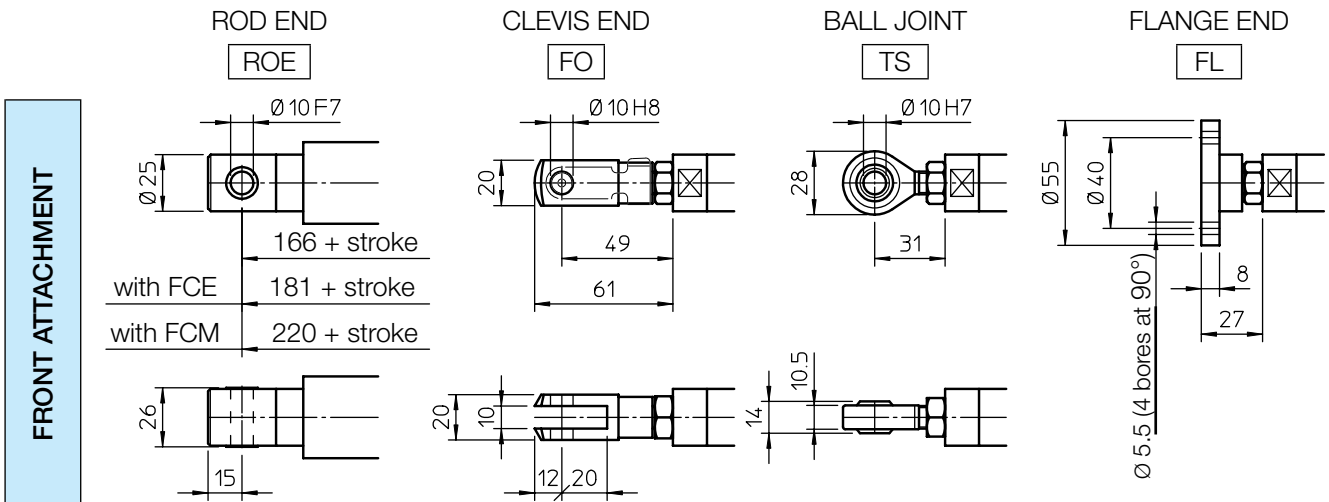
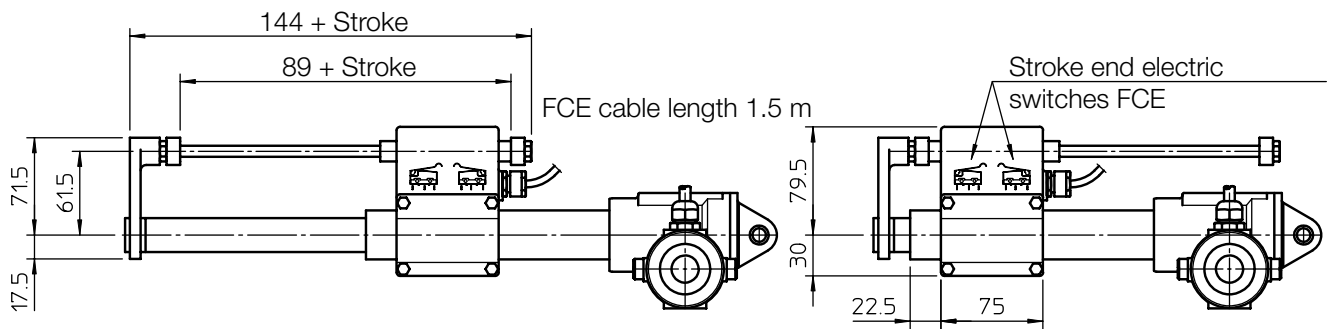



ACME SCREW LINEAR ACTUATOR ATL 10 DC motor

PERFORMANCES AND FEATURES

- Pull-Push load up to 4 000 N
- Linear speed up to 150 mm/s
- Standard stroke lengths: 100, 150, 200, 300, 400, 500 mm (for different / longer stroke lengths please contact us)
- Aluminium alloy housing and rear attachment, with bronze bush
- Anodized aluminium outer tube
- Chrome-plated steel push rod – tolerance f7
- Standard head BA or rod end ROE in stainless steel AISI 303 with bronze bush
- DC 12 or 24 V motor (motor features details on page 69)
- Duty cycle with max load: 30% over 10 min at (-10 ... +40) °C
- Standard protection IP54
- Standard motor mounting position as per sketch (right-hand, code RH)
- Long-life lubrication, maintenance free

ACCESSORIES

- Different front attachments
- Stainless steel push rod (code SS)
- Rear bracket (code SP)
- Mechanical overload protection: safety clutch (code FS)
- Brakemotor
- Bi-directional incremental encoder, 100 ppr with zero set pulse, Push-Pull, 8÷24 Vdc (code EH38)
- Two adjustable stroke end reed switches (code FCM)
- Extra switches for intermediate positions
- Electromechanical stroke end switch for linear speed up to 30 mm/s (code FCE) (technical data on page 72)

OPTIONS

- Motor mounting position on opposite side (left-hand, code LH)
- Fixing attachment turned at 90° (code RPT 90)

PERFORMANCES with 24 V DC motor

(Performances with 12 V DC motor: same load, linear speed 10 % less, electrical consumption 2 times more)

1-start acme screw Tr 14x4			
RATIO	LOAD [N]	SPEED [mm/s]	CURRENT [A]
RH1	680	50	4
RV1	1020	32	4
RN1	1770	16	4
RL1	2960	8	4
RXL1	4000	4	4

2-starts acme screw Tr 14x8 (P4)			
RATIO	LOAD [N]	SPEED [mm/s]	CURRENT [A]
RH2	430	100	4
RV2	650	64	4
RN2	1160	32	4
RL2	1970	16	4

3-starts acme screw Tr 14x12 (P4)			
RATIO	LOAD [N]	SPEED [mm/s]	CURRENT [A]
RH3	310	150	4
RV3	470	96	4
RN3	840	48	4
RL3	1430	24	4

Self-locking conditions

Information about statically self-locking conditions with pull or push load on page 68.

ORDERING CODE EXAMPLE

ATL 10	RL1	C200	CC 24 V	FCM					
Actuator	Selected ratio	Required stroke	Motor	Stroke end switches	Accessories			Options	

OVERALL DIMENSIONS

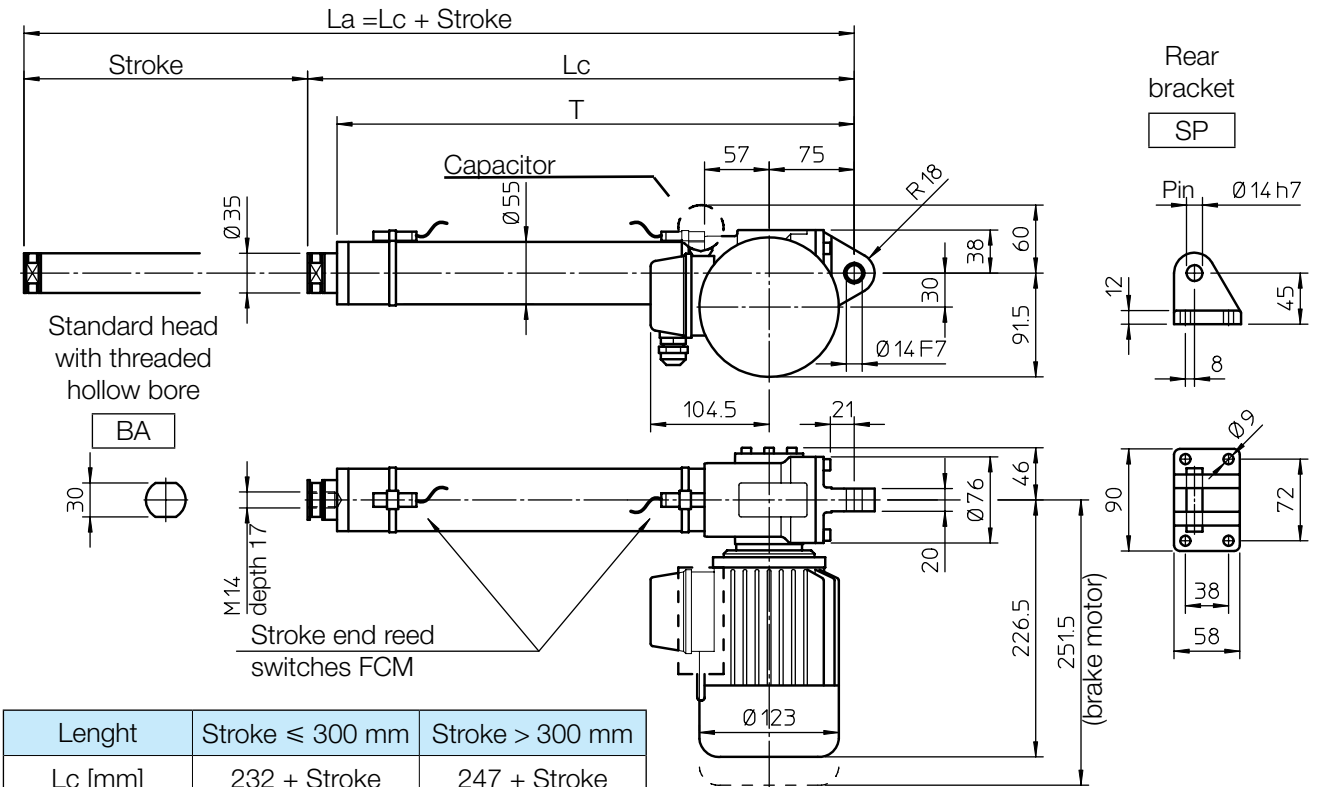

Lenght	Stroke ≤ 300 mm	Stroke > 300 mm
Lc [mm]	$232 + \text{Stroke}$	$247 + \text{Stroke}$
T [mm]	$206 + \text{Stroke}$	$206 + \text{Stroke}$
Q [mm]	252	267

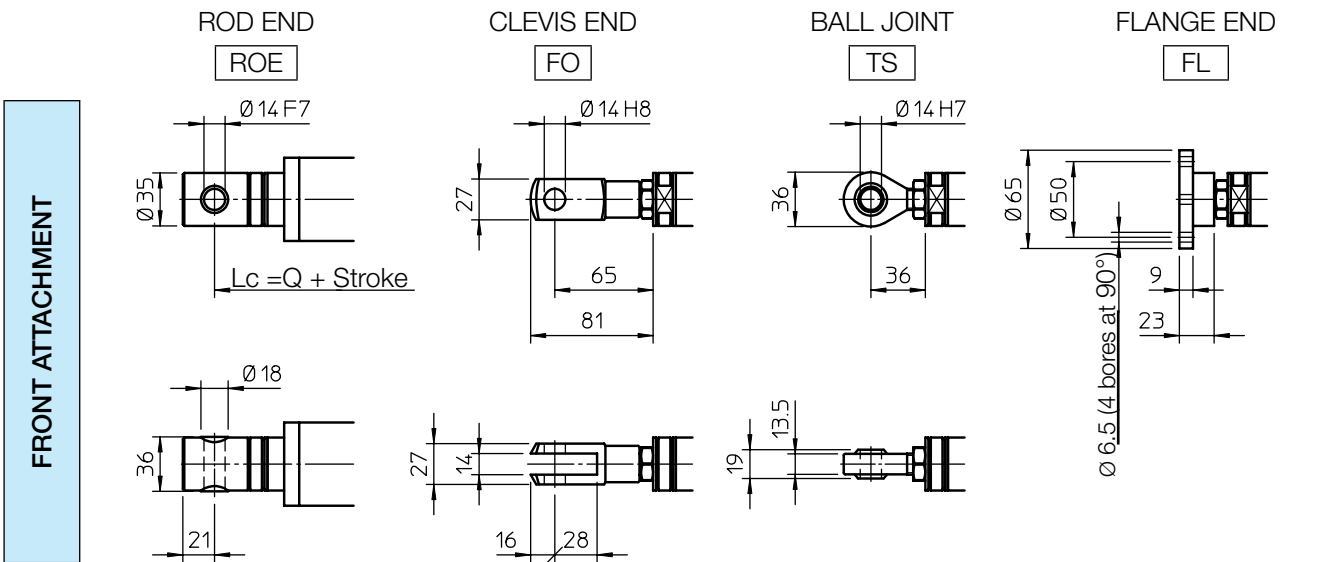
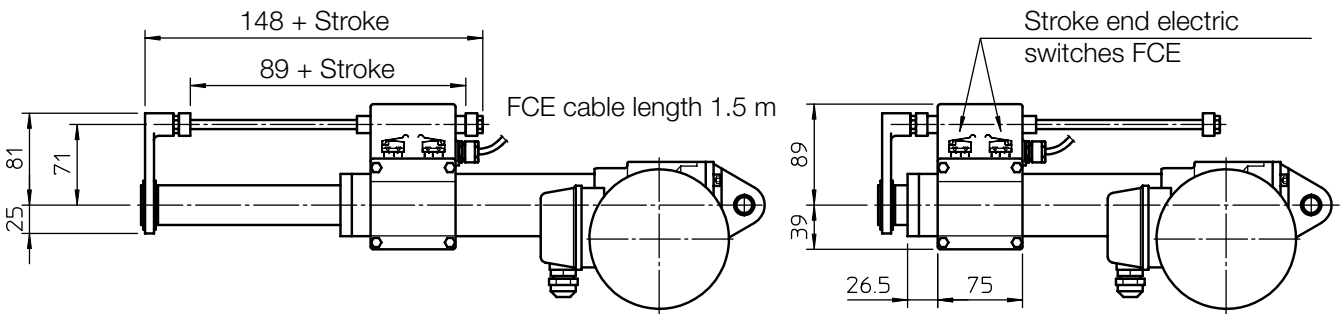

PERFORMANCES AND FEATURES

- Push load up to 11 000 N
- Pull load up to 8 000 N
- Linear speed up to 93 mm/s
- Standard stroke lengths:
100, 150, 200, 300, 400, 500, 600, 700, 800 mm
(for different /longer stroke lengths please contact us)
- Aluminium alloy housing and rear attachment,
with bronze bush
- Anodized aluminium outer tube
- Chrome-plated steel push rod – tolerance f7
- Standard front head BA or rod end ROE
in stainless steel AISI 303 with bronze bush
- AC 3-phase or 1-phase motor
(motor features on page 70)
- Standard protection IP55 (IP54 with brake)
- Duty cycle with max load:
30% over 10 min at (-10 ... +40) °C
- Standard motor mounting position as per sketch
(right-hand, code RH)
- Long-life lubrication, maintenance free

ACCESSORIES

- Different front attachments
- Stainless steel push rod (code SS)
- Rear bracket (code SP)
- Mechanical overload protection: safety clutch
(code FS)
- Brake motor
- Two adjustable stroke end reed switches
(code FCM)
- Extra switches for intermediate positions
- Electro-mechanical stroke end switch
for linear speed up to 30 mm/s
(code FCE)
(technical data on page 72)

OPTIONS

- Motor mounting position on opposite side
(left-hand, code LH)
- Fixing attachment turned at 90° (code RPT 90)

PERFORMANCES with AC 3-phase 50 Hz 230/400 V or 1-phase 50 Hz 230 V motor

1-start acme screw Tr 18x4				
RATIO	0.18 kW - 4 pole motor		0.25 kW - 2 pole motor	
	LOAD [N]	SPEED [mm/s]	LOAD [N]	SPEED [mm/s]
RV1	3130	23	2450	47
RN1	9620	5.5	7320	11
RL1	11000	2.5	11000	5.5

2-starts acme screw Tr 18x8 (P4)				
RATIO	0.18 kW - 4 pole motor		0.25 kW - 2 pole motor	
	LOAD [N]	SPEED [mm/s]	LOAD [N]	SPEED [mm/s]
RV2	2070	47	1590	93
RN2	6710	11	4500	22
RL2	10280	5.5	7660	11

Self-locking conditions

Information about statically self-locking conditions with pull or push load on page 68.

ORDERING CODE EXAMPLE

ATL 12	RL1	C200	CA 230/400 V	FCM					
Actuator	Selected ratio	Required stroke	Motor	Stroke end switches	Accessories			Options	

OVERALL DIMENSIONS

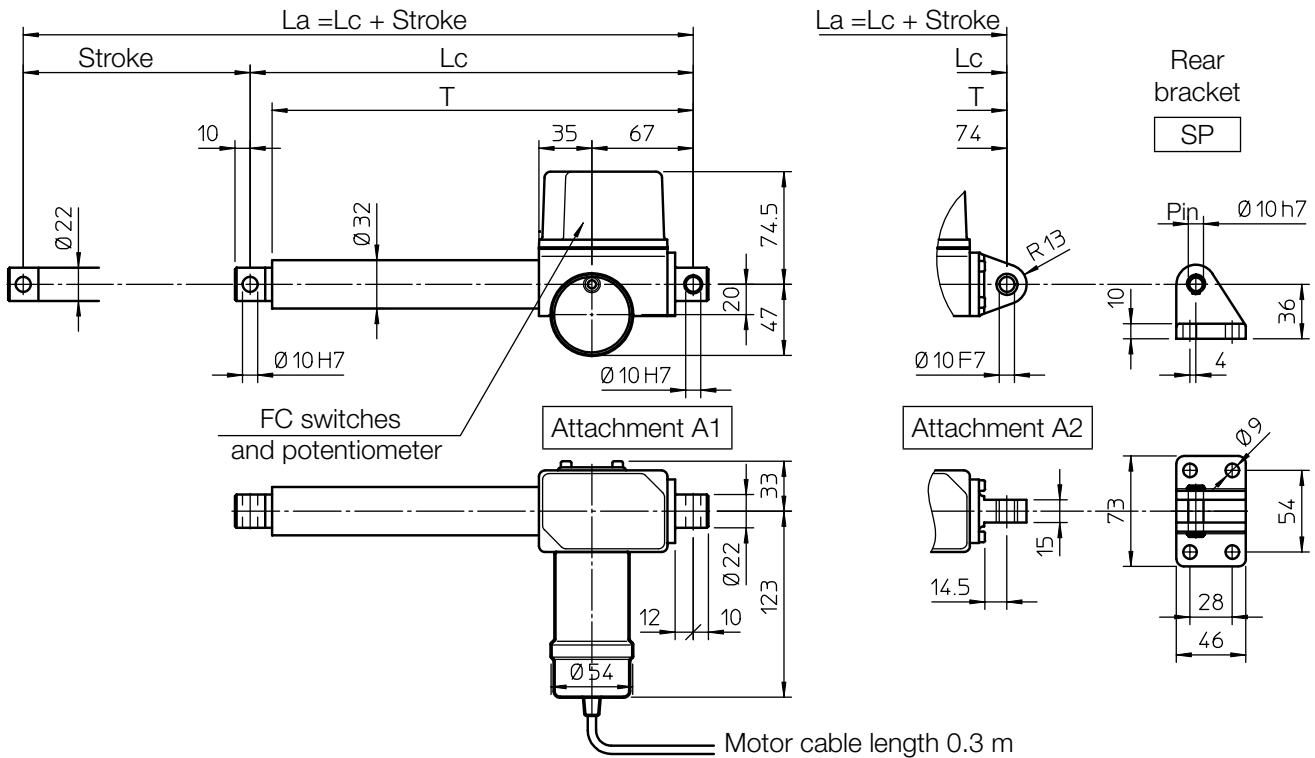

Length	Actuator with Attachment A1	Actuator with Attachment A2
Lc [mm]	142 + Stroke	150 + Stroke
T [mm]	129 + Stroke	136 + Stroke

PERFORMANCES AND FEATURES

- Pull-Push load up to 2 000 N
 - Linear speed up to 48 mm/s (DC motor)
 - Linear speed up to 30 mm/s (AC motor)
 - Standard stroke lengths: 100, 150, 200, 250, 300 mm (for different / longer stroke lengths please contact us)
 - Aluminium alloy housing and rear attachment
 - Anodized aluminium outer tube
 - Anodized aluminium push rod – tolerance h8
 - Rear attachment:
 - A1 zinc-plated steel
 - A2 aluminium alloy with bronze bush
 - Stainless steel AISI 303 front attachment
 - Motors: (motor features details on page 69 and 70)
 - 12 or 24 V DC motor with permanent magnets
 - AC 3-phase or 1-phase motor
 - Duty cycle with max load:
 - DC motor max.15% over 10 min at (-10 ... +40) °C
 - AC motor max.30% over 10 min at (-10 ... +40) °C
 - Standard protection:
 - with DC motor IP65
- Test IP6X according to EN 60529 §12 §13.4-13.6
 Test IPX5 according to EN 60529 §14.2.5 (tests made with not running actuator)
- with AC motor IP55

- Standard motor mounting position as per sketch (right-hand, code RH)
- Long-life lubrication, maintenance free

ACCESSORIES

- Stainless steel push rod (code SS)
- Rear bracket (code SP) with rear attachment A2
- Adjustable electric stroke end switches (code FC2)
- Adjustable electric stroke end switches, switching off the motor (not available with AC 3-phase motor) (code FC2X)
- Extra switch for intermediate position (code FC)
- Rotative potentiometer 5kOhm for positioning control (code POR5K)

NOTE: Extra limit switch and rotative potentiometer cannot be selected together

OPTIONS

- Motor mounting position on opposite side (left-hand, code LH)
- Fixing attachment turned at 90° (code RPT 90)

PERFORMANCES with AC 3-phase 50 Hz 230/400 V or 1-phase 50 Hz 230 V motor

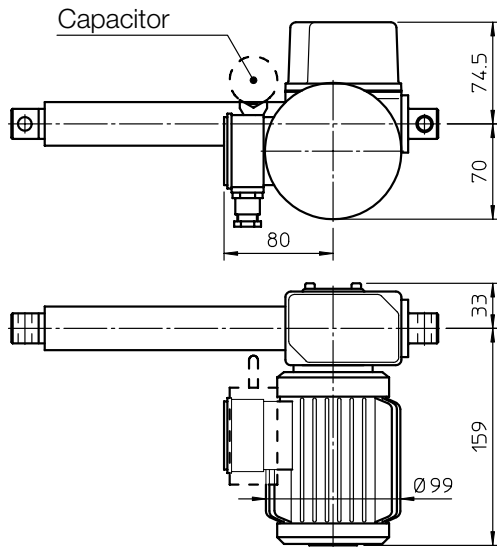

1-start acme screw Tr 13.5x3		
0.06 kW - 2 pole motor		
RATIO	LOAD [N]	SPEED [mm/s]
RN1	1500	11
RL1	2000	5.5

2-starts acme screw Tr 14x8 (P4)		
0.06 kW - 2 pole motor		
RATIO	LOAD [N]	SPEED [mm/s]
RN2	1000	30
RL2	1100	15

PERFORMANCES with 24 V DC motor

(Performances with 12 V DC motor: same load, linear speed 10 % less, electrical consumption 2 times more)

1-start acme screw Tr 13.5x3

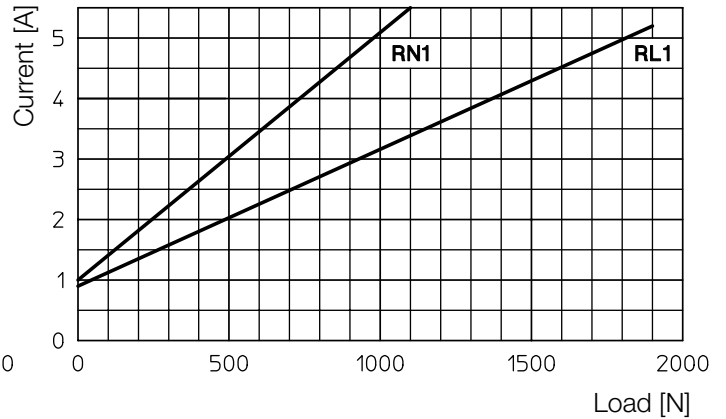
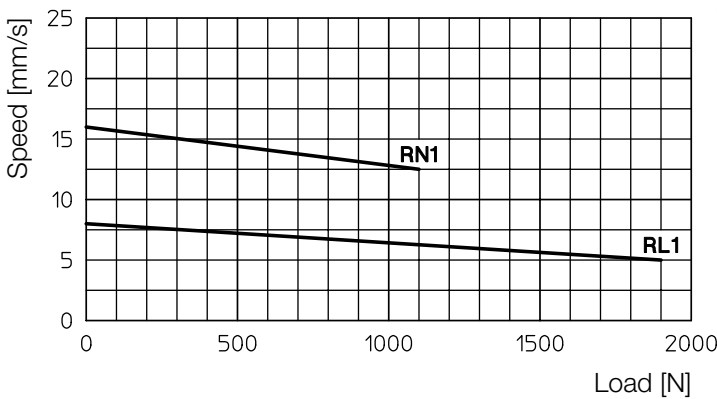

2-starts acme screw Tr 14x8 (P4)

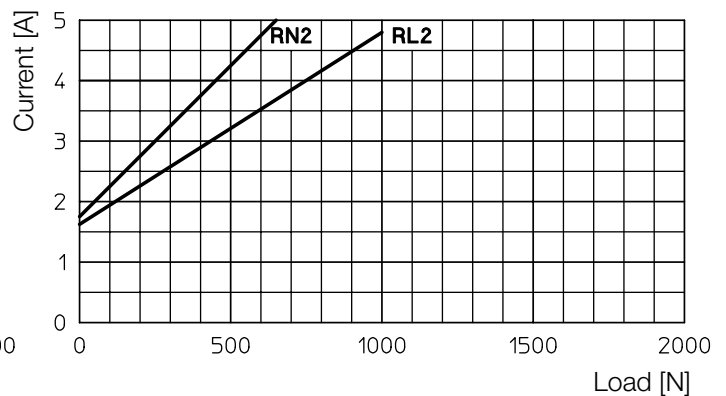
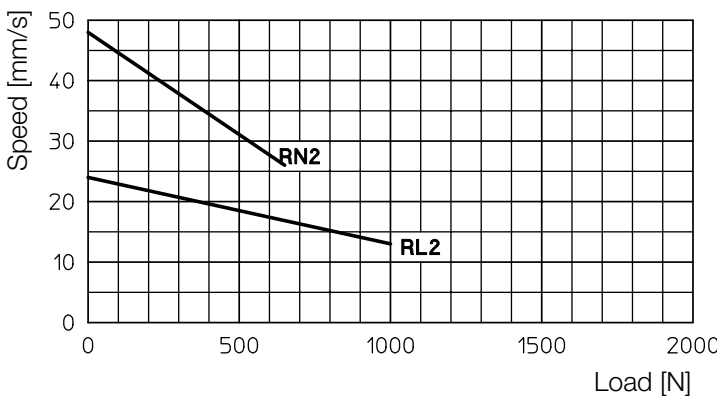

Self-locking conditions

Information about statically self-locking conditions with pull or push load on page 68.

ORDERING CODE EXAMPLE

CLA 20	RL1	C200	CC 24 V	FC2	POR 5K			
Actuator	Selected ratio	Required stroke	Motor	Stroke end switches	Accessories		Options	

OVERALL DIMENSIONS

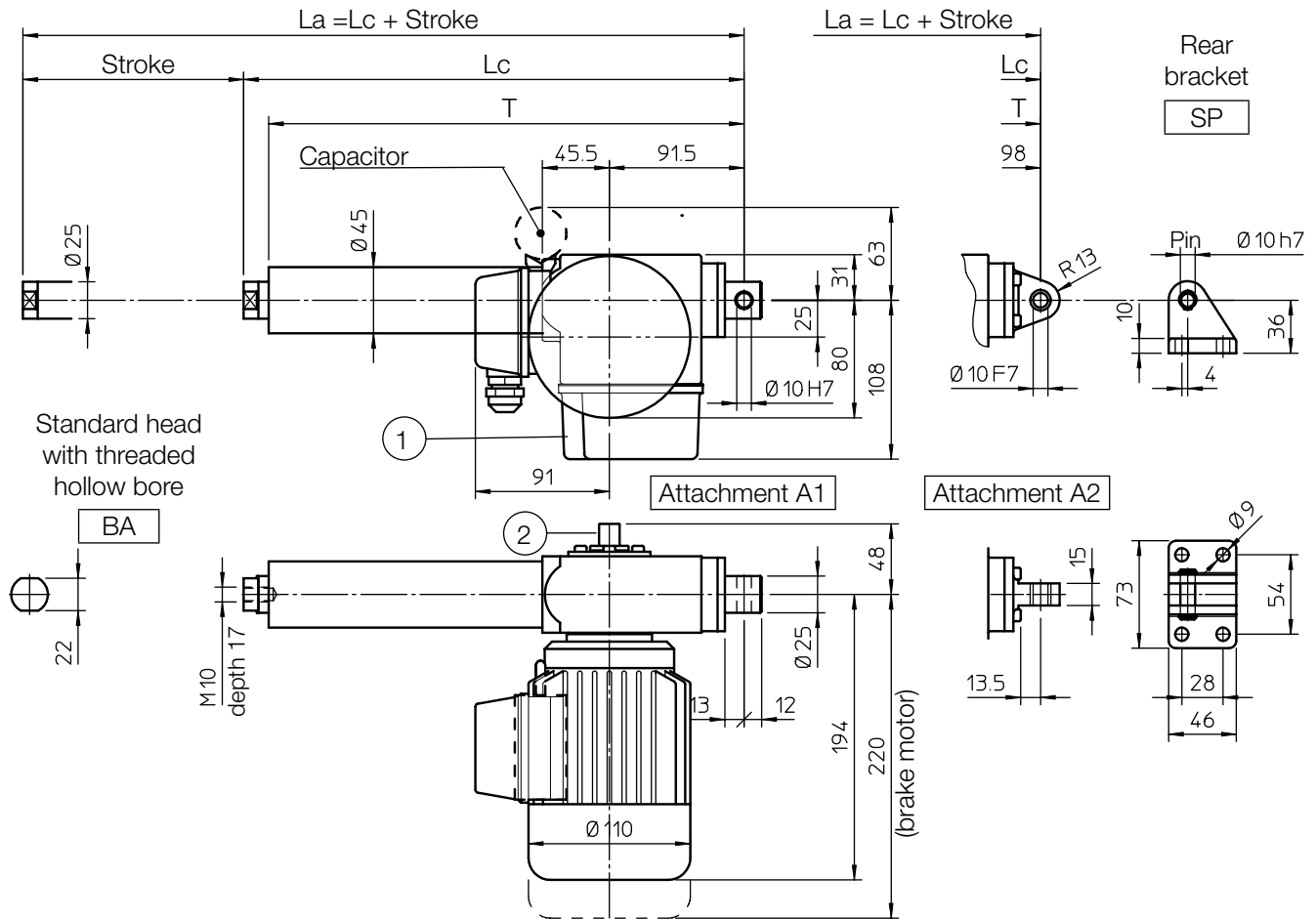

1. STROKE END SWITCHES BOX AND POTENTIOMETER
2. MOTOR SHAFT EXTENSION for:
Emergency manual activation
Stroke end switches and potentiometer adjustment

Q [mm]	Attachment A1	Attachment A2
	195	202

STROKE CODE	Actuator - Attachment A1			Actuator - Attachment A2			MASS [Kg]
	STROKE [mm]	LENGTH		STROKE [mm]	LENGTH		
		Lc [mm]	La [mm]		Lc [mm]	La [mm]	
C100	100	290	390	100	297	397	5.3
C200	200	390	590	200	397	597	5.6
C300	300	490	790	300	497	797	5.9

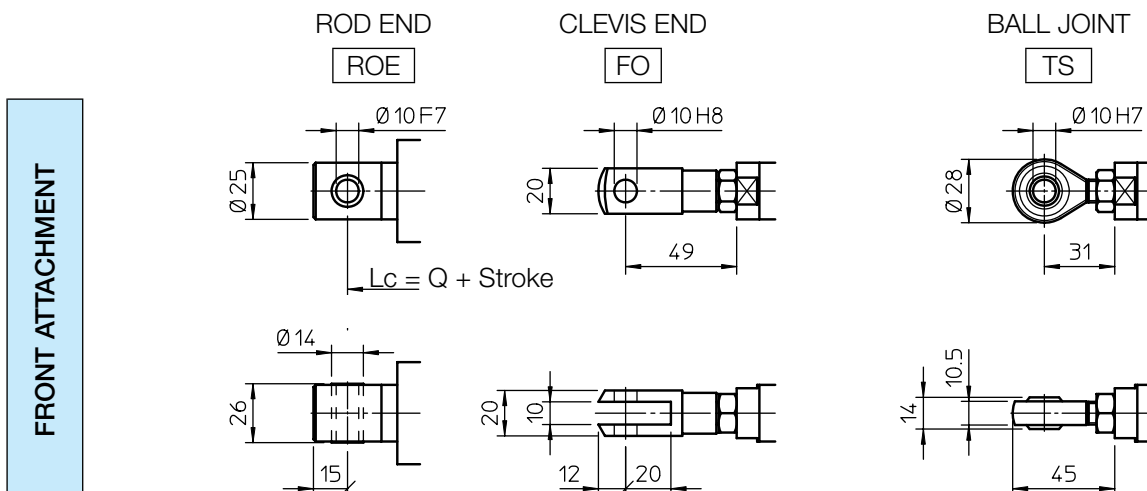



ACME SCREW LINEAR ACTUATOR CLA 25 AC motor

PERFORMANCES AND FEATURES

- Push load up to 5 000 N
- Pull load up to 4 000 N
- Linear speed up to 93 mm/s
- Standard stroke lengths: 100, 150, 200, 250, 300 mm (for different / longer stroke lengths please contact us)
- Aluminium alloy housing
- Rear attachment:
 - A1 zinc-plated steel
 - A2 aluminium alloy with bronze bush
- Anodized aluminium outer tube
- Chrome-plated steel push rod – tolerance f7
- Standard head BA or rod end ROE in stainless steel AISI 303 with bronze bush
- AC 3-phase or 1-phase motor (motor features on page 70)
- Duty cycle with max load: 30% over 10 min at (-10 ... +40) °C
- Standard protection:
 - with AC motor without brake IP55
 - with AC brake-motor IP54
- Standard motor mounting position as per sketch (right-hand, code RH)
- Long-life lubrication, maintenance free

ACCESSORIES

- Different front attachments
- Stainless steel push rod (code SS)
- Rear bracket (code SP) with rear attachment A2
- Mechanical overload protection: safety clutch (code FS)
- Brake motor
- Adjustable electric stroke end switches (code FC2)
- Adjustable electric stroke end switches, switching off the motor (not available with AC 3-phase motor) (code FC2X)
- Extra switch for intermediate position (code FC)
- Rotative potentiometer 5kOhm for positioning control (code POR5K)

NOTE: Extra limit switch and rotative potentiometer cannot be selected together

OPTIONS

- Motor mounting position on opposite side (left-hand, code LH)
- Fixing attachment turned at 90° (code RPT 90)

PERFORMANCES with AC 3-phase 50 Hz 230/400 V or 1-phase 50 Hz 230 V motor

1-start acme screw Tr 14x4				
RATIO	0.09 kW - 4 pole motor		0.12 kW - 2 pole motor	
	LOAD [N]	SPEED [mm/s]	LOAD [N]	SPEED [mm/s]
RH1	1750	23	1250	47
RV1	2620	15	1860	30
RN1	4490	7.5	3230	15
RL1	5000	3.5	5000	7.5
RXL1	5000	2	5000	3.5

2-starts acme screw Tr 14x8 (P4)				
RATIO	0.09 kW - 4 pole motor		0.12 kW - 2 pole motor	
	LOAD [N]	SPEED [mm/s]	LOAD [N]	SPEED [mm/s]
RH2	1070	47	790	93
RV2	1620	30	1180	60
RN2	2880	15	2080	30
RL2	4800	7.5	3520	15

Self-locking conditions

Information about statically self-locking conditions with pull or push load on page 68.

ORDERING CODE EXAMPLE

CLA 25	RL1	C200	CA 230/400 V	FC2	POR 5K				
Actuator	Selected ratio	Required stroke	Motor	Stroke end switches	Accessories			Options	



ACME SCREW LINEAR ACTUATOR CLA 25 DC motor

PERFORMANCES AND FEATURES

- Pull-Push load up to 4 000 N
- Linear speed up to 100 mm/s
- Standard stroke lengths:
100, 150, 200, 250, 300 mm
(for different / longer stroke lengths please contact us)
- Aluminium alloy housing
- Rear attachment:
 - A1 zinc-plated steel
 - A2 aluminium alloy with bronze bush
- Anodized aluminium outer tube
- Chrome-plated steel push rod – tolerance f7
- Standard head BA or rod end ROE in stainless steel AISI 303 with bronze bush
- 12, 24 or 36 V DC motor with electromagnetic noise suppressor (motor features details on page 69)
- Duty cycle with max load: 15% over 10 min at (-10...+40) °C
- Standard protection IP65:
Test IP6X according to EN 60529 §12 §13.4-13.6
Test IPX5 according to EN 60529 §14.2.5
(tests made with not running actuator)

- Standard motor mounting position as per sketch (right-hand, code RH)
- Long-life lubrication, maintenance free

ACCESSORIES

- Different front attachments
- Stainless steel push rod (code SS)
- Rear bracket (code SP) with rear attachment A2
- Mechanical overload protection: safety clutch (code FS)
- Adjustable electric stroke end switches (code FC2)
- Adjustable electric stroke end switches, switching off the motor (code FC2X) (not available with AC 3-phase motor)
- Extra switch for intermediate position (code FC)
- Rotative potentiometer 5kOhm for positioning control (code POR5K)

NOTE: Extra limit switch and rotative potentiometer cannot be selected together

OPTIONS

- Motor mounting position on opposite side (left-hand, code LH)
- Fixing attachment turned at 90° (code RPT 90)

PERFORMANCES with 24 V DC motor

(Performances with 12 V DC motor: same load, linear speed 10 % less, electrical consumption 2 times more)

1-start acme screw Tr 14x4

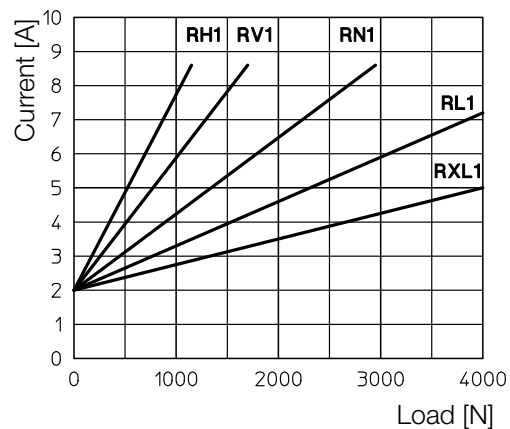
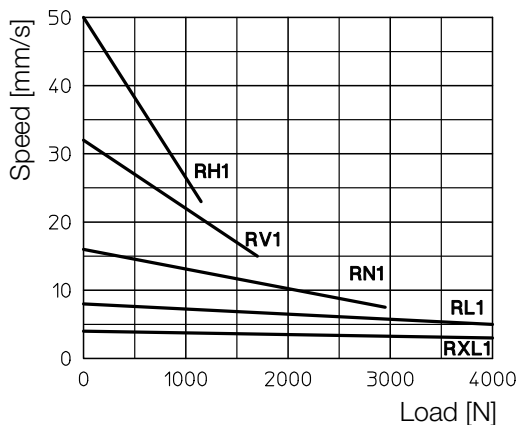

2-starts acme screw Tr 14x8 (P4)

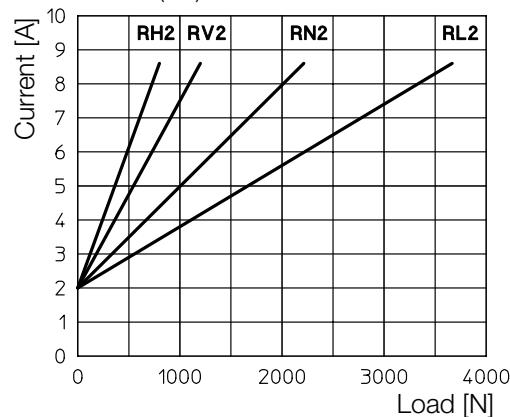
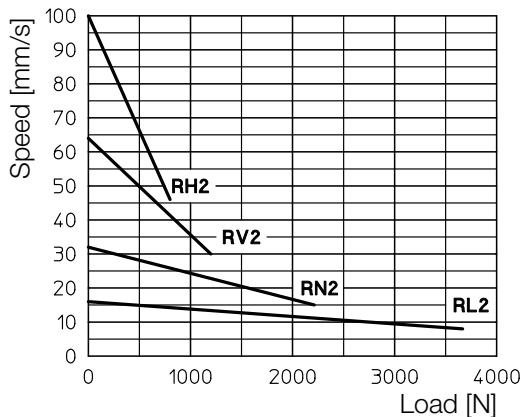

ORDERING CODE EXAMPLE

CLA 25	RL1	C200	CC 24 V	FC2	POR 5K			
Actuator	Selected ratio	Required stroke	Motor	Stroke end switches	Accessories			Options

OVERALL DIMENSIONS

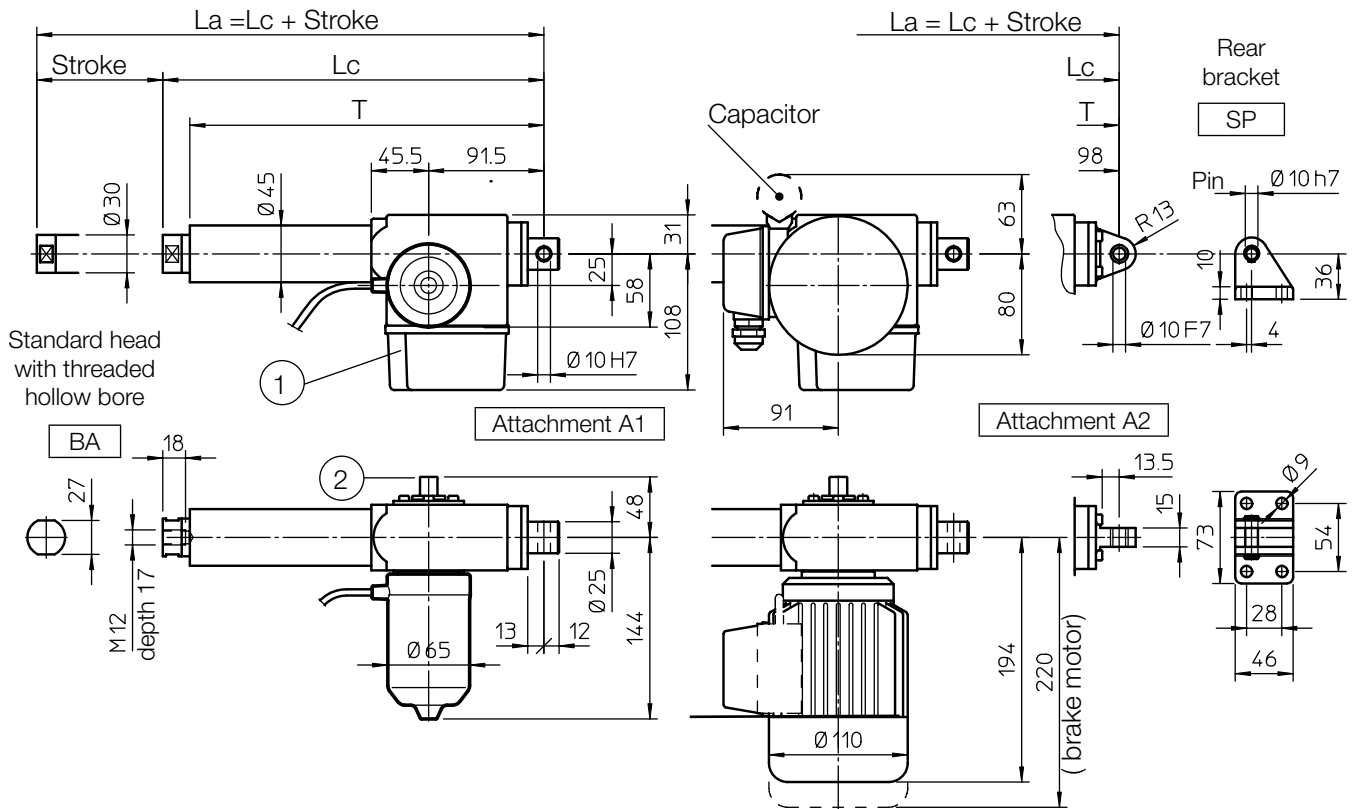

1. STROKE END SWITCHES BOX AND POTENTIOMETER
2. MOTOR SHAFT EXTENSION for:
 - Emergency manual activation
 - Stroke end switches and potentiometer adjustment

Q [mm]	Attachment A1	Attachment A2
	220	227

STROKE CODE	Actuator - Attachment A1			Actuator - Attachment A2			MASS [Kg] DC motor	MASS [Kg] AC motor		
	STROKE [mm]	LENGTH		T [mm]	STROKE [mm]	LENGTH			T [mm]	
		Lc [mm]	La [mm]			Lc [mm]	La [mm]			
C300	300	516	816	481	300	523	823	488	4.8	6.0
C400	400	616	1016	581	400	623	1023	588	5.1	6.3
C500	500	716	1216	681	500	723	1223	688	5.4	6.6
C600	600	816	1416	781	600	823	1423	788	5.7	6.9
C700	700	916	1616	881	700	923	1623	888	6.0	7.2
C800	800	1016	1816	981	800	1023	1823	988	6.3	7.5

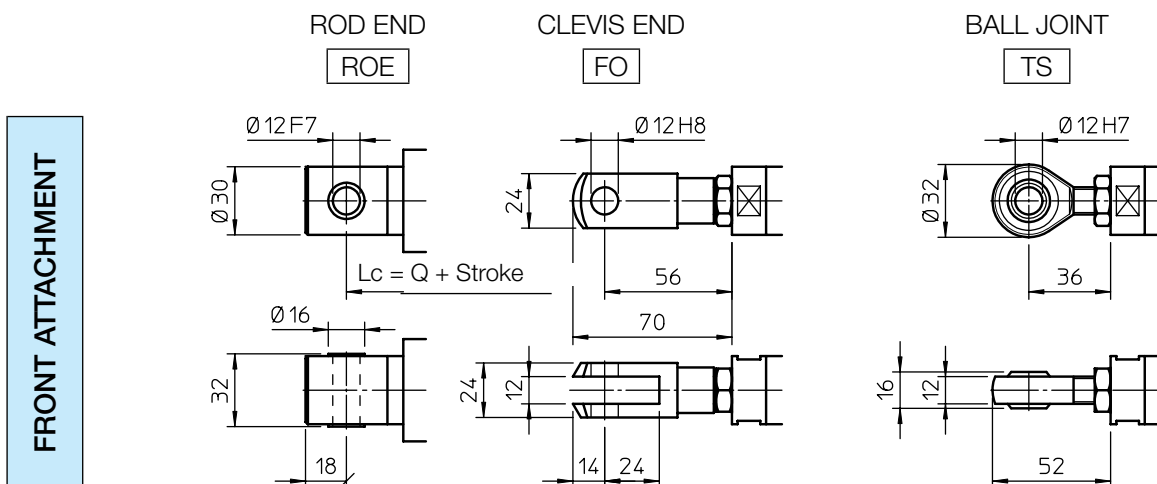

CLA 25 S and **CLA 25 M** are reinforced versions of CLA 25 linear actuator, with stronger linear drive part to improve push load resistance in case of long stroke lengths. For tables and performances graphs with the available ratios please refer to CLA 25 linear actuator.

Furthermore, compared to CLA 25 actuator, the anti-turn device (AR) is here available.

Buckling push load diagram

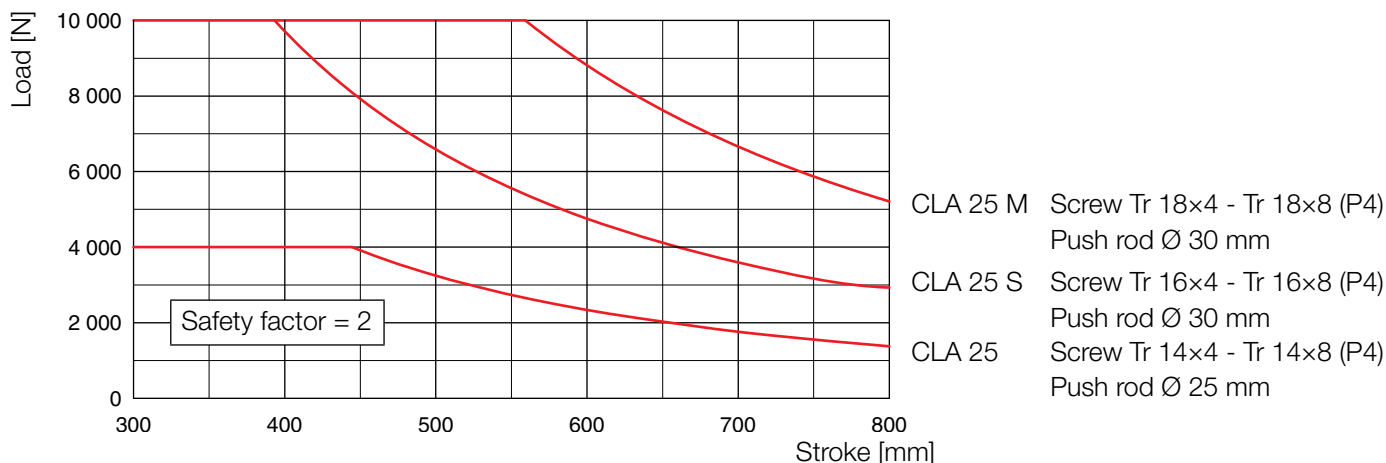

PERFORMANCES AND FEATURES

- Pull-Push load up to 5 000 N
- Linear speed up to 100 mm/s (DC motor)
Linear speed up to 90 mm/s (AC motor)
- Standard stroke lengths:
300, 400, 500, 600, 700, 800 mm
(for different / longer stroke lengths please contact us)
- Aluminium alloy housing
- Rear attachment:
 - A1 zinc-plated steel
 - A2 aluminium alloy with bronze bush
- Anodized aluminium outer tube
- Chrome-plated steel push rod – tolerance f7
- Standard head BA or rod end ROE
stainless steel AISI 303 with bronze bush
- Motors:
 - 12, 24 or 36 V DC motor
with electromagnetic noise suppressor
 - AC 3-phase or 1-phase motor
(motor features details on page 69, 70)
- Duty cycle with max load:
DC motor max 15% over 10 min at (-10 ... +40) °C
AC motor max 30% over 10 min at (-10 ... +40) °C
- Standard protection:
 - with DC motor IP65
Test IP6X according to EN 60529 §12 §13.4-13.6
Test IPX5 according to EN 60529 §14.2.5
(tests made with not running actuator)
 - with AC motor without brake IP55
 - with AC brake-motor IP54

- Standard motor mounting position as per sketch
(right-hand, code RH)
- Long-life lubrication, maintenance free

ACCESSORIES

- Different front attachments
- Stainless steel push rod (code SS)
- Rear bracket (code SP)
with rear attachment A2
- Mechanical overload protection:
safety clutch (code FS)
- AC 1-phase or 3-phase brakemotor
- Anti-turn device (code AR)
- Adjustable electric stroke end switches (code FC2)
- Adjustable electric stroke end switches,
switching off the motor (code FC2X)
(not available with AC 3-phase motor)
- Extra switch for intermediate position (code FC)
- Rotative potentiometer 5kOhm for positioning control
(code POR5K)

NOTE: Extra limit switch and rotative potentiometer cannot be selected together

OPTIONS

- Motor mounting position on opposite side
(left-hand, code LH)
- Fixing attachment turned at 90°
(code RPT 90)

Self-locking conditions

Information about statically self-locking conditions with pull or push load on page 68.

ORDERING CODE EXAMPLE

CLA 25 S	RL1	C300	CC 24 V	FC2	POR 5K				
Actuator	Selected ratio	Required stroke	Motor	Stroke end switches	Accessories			Options	

OVERALL DIMENSIONS

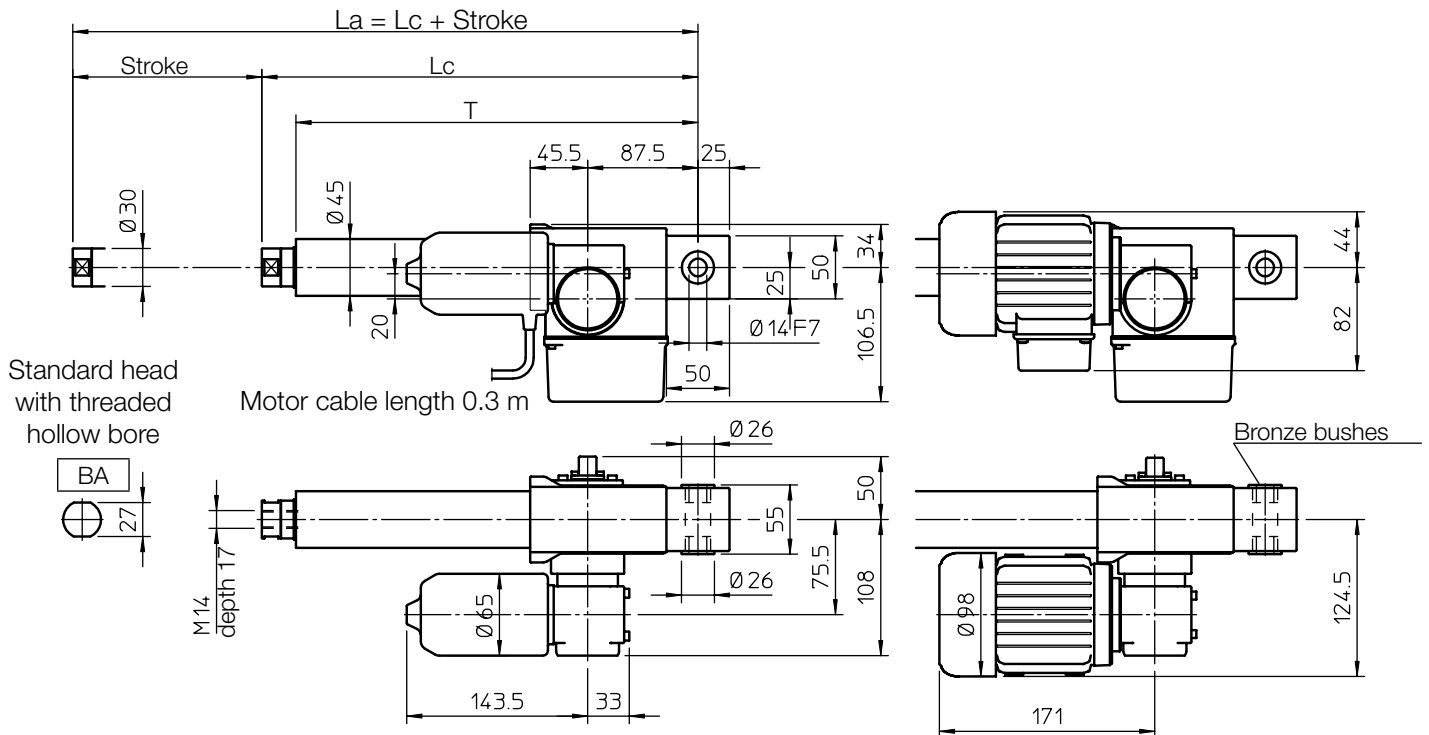

Length [mm]	
Lc [mm]	230 + Stroke
T [mm]	191 + Stroke

PERFORMANCES AND FEATURES

- Pull-Push load up to 10 000 N
- Linear speed up to 8 mm/s (DC motor)
- Linear speed up 3,7 mm/s (AC motor)
- Standard stroke lengths: 200, 300, 400, 500, 600, 700, 800 mm (for different / longer stroke lengths please contact us)
- Cast iron housing with integral rear attachment and bronze bush
- Anodized aluminium outer tube
- Chrome-plated steel push rod – tolerance f7
- Stainless steel AISI 303 front attachment BA
- Motors:
 - 12, 24 or 36 V DC motor with electromagnetic noise suppressor
 - AC 3-phase or 1-phase motor (motor features details on pages 69 and 70)
- Duty cycle with max load:
 - DC motor max 15% over 10 min at (-10 ... +40) °C
 - AC motor max 30% over 10 min at (-10 ... +40) °C
- Standard protection:
 - with DC motor IP65
 - Test IP6X according to EN 60529 §12 §13.4-13.6
 - Test IPX5 according to EN 60529 §14.2.5 (tests made with not running actuator)
 - with AC motor without brake IP55
 - with AC brake-motor IP54

- Standard motor and first stage gearbox unit mounting position as per sketch (right-hand, code RH)
- Long-life lubrication, maintenance free

ACCESSORIES

- Different front attachments
- Stainless steel push rod (code SS)
- Mechanical overload protection: safety clutch (code FS)
- Anti-turn device (code AR)
- Adjustable electric stroke end switches (code FC2)
- Adjustable electric stroke end switches, switching off the motor (not available with AC 3-phase motor) (code FC2X)
- Extra switch for intermediate position (code FC)
- Rotative potentiometer 5kOhm for positioning control (code POR5K)

NOTE: Extra limit switch and rotative potentiometer cannot be selected together

OPTIONS

- Motor and first stage gearbox unit mounting position on opposite side (left-hand, code LH)

FRONT ATTACHMENT

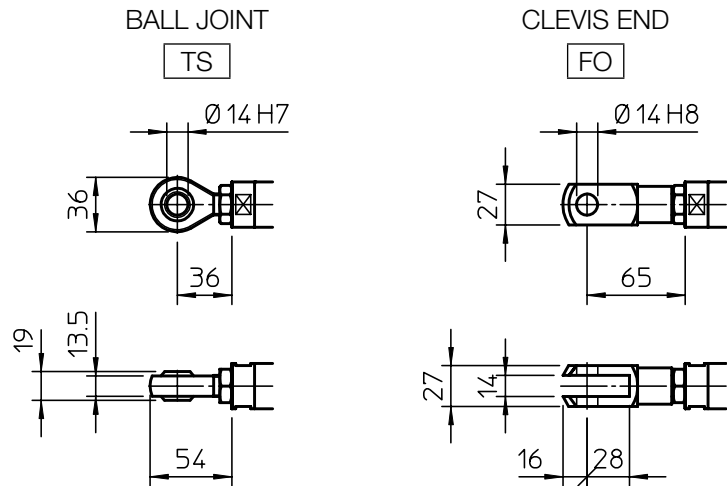

PERFORMANCES with 24 V DC motor

(Performances with 12 V DC motor: same load, linear speed 10 % less, electrical consumption 2 times more)

2-starts acme screw Tr 18x8 (P4)

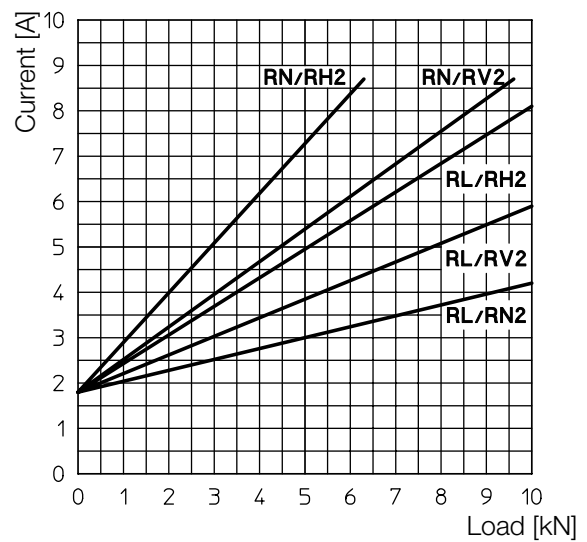
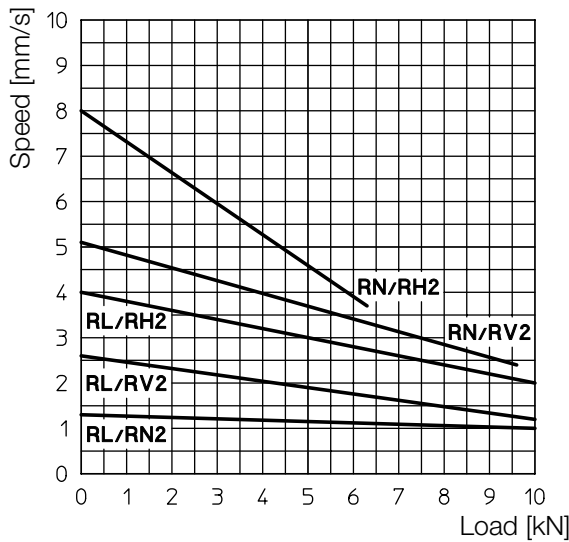

PERFORMANCES with AC 3-phase 50 Hz 230/400 V or 1-phase 50 Hz 230 V motor

2-starts acme screw Tr 18x8 (P4)		
RATIO	0.06 kW - 2 pole motor	
	LOAD [N]	SPEED [mm/s]
RL/RH2	3600	3.7
RL/RV2	5500	2.4
RL/RN2	9600	1.2

Self-locking conditions

Information about statically self-locking conditions with pull or push load on page 68.

ORDERING CODE EXAMPLE

CLA 28	RL1	C800	CC 24 V	FC2	POR 5K				
Actuator	Selected ratio	Required stroke	Motor	Stroke end switches	Accessories			Options	

CLA 28 T linear actuator differs from CLA 28 on the protective tube execution, which is made of zinc-plated steel, ext. Ø 50 mm, allowing the fitting of a bracket with self-lubricating bushes on protective tube itself.

The actuator can be hinged on these bushes, reducing by this way the attachments centre distance and improving the total resistance against push load buckling.

A typical application is lifting motion on solar trackers.

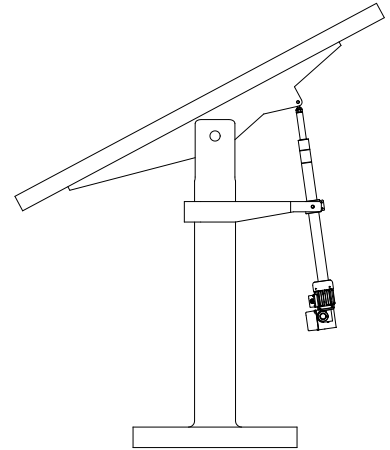

OVERALL DIMENSIONS

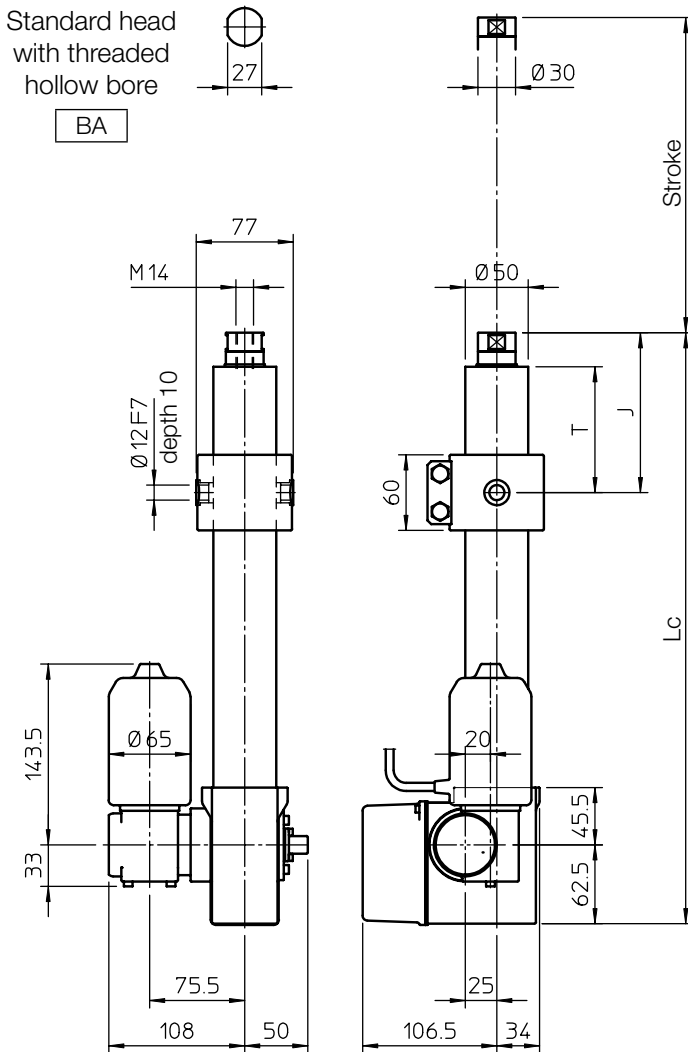

FRONT ATTACHMENT

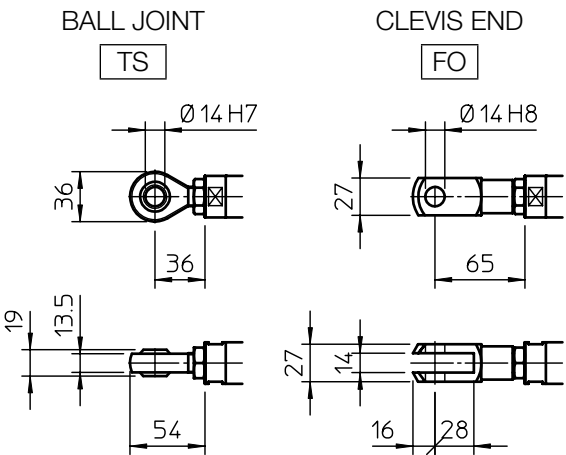

Length [mm]	
Lc	178 + Stroke
J	on customer's demand

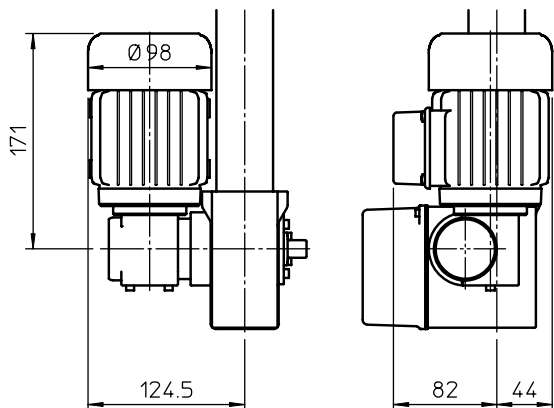

T dimension is on customer's demand according to the following formula:

$$120 \leq T \leq \frac{\text{Stroke}}{2}$$

PERFORMANCES AND FEATURES

- Pull-Push load up to 10 000 N
- Linear speed up to 8 mm/s (DC motor)
- Linear speed up to 3,7 mm/s (AC motor)
- Standard stroke lengths:
400, 500, 600, 700, 800, 900, 1 000 mm
(for different / longer stroke lengths please contact us)
- Cast iron housing with integral rear attachment
- Zinc-plated steel hinge on outer tube with self-lubricating bushes
- Zinc-plated steel outer tube with increased thickness
- Chrome-plated steel push rod – tolerance f7
- Stainless steel AISI 303 front attachment
- Motors:
 - 12, 24 or 36 V DC motor with electromagnetic noise suppressor
 - AC 3-phase or 1-phase motor (motor features details on pages 69, 70)
- Duty cycle with max load:
DC motor max 15% over 10 min at (-10 ... +40) °C
AC motor max 30% over 10 min at (-10 ... +40) °C
- Standard protection:
with DC motor IP65
- Test IP6X according to EN 60529 §12 §13.4-13.6
- Test IPX5 according to EN 60529 §14.2.5 (tests made with not running actuator)
with AC motor without brake IP55
with AC brake-motor IP54

- Standard motor and first stage gearbox unit mounting position as per sketch (right-hand, code RH)
- Long-life lubrication, maintenance free

ACCESSORIES

- Different front attachments
- Stainless steel push rod (code SS)
- Anti-turn device (code AR)
- Adjustable electric stroke end switches (code FC2)
- Adjustable electric stroke end switches, switching off the motor (code FC2X) (not available with AC 3-phase motor)
- Extra switch for intermediate position (code FC)
- Rotative potentiometer 5kOhm for positioning control (code POR5K)

NOTE: Extra limit switch and rotative potentiometer cannot be selected together

OPTIONS

- Motor and first stage gearbox unit mounting position on opposite side (left-hand, code LH)
- Fixing attachment turned at 90° (code RPT 90)

Self-locking conditions

Information about statically self-locking conditions with pull or push load on page 68.

PERFORMANCES with 24 V DC motor 2-starts acme screw Tr 18x8 (P4)

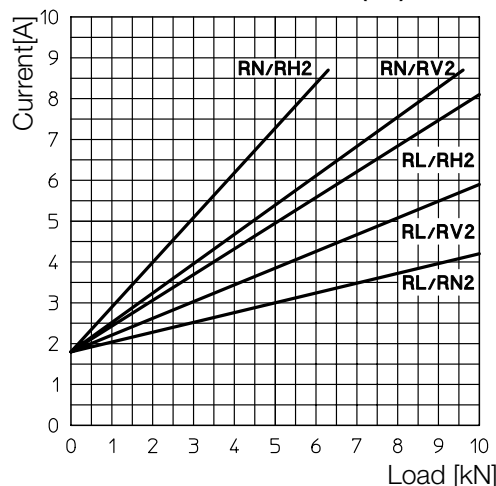
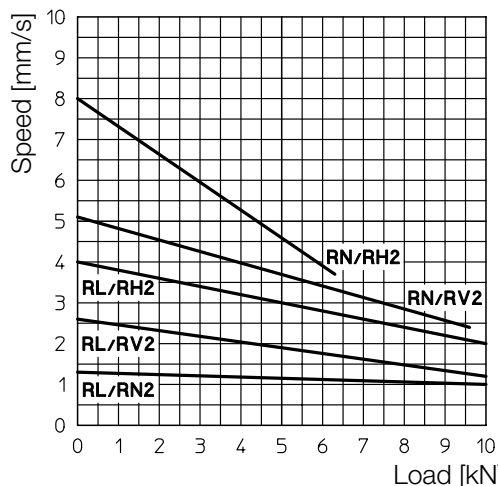

PERFORMANCES with AC 3-phase 50 Hz 230/400 V or 1-phase 50 Hz 230 V motor

2-starts acme screw Tr 18x8 (P4)		
0.06 kW - 2 pole motor		
RATIO	LOAD [N]	SPEED [mm/s]
RL/RH2	3600	3.7
RL/RV2	5500	2.4
RL/RN2	9600	1.2

ORDERING CODE EXAMPLE

CLA 28 T	RL1	C800	CC 24 V	FC2	POR 5K			
Actuator	Selected ratio	Required stroke	Motor	Stroke end switches	Accessories			Options

OVERALL DIMENSIONS

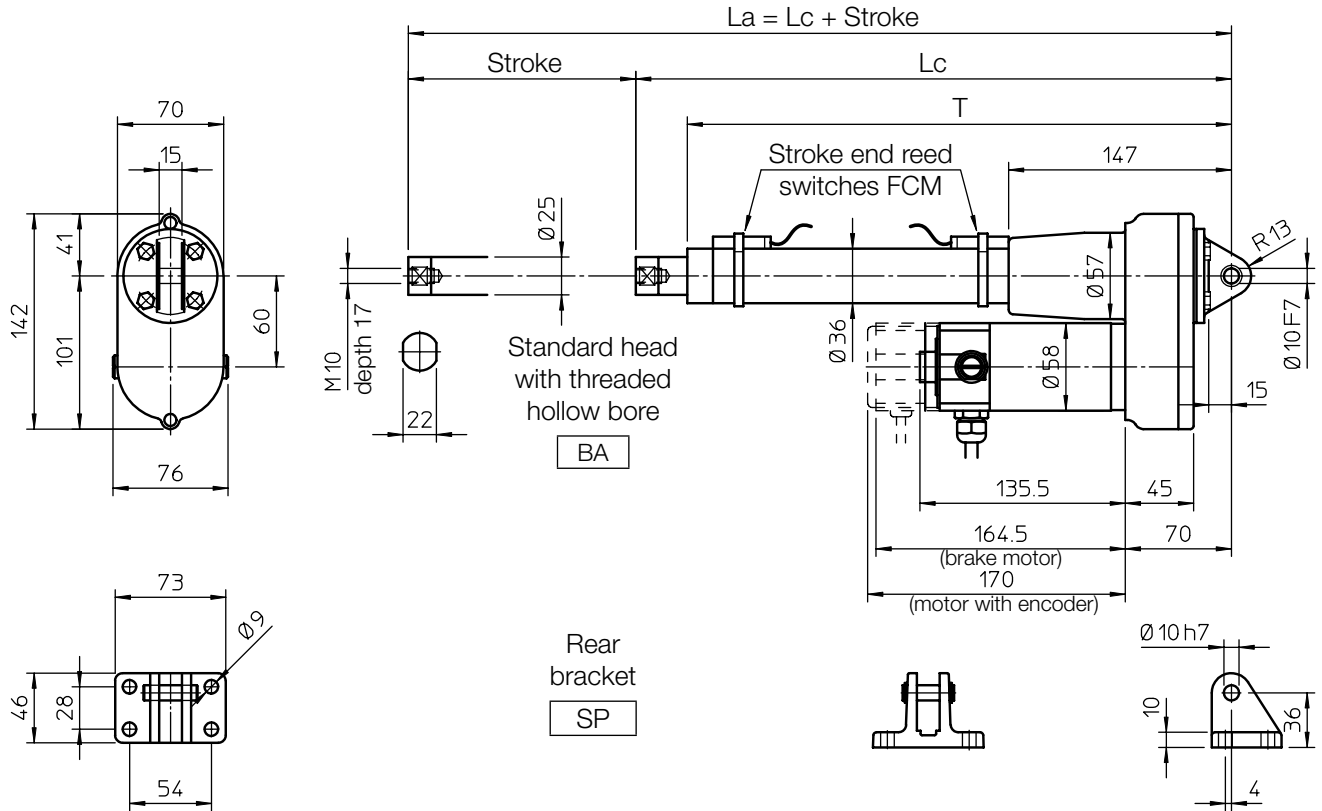

STROKE CODE	STROKE [mm]	LENGTH		T [mm]	MASS standard motor [kg]	MASS brake motor [kg]
		Lc [mm]	La [mm]			
C100	100	343	443	309	3.5	4.0
C200	200	443	643	409	3.8	4.3
C300	300	543	843	509	4.1	4.6
C400	400	643	1043	609	4.4	4.9
C500	500	743	1243	709	4.7	5.2

FRONT ATTACHMENT

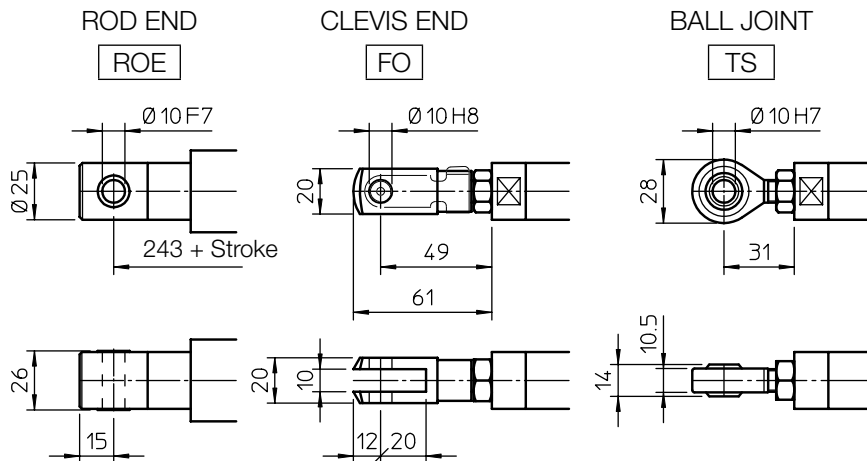

PERFORMANCES AND FEATURES

- Pull-Push load up to 400 N
- Linear speed up to 600 mm/s
- Standard stroke lengths: 100, 200, 300, 400, 500 mm (for different / longer stroke lengths please contact us)
- Aluminium alloy housing and rear attachment with bronze bush
- Anodized aluminium outer tube
- Chrome-plated push rod – tolerance f7
- Standard head BA or rod end ROE in stainless steel AISI 303 with bronze bush
- 12 or 24 V DC motor (motor features details on page 69)
- Duty cycle with max load: 30% over 10 min at (-10 ... +40) °C
- Standard protection IP 54
- Long-life lubrication, maintenance free

ACCESSORIES

- Different front attachments
- Stainless steel push rod (code SS)
- Rear bracket (code SP)
- Brake motor
- Two adjustable stroke end reed switches (code FCM)
- Extra switch for intermediate position
- Bi-directional incremental encoder, 100 ppr with zero set pulse, Push-Pull, 8÷24 Vcc (code EH38) (encoder features details on page 75)

OPTIONS

- Fixing attachment turned at 90° (code RPT 90)

PERFORMANCES with 24 V DC motor

(Performances with 12 V DC motor: same load, linear speed 10 % less, electrical consumption 2 times more)

1-start acme screw Tr 14×4			
RATIO	LOAD [N]	SPEED [mm/s]	CURRENT [A]
RV1	210	200	4
RN1	390	100	4

2-starts acme screw Tr 14×8 (P4)			
RATIO	LOAD [N]	SPEED [mm/s]	CURRENT [A]
RV2	120	400	4
RN2	230	200	4

3-starts acme screw Tr 14×12 (P4)			
RATIO	LOAD [N]	SPEED [mm/s]	CURRENT [A]
RV3	90	600	4
RN3	170	300	4

Self-locking conditions

Information about statically self-locking conditions with pull or push load on page 68.

ORDERING CODE EXAMPLE

UAL 0	RL1	C200	CC 24 V	FCM					
Actuator	Selected ratio	Required stroke	Motor	Stroke end switches	Accessories			Options	

OVERALL DIMENSIONS

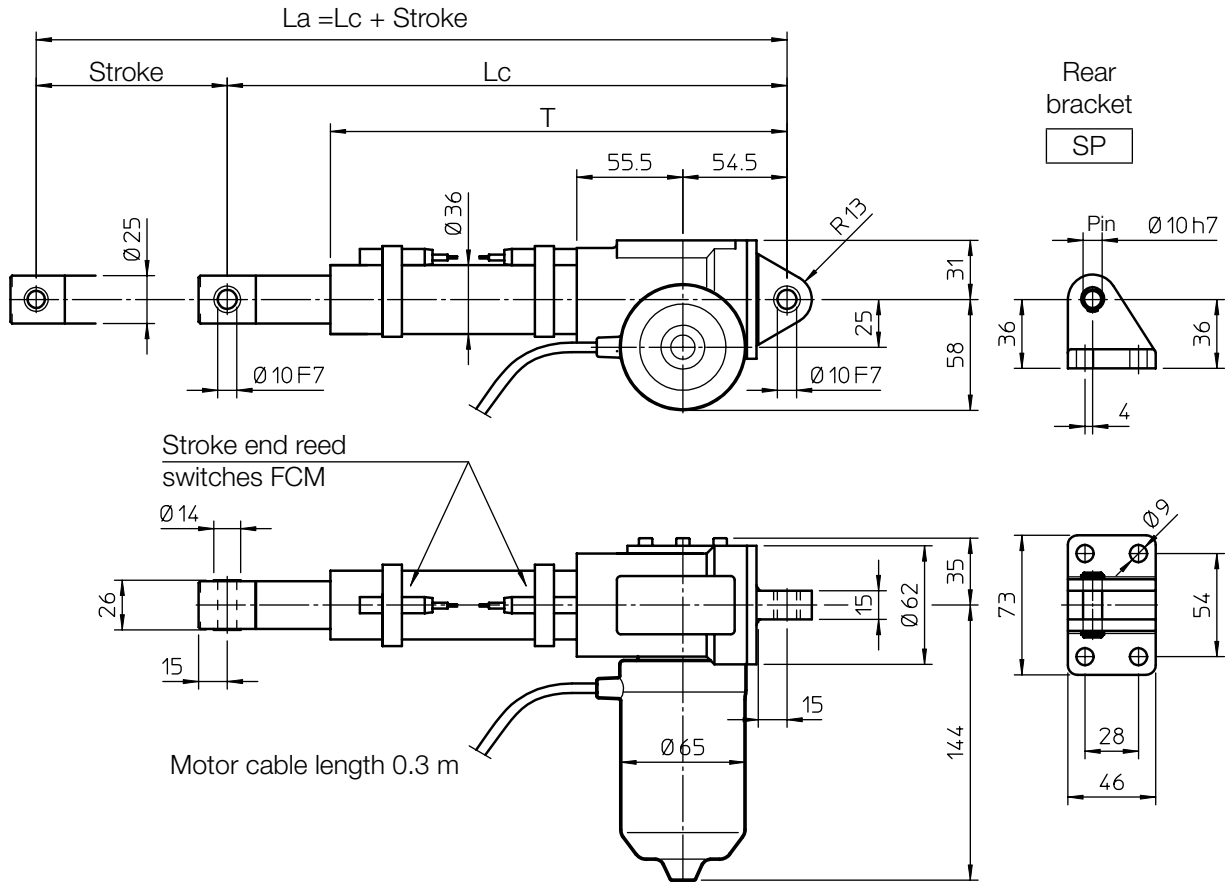

STROKE CODE	STROKE [mm]	LENGTH		T [mm]	MASS [Kg]
		Lc [mm]	La [mm]		
C100	100	327	427	296	3.6
C150	150	377	527	346	3.7
C200	200	427	627	396	3.9
C250	250	477	727	446	4.0
C300	300	527	827	496	4.2
C400	400	627	1027	596	4.5
C500	500	727	1227	696	4.8

PERFORMANCES AND FEATURES

- Pull-Push load up to 5 000 N
- Linear speed up to 64 mm/s
- Standard stroke lengths:
100, 150, 200, 250, 300, 400, 500 mm
- Ball screw BS 14 x 5 (technical details on page 66)
- Aluminium alloy housing and rear attachment with bronze bush
- Anodized aluminium outer tube
- Chrome-plated steel push rod – tolerance f7
- Stainless steel AISI 303 front attachment with bronze bush
- 12, 24 or 36 V DC motor with electromagnetic noise suppressor (motor features details on page 69)

(BRAKE NOT AVAILABLE)

- Duty cycle with max load:
50% over 10 min at (-10 ... +40) °C
- Standard motor mounting position as per sketch (right-hand, code RH)

- Standard protection IP 65
 - Test IP6X according to EN 60529 §12 §13.4-13.6
 - Test IPX5 according to EN 60529 §14.2.5 (tests made with not running actuator)
- Long-life lubrication, maintenance free

ACCESSORIES

- Stainless steel push rod (code SS)
- Rear bracket (code SP)
- Mechanical overload protection: safety clutch (code FS)
- Two adjustable stroke end reed switches (code FCM)
- Extra switch for intermediate position

OPTIONS

- Motor mounting position on opposite side (left-hand, code LH)
- Fixing attachment turned at 90° (code RPT 90)

PERFORMANCES with 24 V DC motor

(Performances with 12 V DC motor: same load, linear speed 10 % less, electrical consumption 2 times more)

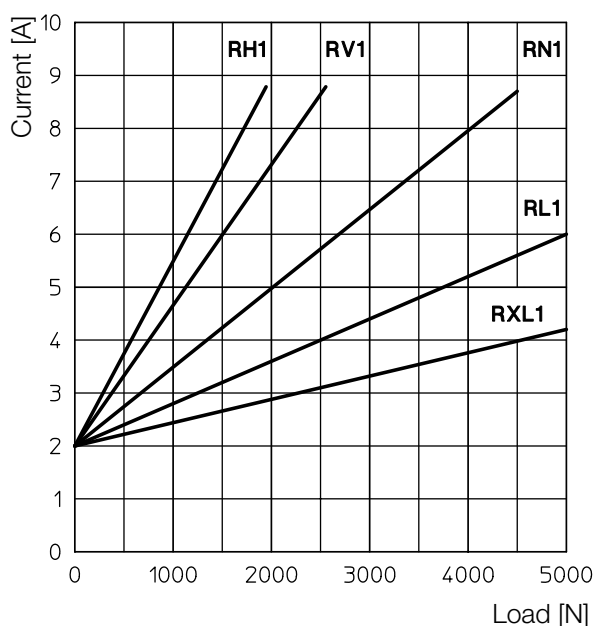
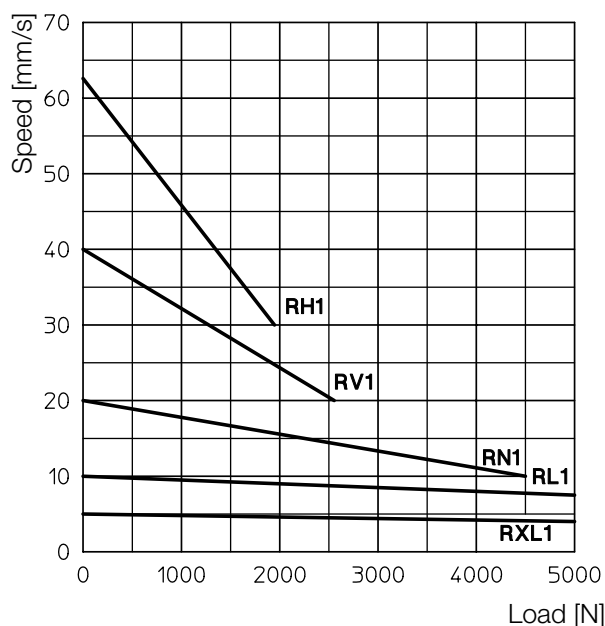

Self-locking conditions

Brake motor not available. Therefore the statically self-locking condition is not achievable. Information about statically self-locking conditions with pull or push load on page 68.

ORDERING CODE EXAMPLE

BSA 08	RL2	C200	CC 24 V	FCM			
Actuator	Selected ratio	Required stroke	Motor	Stroke end switches	Accessories		Options

OVERALL DIMENSIONS

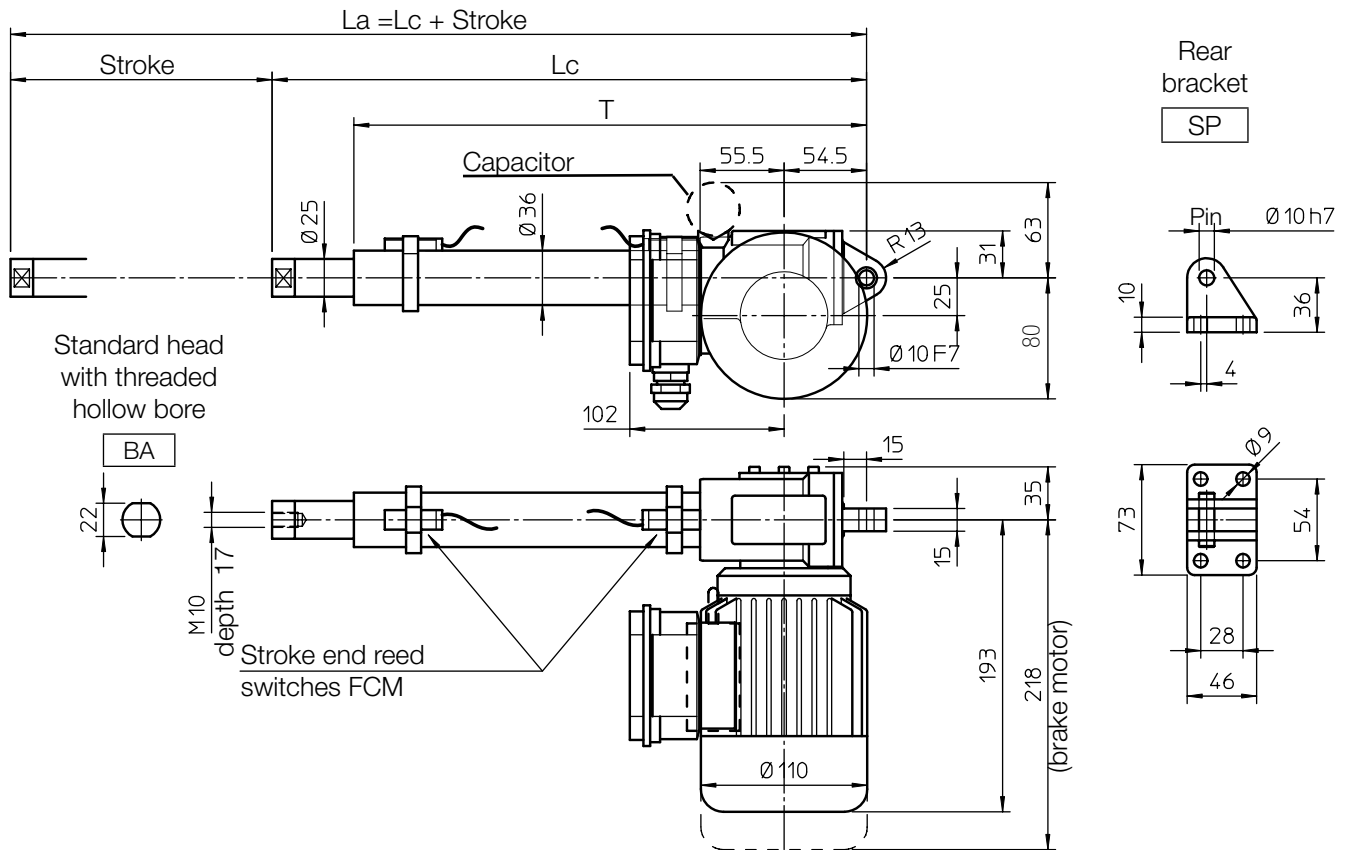

STROKE CODE	Actuator - FCE switches			Actuator - FCM switches			T [mm]	MASS [Kg]	
	STROKE [mm]	LENGTH [mm]		STROKE [mm]	LENGTH [mm]			standard motor	brake motor
		Lc [mm]	La [mm]		Lc [mm]	La [mm]			
C100	85	281	366	53	313	366	239	4.8	5.3
C150	135	331	466	103	363	466	289	4.9	5.4
C200	185	381	566	153	413	566	339	5.1	5.6
C250	235	431	666	203	463	666	389	5.2	5.7
C300	285	481	766	253	513	766	439	5.4	5.9
C400	385	581	966	353	613	966	539	5.7	6.2
C500	485	681	1166	453	713	1166	639	6.0	6.5

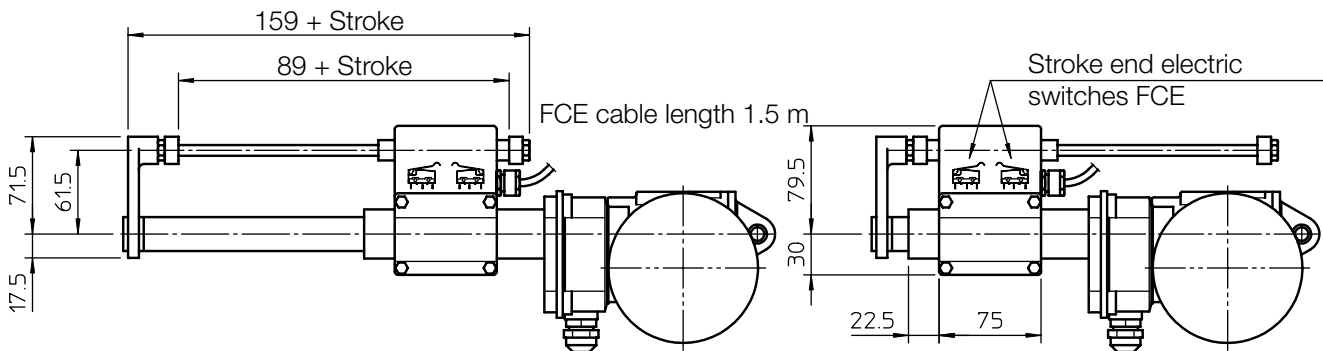

Self-locking conditions

Self-locking condition is achievable with brake motor only.

Information about statically self-locking conditions with pull or push load on page 68.

FRONT ATTACHMENT

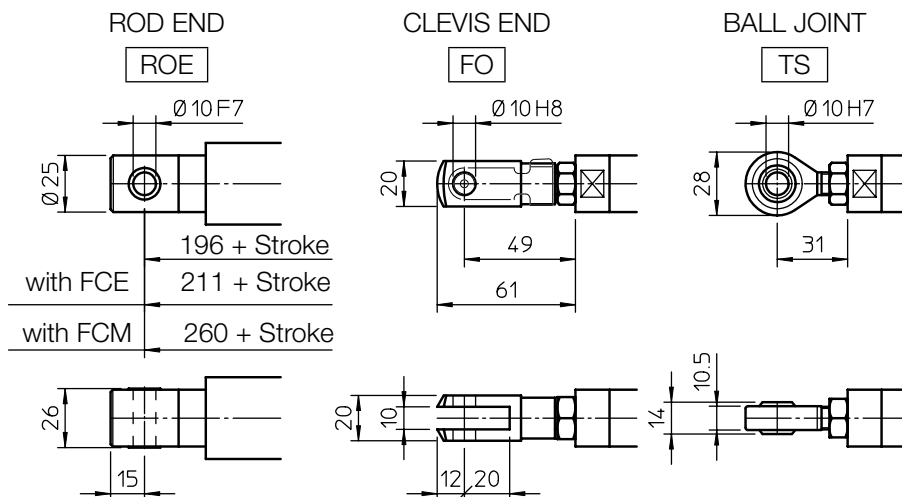

PERFORMANCES AND FEATURES

- Push load up to 5 000 N
- Pull load up to 4 000 N
- Linear speed up to 58 mm/s
- Standard stroke lengths: 100, 150, 200, 250, 300, 400, 500 mm (for different / longer stroke lengths please contact us)
- Ball screw BS 14 x 5 (technical details on page 66)
- Aluminium alloy housing and rear attachment with bronze bush
- Anodized aluminium outer tube
- Chrome-plated steel push rod – tolerance f7
- Standard head BA or rod end ROE in stainless steel AISI 303 with bronze bush
- 3-phase or 1-phase motor (motor features details on page 70)
- Duty cycle with max load: 100% over 10 min at (-10 ... +40) °C
- Standard protection IP 55 (IP 54 with brake)
- Standard motor mounting position as per sketch (right-hand, code RH)
- Long-life lubrication, maintenance free

ACCESSORIES

- Different front attachments
- Stainless steel push rod (code SS)
- Rear bracket (code SP)
- Mechanical overload protection: safety clutch (code FS)
- Brake motor
- Two adjustable stroke end reed switches (code FCM)
- Extra switch for intermediate position
- Electro-mechanical stroke end switch (code FCE) (for linear speed up to 30 mm/s) (technical data on page 72)

OPTIONS

- Motor mounting position on opposite side (left-hand, code LH)
- Fixing attachment turned at 90° (code RPT 90)

PERFORMANCES with AC 3-phase 50 Hz 230/400 V or 1-phase 50 Hz 230 V motor

Ball screw BS 14 x 5				
RATIO	0.09 kW - 4 pole motor		0.12 kW - 2 pole motor	
	LOAD [N]	SPEED [mm/s]	LOAD [N]	SPEED [mm/s]
RH1	2180	29	1490	58
RV1	3290	19	2300	37
RN1	5000	9	4230	19
RL1	5000	4.5	5000	9
RXL1	5000	2.5	5000	4.5

ORDERING CODE EXAMPLE

BSA 10	RL1	C200	CA 230/400 V	FCM				
Actuator	Selected ratio	Required stroke	Motor	Stroke end switches	Accessories			Options

OVERALL DIMENSIONS

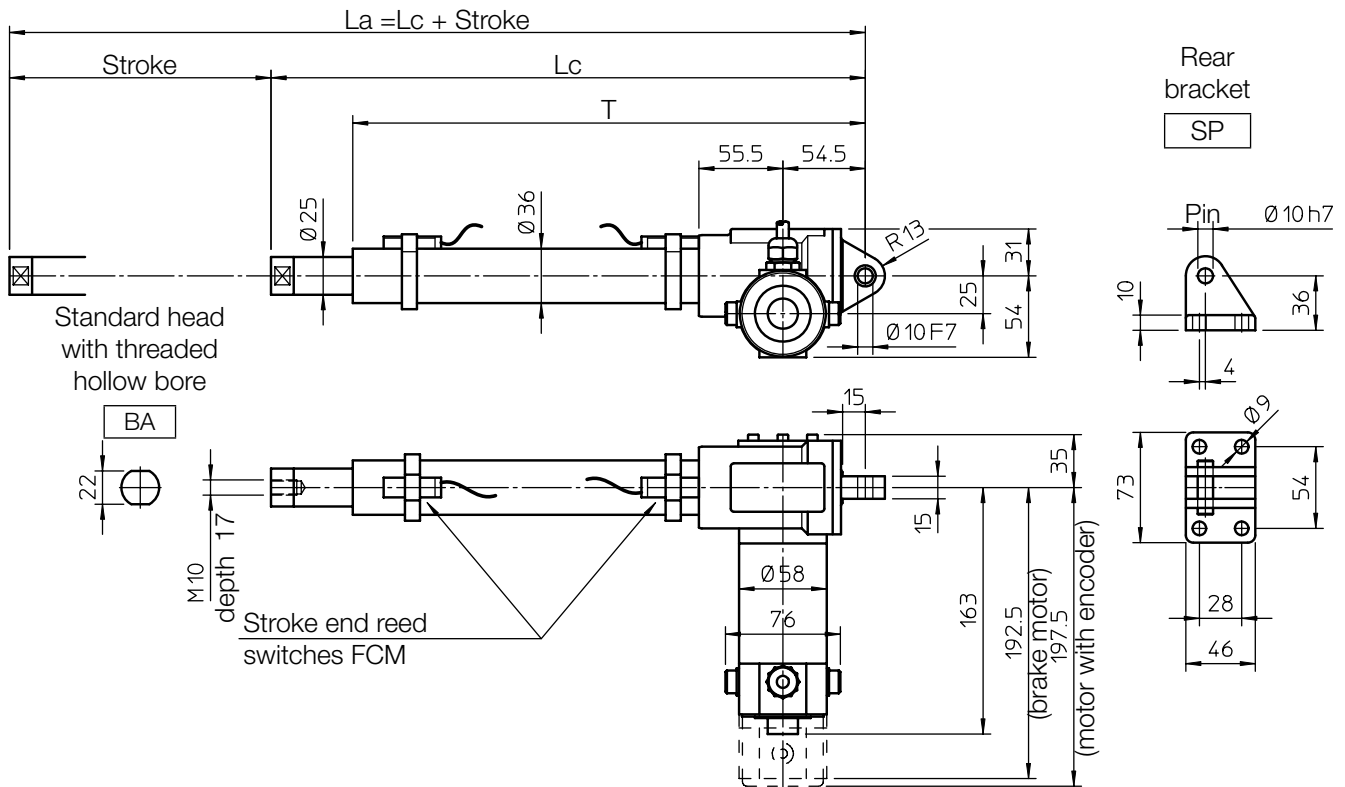

STROKE CODE	Actuator - FCE switches		Actuator - FCM switches			T [mm]	MASS [Kg]		
	STROKE [mm]	LENGTH	STROKE [mm]	LENGTH	STROKE [mm]		standard motor	brake motor	
		Lc [mm]	La [mm]		Lc [mm]	La [mm]			
C100	85	281	366	53	313	366	239	4.8	5.3
C150	135	331	466	103	363	466	289	4.9	5.4
C200	185	381	566	153	413	566	339	5.1	5.6
C250	235	431	666	203	463	666	389	5.2	5.7
C300	285	481	766	253	513	766	439	5.4	5.9
C400	385	581	966	353	613	966	539	5.7	6.2
C500	485	681	1166	453	713	1166	639	6.0	6.5

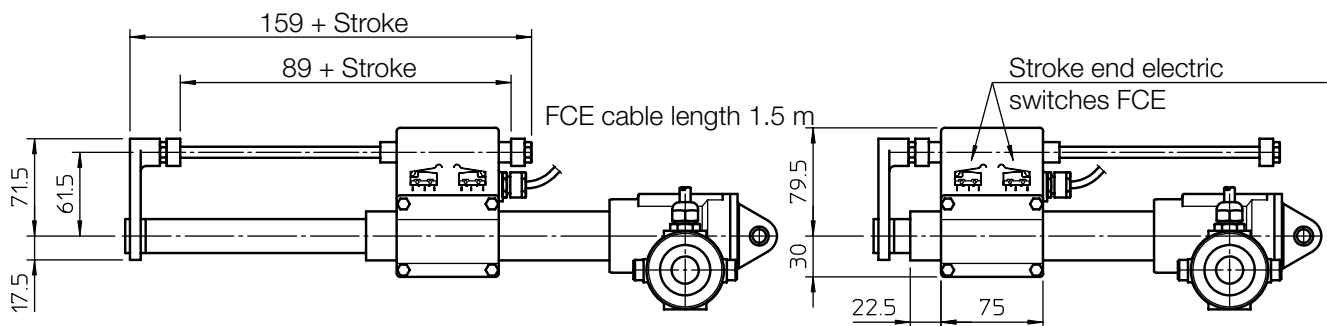

Self-locking conditions

Self-locking condition is achievable with brake motor only.

Information about statically self-locking conditions with pull or push load on page 68.

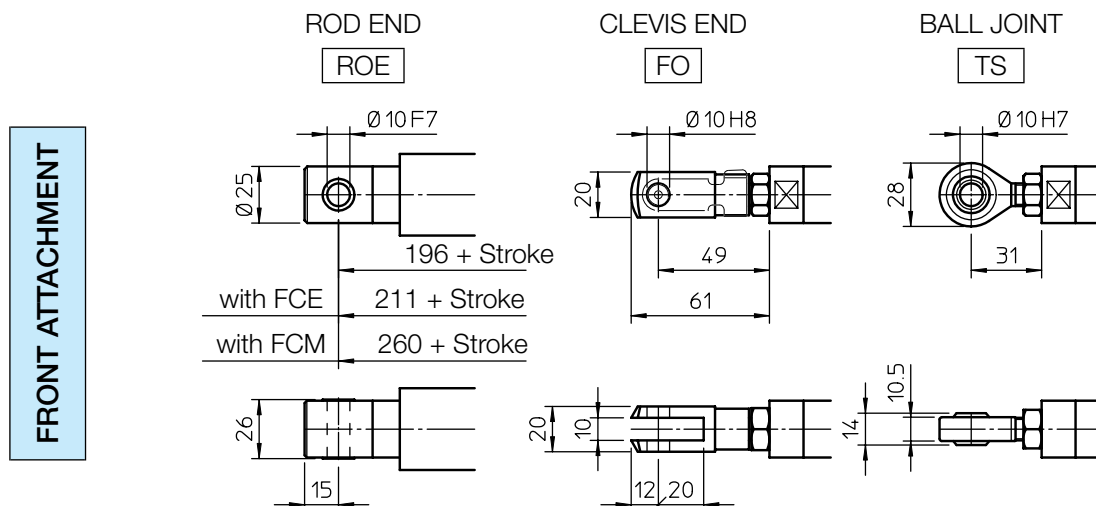

PERFORMANCES AND FEATURES

- Push load up to 5 000 N
- Pull load up to 4 000 N
- Linear speed up to 63 mm/s
- Standard stroke lengths: 100, 150, 200, 250, 300, 400, 500 mm (for different / longer stroke lengths please contact us)
- Ball screw BS 14 x 5 (technical details on page 66)
- Aluminium alloy housing and rear attachment with bronze bush
- Anodized aluminium outer tube
- Chrome-plated steel push rod – tolerance f7
- Standard head BA or rod end ROE in stainless steel AISI 303 with bronze bush
- 12 or 24 V DC motor (motor features details on page 69)
- Duty cycle with max load: 100% over 10 min at (-10 ... +40) °C
- Standard protection IP 54
- Standard motor mounting position as per sketch (right-hand, code RH)
- Long-life lubrication, maintenance free

ACCESSORIES

- Different front attachments
- Stainless steel push rod (code SS)
- Rear bracket (code SP)
- Mechanical overload protection: safety clutch (code FS)
- Brake motor
- Two adjustable stroke end reed switches (code FCM)
- Extra switch for intermediate position
- Electro-mechanical stroke end switch (code FCE) (for linear speed up to 30 mm/s) (technical data on page 72)
- Bi-directional incremental encoder, 100 ppr with zero set pulse, Push-Pull, 8÷24 Vcc (code EH38) (encoder features details on page 75)

OPTIONS

- Motor mounting position on opposite side (left-hand, code LH)
- Fixing attachment turned at 90° (code RPT 90)

PERFORMANCES with 24 V DC motor

(Performances with 12 V DC motor: same load, linear speed 10 % less, electrical consumption 2 times more)

Ball screw BS 14 x 5			
RATIO	LOAD [N]	SPEED [mm/s]	CURRENT [A]
RH1	800	63	4
RV1	1260	40	4
RN1	2350	20	4
RL1	4130	10	4
RXL1	5000	5	3

ORDERING CODE EXAMPLE

BSA 10	RL1	C200	CC 24 V	FCM				
Actuator	Selected ratio	Required stroke	Motor	Stroke end switches	Accessories			Options

OVERALL DIMENSIONS

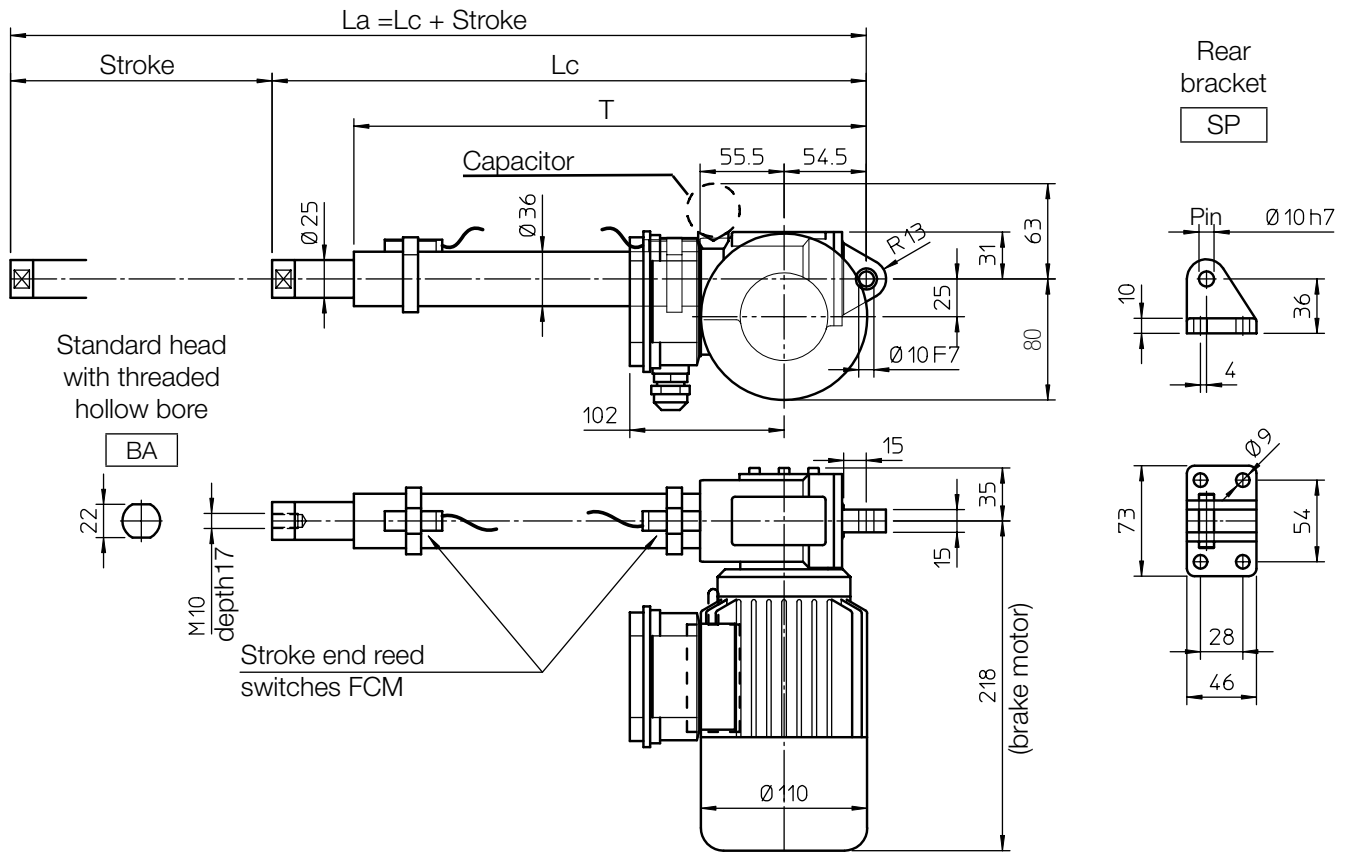

Length [mm]	
L_c	243 + Stroke
T	212 + Stroke

STROKE CODE	STROKE [mm]	LENGTH		T [mm]	MASS [Kg]
		L_c [mm]	L_a [mm]		
C100	100	343	443	312	5.4
C150	150	393	543	362	5.5
C200	200	443	643	412	5.7
C250	250	493	743	462	5.8
C300	300	543	843	512	6.0
C400	400	643	1043	612	6.3
C500	500	743	1243	712	6.6

Self-locking conditions

Self-locking condition is achievable with brake motor only.

Information about statically self-locking conditions with pull or push load on page 68.

FRONT ATTACHMENT

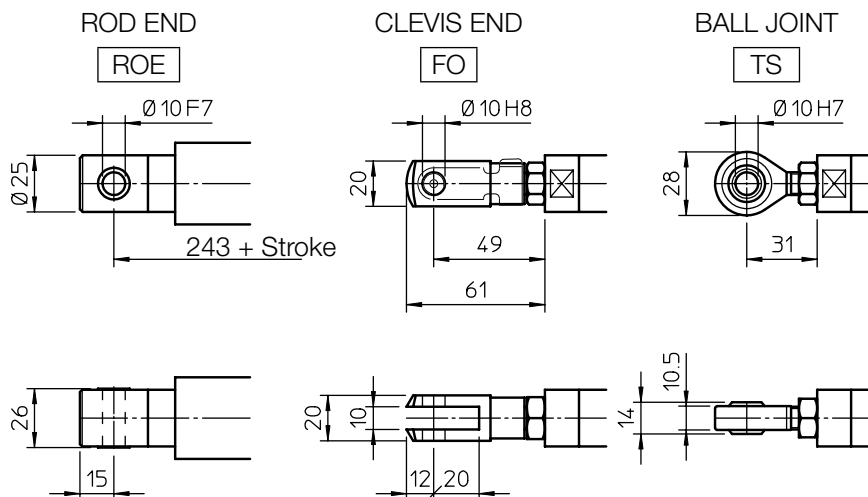

PERFORMANCES AND FEATURES

- Push load up to 5 000 N
- Pull load up to 4 000 N
- Linear speed up to 117 mm/s
- Standard stroke lengths:
100, 150, 200, 250, 300, 400, 500 mm
(for different / longer stroke lengths please contact us)
- Ball screw BS 14 x 10 (technical details on page 66)
- Aluminium alloy housing and rear attachment with bronze bush
- Anodized aluminium outer tube
- Chrome-plated steel push rod – tolerance f7
- Standard head BA or rod end ROE in stainless steel AISI 303 with bronze bush
- AC 3-phase or 1-phase brakemotor (motor features details on page 70)
- Duty cycle with max load:
100% over 10 min at (-10 ... +40) °C

- Standard motor mounting position as per sketch (right-hand, code RH)
- Standard protection IP 54
- Long-life lubrication, maintenance free

ACCESSORIES

- Different front attachments
- Stainless steel push rod (code SS)
- Rear bracket (code SP)
- Mechanical overload protection: safety clutch (code FS)
- Two adjustable stroke end reed switches (code FCM)
- Extra switch for intermediate position

OPTIONS

- Motor mounting position on opposite side (left-hand, code LH)
- Fixing attachment turned at 90° (code RPT 90)

PERFORMANCES with AC 3-phase 50 Hz 230/400 V or 1-phase 50 Hz 230 V motor

Ball screw BS 14 x 10				
RATIO	0.09 kW - 4 pole motor		0.12 kW - 2 pole motor	
	LOAD [N]	SPEED [mm/s]	LOAD [N]	SPEED [mm/s]
RH2	1120	58	760	117
RV2	1730	37	1170	75
RN2	3100	19	2220	37
RL2	5000	9.5	3790	19

ORDERING CODE EXAMPLE

BSA 11	RL1	C200	CA 230/400 V	FCM				
Actuator	Selected ratio	Required stroke	Motor	Stroke end switches	Accessories			Options

OVERALL DIMENSIONS

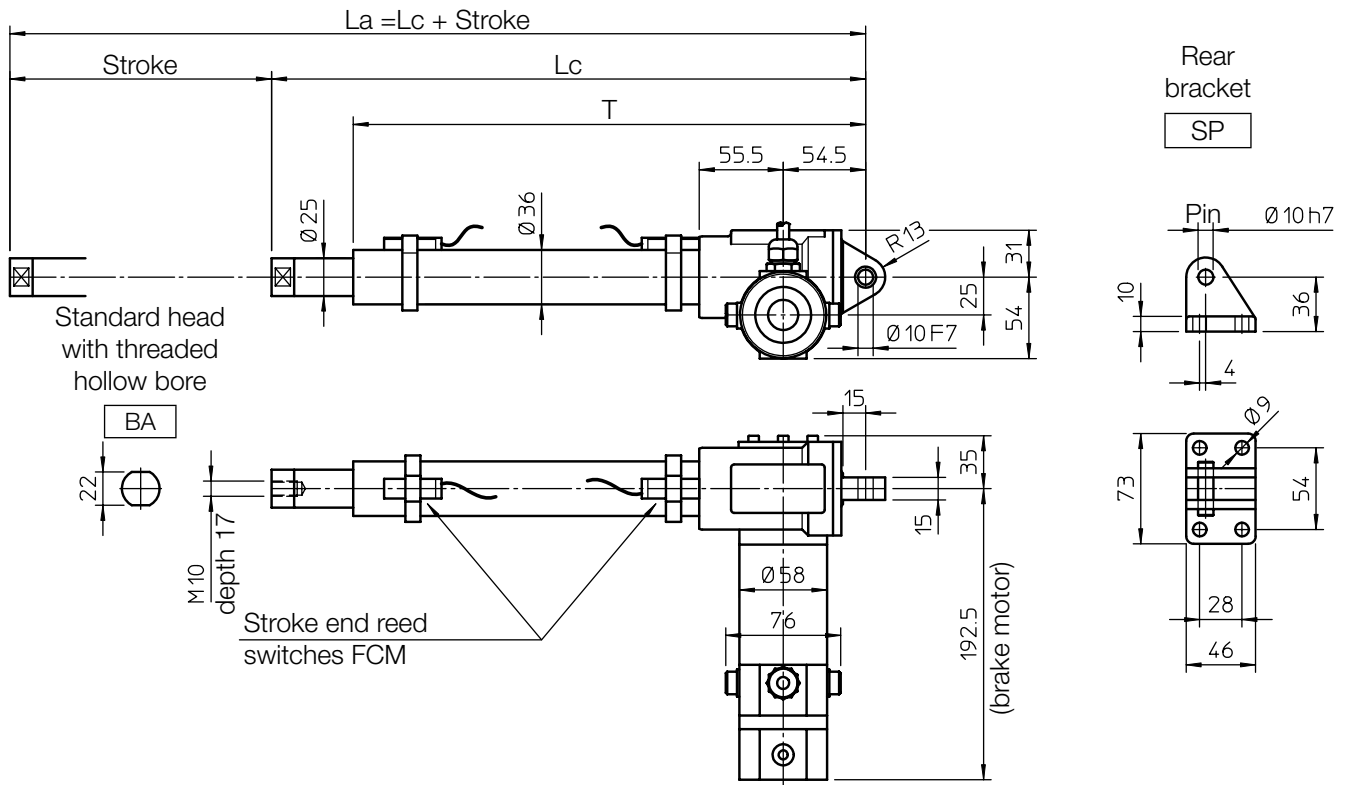

Length [mm]	
Lc	243 + Stroke
T	212 + Stroke

STROKE CODE	STROKE [mm]	LENGTH		T [mm]	MASS [Kg]
		Lc [mm]	La [mm]		
C100	100	343	443	312	4.1
C150	150	393	543	362	4.2
C200	200	443	643	412	4.4
C250	250	493	743	462	4.5
C300	300	543	843	512	4.7
C400	400	643	1043	612	5.0
C500	500	743	1243	712	5.3

Self-locking conditions

Self-locking condition is achievable with brake motor only.

Information about statically self-locking conditions with pull or push load on page 68.

FRONT ATTACHMENT

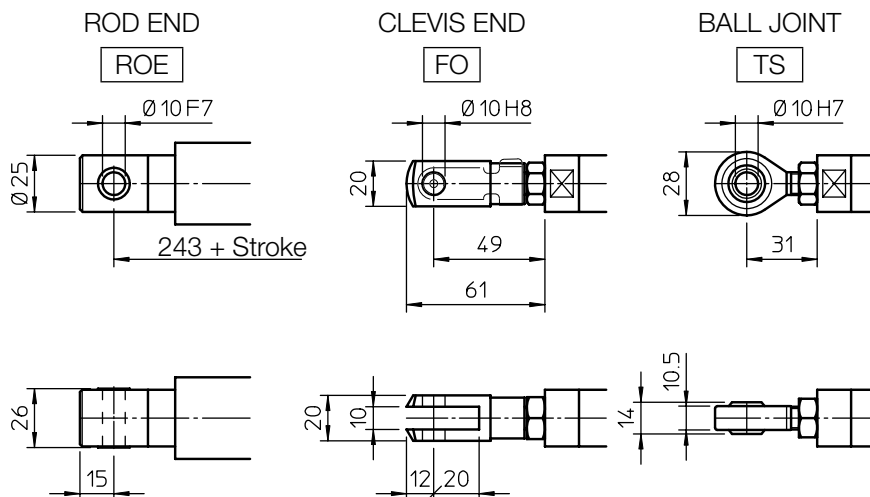

PERFORMANCES AND FEATURES

- Push-Pull load up to 5 000 N
- Linear speed up to 125 mm/s
- Standard stroke lengths: 100, 150, 200, 250, 300, 400, 500 mm (for different / longer stroke lengths please contact us)
- Ball screw BS 14 x 10 (technical details on page 66)
- Aluminium alloy housing and rear attachment with bronze bush
- Anodized aluminium outer tube
- Chrome-plated steel push rod – tolerance f7
- Standard head BA or rod end ROE in stainless steel AISI 303 with bronze bush
- 12 or 24 V DC brakemotor (motor features details on page 69)
- Duty cycle with max load: 100% over 10 min at (-10 ... +40) °C

- Standard motor mounting position as per sketch (right-hand, code RH)
- Standard protection IP 54
- Long-life lubrication, maintenance free

ACCESSORIES

- Different front attachments
- Stainless steel push rod (code SS)
- Rear bracket (code SP)
- Mechanical overload protection: safety clutch (code FS)
- Two adjustable stroke end reed switches (code FCM)
- Extra switch for intermediate position

OPTIONS

- Motor mounting position on opposite side (left-hand, code LH)
- Fixing attachment turned at 90° (code RPT 90)

PERFORMANCES with 24 V DC motor

(Performances with 12 V DC motor: same load, linear speed 10 % less, electrical consumption 2 times more)

Ball screw BS 14 x 10			
RATIO	LOAD [N]	SPEED [mm/s]	CURRENT [A]
RH2	410	125	4
RV2	640	80	4
RN2	1200	40	4
RL2	2100	20	4

ORDERING CODE EXAMPLE

BSA 11	RL1	C200	CC 24 V	FCM					
Actuator	Selected ratio	Required stroke	Motor	Stroke end switches	Accessories			Options	

OVERALL DIMENSIONS

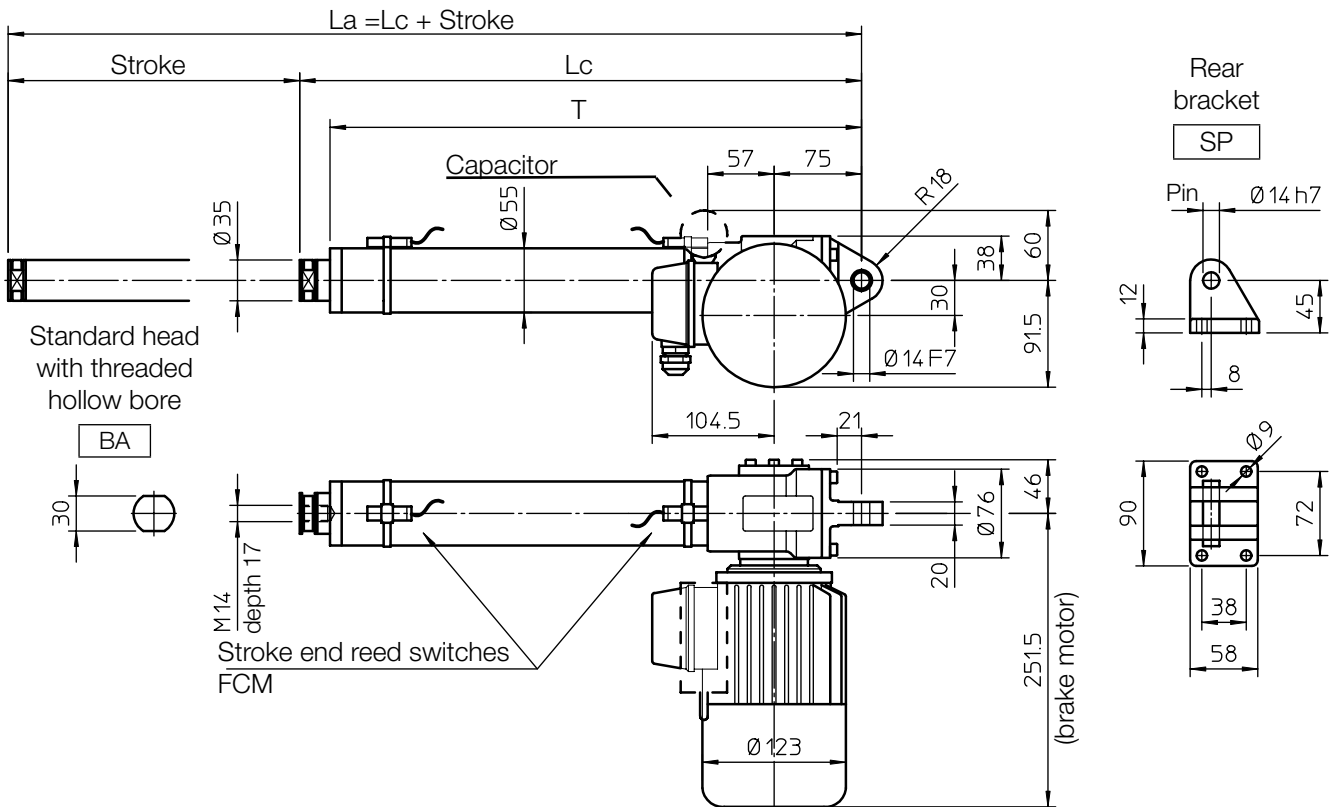

Length	Actuator
Lc [mm]	279 + Stroke
T [mm]	238 + Stroke

STROKE CODE	STROKE [mm]	LENGTH		T [mm]	MASS [Kg]
		Lc [mm]	La [mm]		
C100	100	379	479	338	8.9
C200	200	479	679	438	9.7
C300	300	579	879	538	10.5
C400	400	679	1079	638	11.3
C500	500	779	1279	738	12.1
C600	600	879	1479	838	12.9
C700	700	979	1679	938	13.7
C800	800	1079	1879	1038	14.5

Self-locking conditions

Self-locking condition is achievable with brake motor only.

Information about statically self-locking conditions with pull or push load on page 68.

FRONT ATTACHMENT

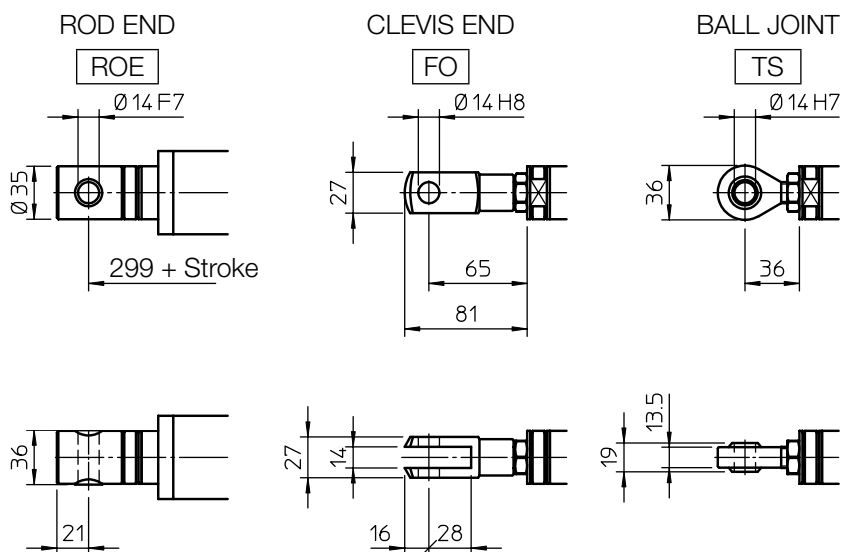

PERFORMANCES AND FEATURES

- Push-Pull load up to 9 000 N
- Linear speed up to 58 mm/s
- Standard stroke lengths: 100, 200, 300, 400, 500, 600, 700, 800 mm
- Ball screw BS 20 x 5 (technical details on page 66)
- Aluminium alloy housing and rear attachment with bronze bush
- Anodized aluminium outer tube
- Chrome-plated steel push rod – tolerance f7
- Standard head BA or rod end ROE in stainless steel AISI 303 with bronze bush
- AC 3-phase or 1-phase brakemotor (motor features details on page 70)
- Duty cycle with max load: 100% over 10 min at (-10 ... +40) °C
- Standard motor mounting position as per sketch (right-hand, code RH)
- Standard protection IP 54
- Long-life lubrication, maintenance free

ACCESSORIES

- Different front attachments
- Stainless steel push rod (code SS)
- Rear bracket (code SP)
- Mechanical overload protection: safety clutch (code FS)
- Two adjustable stroke end reed switches (code FCM)
- Extra switch for intermediate position

OPTIONS

- Motor mounting position on opposite side (left-hand, code LH)
- Fixing attachment turned at 90° (code RPT 90)

PERFORMANCES with AC 3-phase 50 Hz 230/400 V or 1-phase 50 Hz 230 V motor

Ball screw BS 20 x 5				
RATIO	0.18 kW - 4 pole motor		0.25 kW - 2 pole motor	
	LOAD [N]	SPEED [mm/s]	LOAD [N]	SPEED [mm/s]
RV1	4300	29	3060	58
RN1	9000	7	9000	14
RL1	9000	3.5	9000	7

ORDERING CODE EXAMPLE

BSA 12	RL1	C200	CA 230/400 V	FCM				
Actuator	Selected ratio	Required stroke	Motor	Stroke end switches	Accessories			Options

OVERALL DIMENSIONS

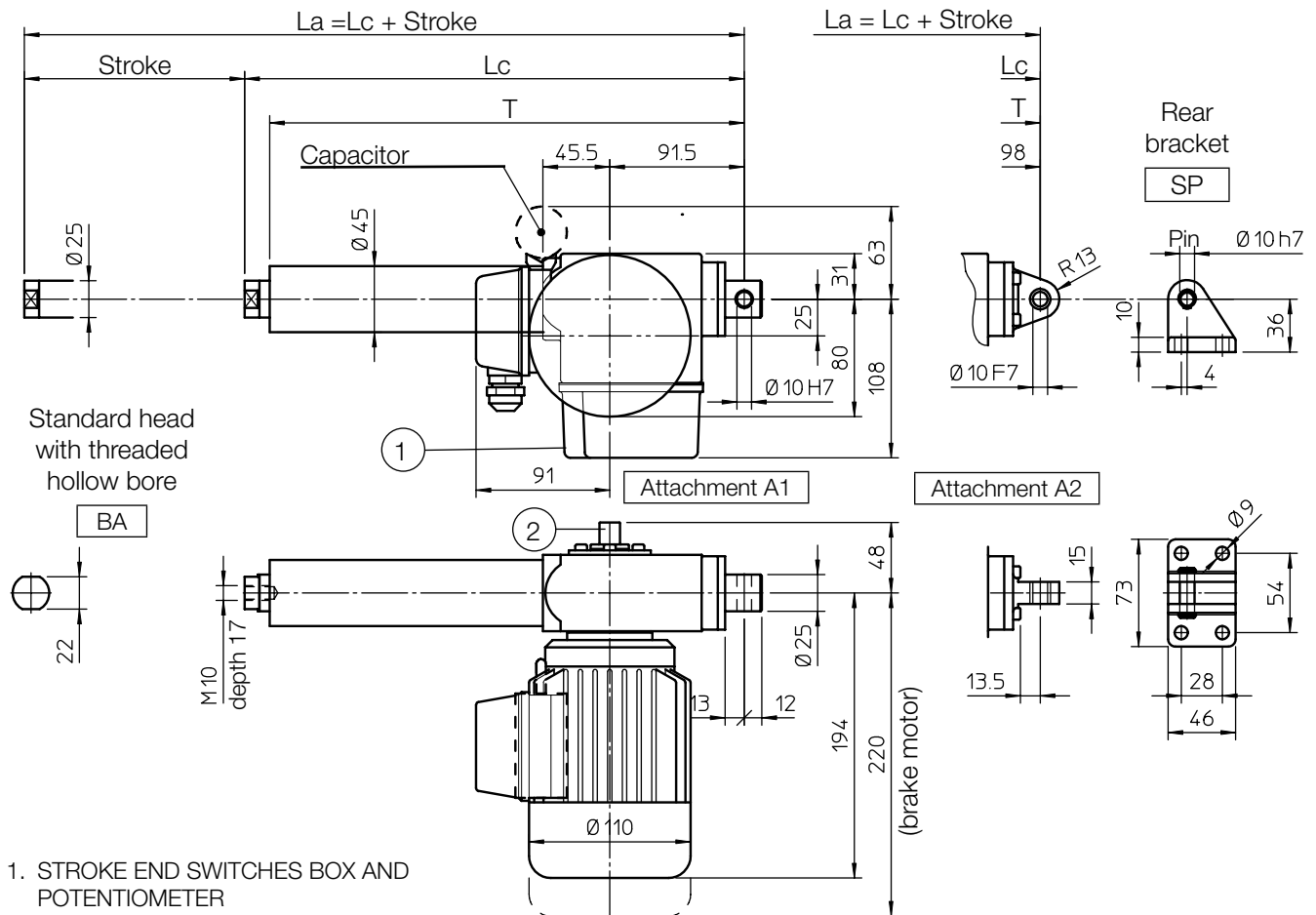

1. STROKE END SWITCHES BOX AND POTENTIOMETER
2. MOTOR SHAFT EXTENSION for:
Emergency manual activation
Stroke end switches and potentiometer adjustment

Q [mm]	Attachment A1	Attachment A2
	253	260

STROKE CODE	Actuator - Attachment A1				Actuator - Attachment A2				MASS [Kg]	
	STROKE [mm]	LENGTH [mm]		T [mm]	STROKE [mm]	LENGTH [mm]		T [mm]	standard motor	brake motor
C100	100	Lc 348	La 448	317	100	Lc 355	La 455	324	5.2	5.7
C150	150	Lc 398	La 548	367	150	Lc 405	La 555	374	5.3	5.8
C200	200	Lc 448	La 648	417	200	Lc 455	La 655	424	5.5	6.0
C250	250	Lc 498	La 748	467	250	Lc 505	La 755	474	5.6	6.1
C300	300	Lc 548	La 848	517	300	Lc 555	La 855	524	5.8	6.3
C400	400	Lc 648	La 1048	617	400	Lc 655	La 1055	624	6.1	6.6

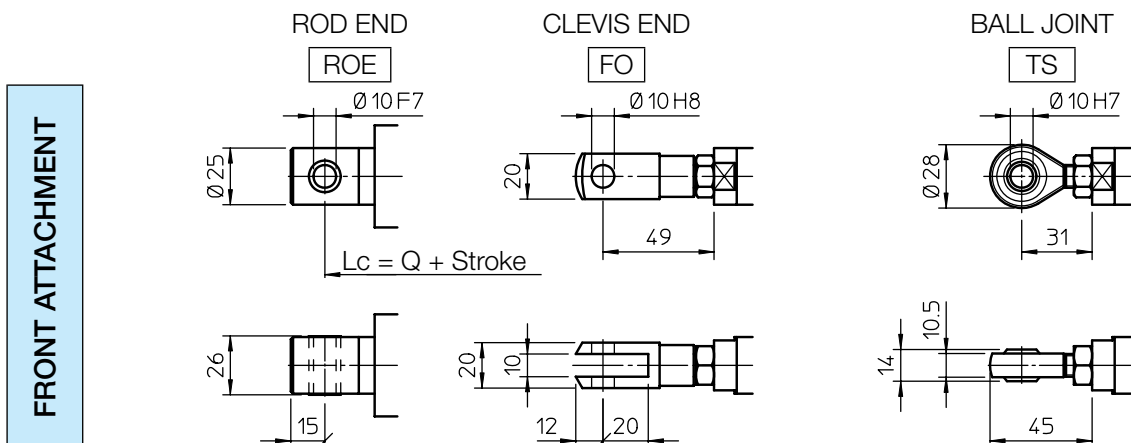

PERFORMANCES AND FEATURES

- Push load up to 5 000 N
- Pull load up to 4 000 N
- Linear speed up to 117 mm/s
- Standard stroke lengths:
100, 150, 200, 250, 300, 400 mm
- Ball screw BS 14 x 5 or BS 14 x 10
(technical details on page 66)
- Aluminium alloy housing
- Anodized aluminium outer tube
- Chrome-plated steel push rod – tolerance f7
- Rear attachment:
 - A1: zinc-plated steel rod end with bronze bush
 - A2: aluminium alloy with bronze bush
- Standard head BA or rod end ROE
in stainless steel AISI 303 with bronze bush
- AC 3-phase or 1-phase motor
(motor features details on page 70)
- Duty cycle with max load:
100% over 10 min at (-10 ... +40) °C
- Standard protection IP 55 (IP 54 with brake)
- Standard motor mounting position as per sketch
(right-hand, code RH)
- Long-life lubrication, maintenance free

ACCESSORIES

- Different front attachments
- Stainless steel push rod (code SS)
- Rear bracket (code SP)
with rear attachment A2
- Mechanical overload protection:
safety clutch (code FS)
- Brakemotor
- Adjustable electric stroke end switches (code FC2)
- Adjustable electric stroke end switches,
switching off the motor (code FC2X)
(not available with AC 3-phase motor)
- Extra switch for intermediate position (code FC)
- Rotative potentiometer 5kOhm for positioning control
(code POR5K)

NOTE: Extra limit switch and rotative potentiometer cannot be selected together

OPTIONS

- Motor mounting position on opposite side
(left-hand, code LH)
- Fixing attachment turned at 90° (code RPT 90)

PERFORMANCES with AC 3-phase 50 Hz 230/400 V or 1-phase 50 Hz 230 V motor

Ball screw BS 14 x 5				
RATIO	0.09 kW - 4 pole motor		0.12 kW - 2 pole motor	
	LOAD [N]	SPEED [mm/s]	LOAD [N]	SPEED [mm/s]
RH1	2170	29	1490	58
RV1	3270	19	2300	37
RN1	5000	9.5	4230	19
RL1	5000	4.5	5000	9.5
RXL1	5000	2.5	5000	4.5

Ball screw BS 14 x 10				
RATIO	0.09 kW - 4 pole motor		0.12 kW - 2 pole motor	
	LOAD [N]	SPEED [mm/s]	LOAD [N]	SPEED [mm/s]
RH2	1120	58	760	117
RV2	1730	37	1170	75
RN2	3100	19	2220	37
RL2	5000	9.5	3790	19

Self-locking conditions

Self-locking condition is achievable with brake motor only.

Information about statically self-locking conditions with pull or push load on page 68.

ORDERING CODE EXAMPLE

CLB 25	RL1	C200	CA 230/400 V	FC2	POR 5K				
Actuator	Selected ratio	Required stroke	Motor	Stroke end switches	Accessories			Options	

OVERALL DIMENSIONS

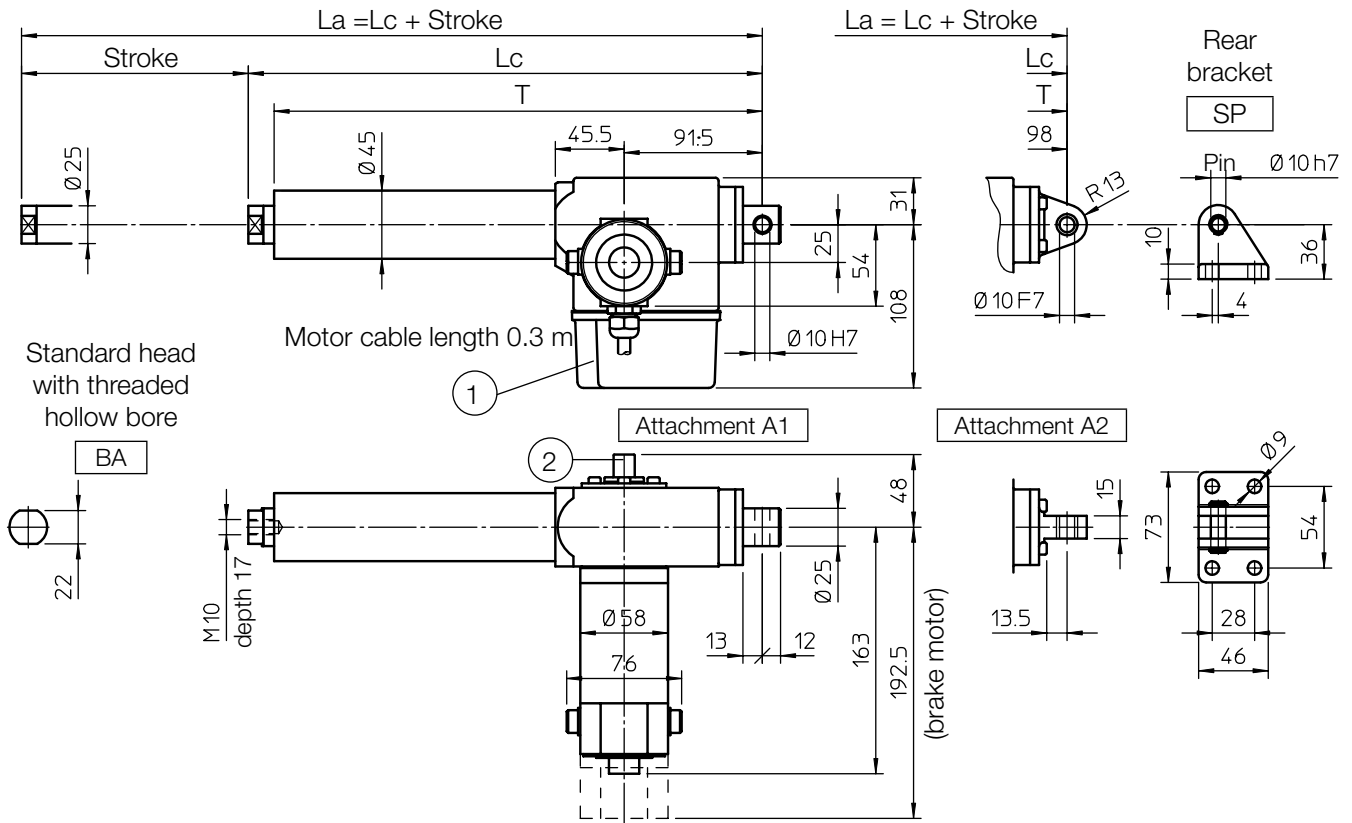

1. STROKE END SWITCHES BOX AND POTENTIOMETER
2. MOTOR SHAFT EXTENSION for:
 - Emergency manual activation
 - Stroke end switches and potentiometer adjustment

Q [mm]	Attachment A1	Attachment A2
	253	260

STROKE CODE	Actuator - Attachment A1			Actuator - Attachment A2			MASS [Kg]		
	STROKE [mm]	LENGTH	T [mm]	STROKE [mm]	LENGTH	T [mm]			
		L_c [mm]	L_a [mm]		L_c [mm]	L_a [mm]			
C100	100	348	448	317	100	355	455	324	5.2
C150	150	398	548	367	150	405	555	374	5.3
C200	200	448	648	417	200	455	655	424	5.5
C250	250	498	748	467	250	505	755	474	5.6
C300	300	548	848	517	300	555	855	524	5.8
C400	400	648	1048	617	400	655	1055	624	6.1

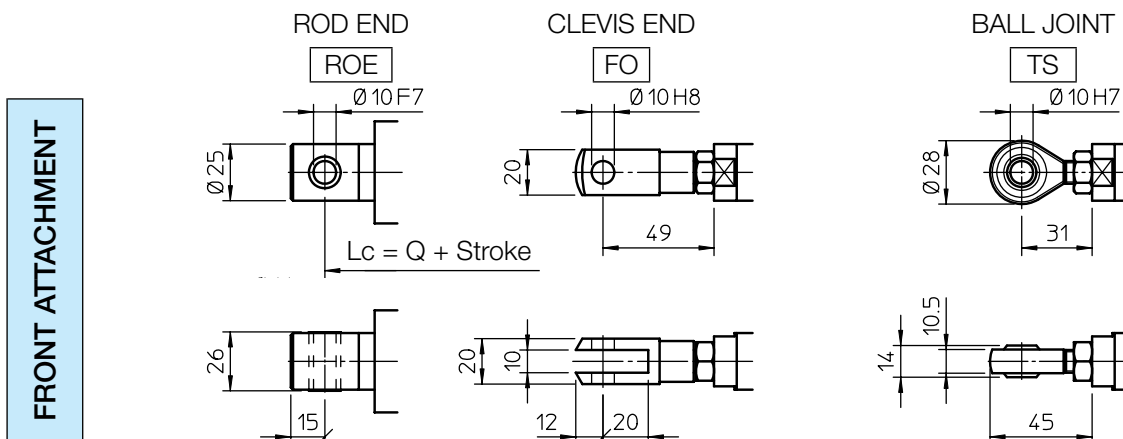

PERFORMANCES AND FEATURES

- Push load up to 5 000 N
- Pull load up to 4 000 N
- Linear speed up to 125 mm/s
- Standard stroke lengths:
100, 150, 200, 250, 300, 400 mm
- Ball screw BS 14 x 5 or BS 14 x 10
(technical details on page 66)
- Aluminium alloy housing
- Anodized aluminium outer tube
- Chrome-plated steel push rod – tolerance f7
- Rear attachment:
 - A1: zinc-plated steel rod end with bronze bush
 - A2: aluminium alloy with bronze bush
- Standard head BA or rod end ROE
in stainless steel AISI 303 with bronze bush
- 12 or 24 V DC brakemotor
(motor features details on page 69)
- Duty cycle with max load:
100% over 10 min at (-10 ... +40) °C
- Standard protection IP 54
- Standard motor mounting position as per sketch
(right-hand, code RH)
- Long-life lubrication, maintenance free

ACCESSORIES

- Different front attachments
- Stainless steel push rod (code SS)
- Rear bracket (code SP)
with rear attachment A2
- Mechanical overload protection:
safety clutch (code FS)
- Adjustable electric stroke end switches
(code FC2)
- Adjustable electric stroke end switches,
switching off the motor (code FC2X)
- Extra switch for intermediate position (code FC)
- Rotative potentiometer 5kOhm
for positioning control
(code POR5K)

NOTE: Extra limit switch and rotative potentiometer cannot be selected together

OPTIONS

- Motor mounting position on opposite side
(left-hand, code LH)
- Fixing attachment turned at 90° (code RPT 90)

PERFORMANCES with 24 V DC motor

(Performances with 12 V DC motor: same load, linear speed 10 % less, electrical consumption 2 times more)

Ball screw BS 14 x 5			
RATIO	LOAD [N]	SPEED [mm/s]	CURRENT [A]
RH1	800	63	4
RV1	1260	40	4
RN1	2350	20	4
RL1	4130	10	4
RXL1	5000	5	3

Ball screw BS 14 x 10			
RATIO	LOAD [N]	SPEED [mm/s]	CURRENT [A]
RH2	410	125	4
RV2	640	80	4
RN2	1200	40	4
RL2	2100	20	4

Self-locking conditions

Self-locking condition is achievable with brake motor only.

Information about statically self-locking conditions with pull or push load on page 68.

ORDERING CODE EXAMPLE

CLB 25	RL1	C200	CC 24 V	FC2	POR 5K				
Actuator	Selected ratio	Required stroke	Motor	Stroke end switches	Accessories			Options	

OVERALL DIMENSIONS

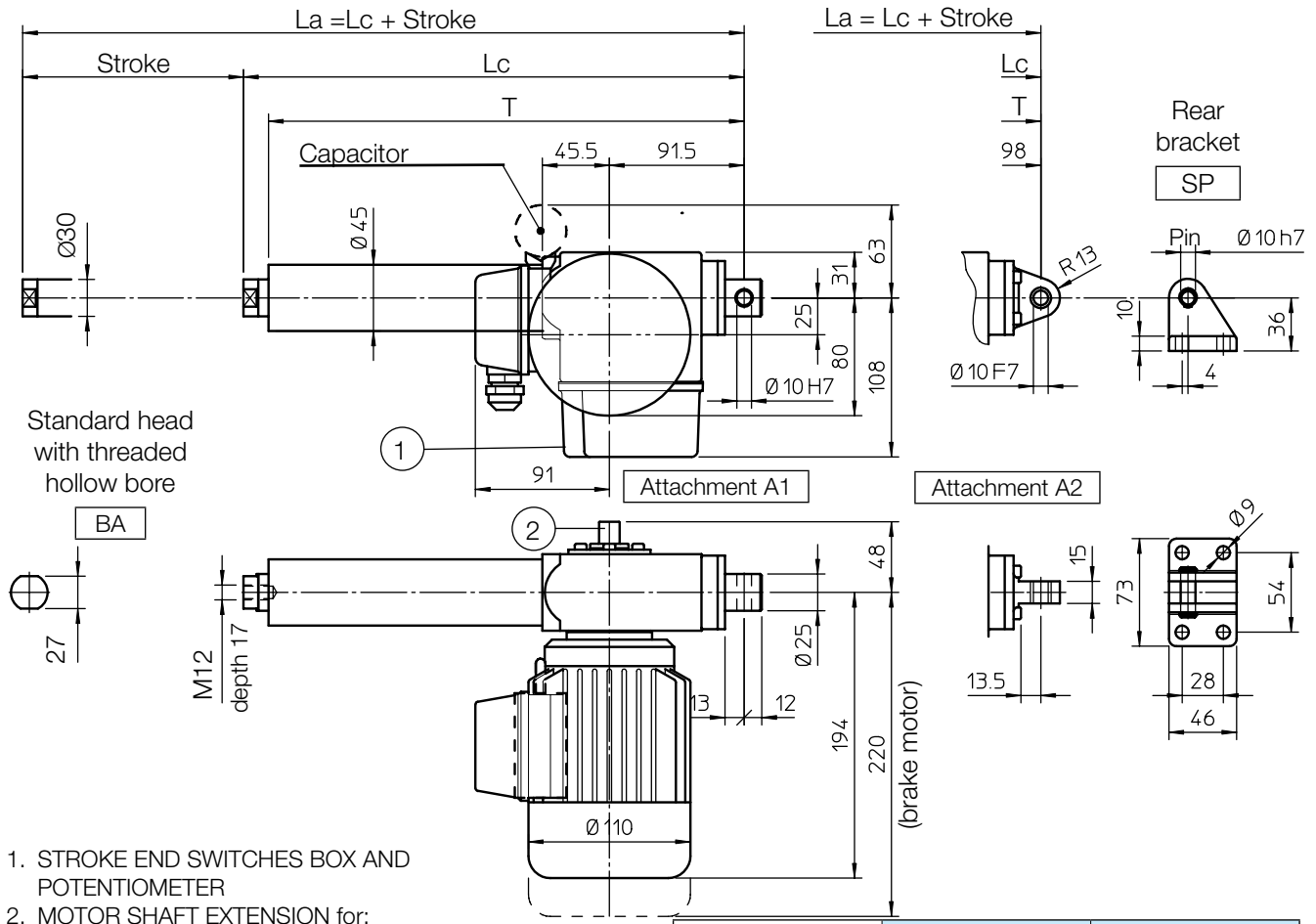

1. STROKE END SWITCHES BOX AND POTENTIOMETER
2. MOTOR SHAFT EXTENSION for:
Emergency manual activation
Stroke end switches and potentiometer adjustment

Q [mm]	Attachment A1	Attachment A2
	239	246

STROKE CODE	Actuator - Attachment A1				Actuator - Attachment A2				MASS [Kg]	
	STROKE [mm]	LENGTH		T [mm]	STROKE [mm]	LENGTH		T [mm]	standard motor	brake motor
		Lc [mm]	La [mm]			Lc [mm]	La [mm]			
C100	100	336	436	300	100	343	443	307	5.3	5.8
C150	150	386	536	350	150	393	543	357	5.5	6.0
C200	200	436	636	400	200	443	643	407	5.7	6.2
C300	300	536	836	500	300	543	843	507	6.1	6.6
C400	400	636	1036	600	400	643	1043	607	6.5	7.0
C500	500	736	1236	700	500	743	1243	707	6.9	7.4

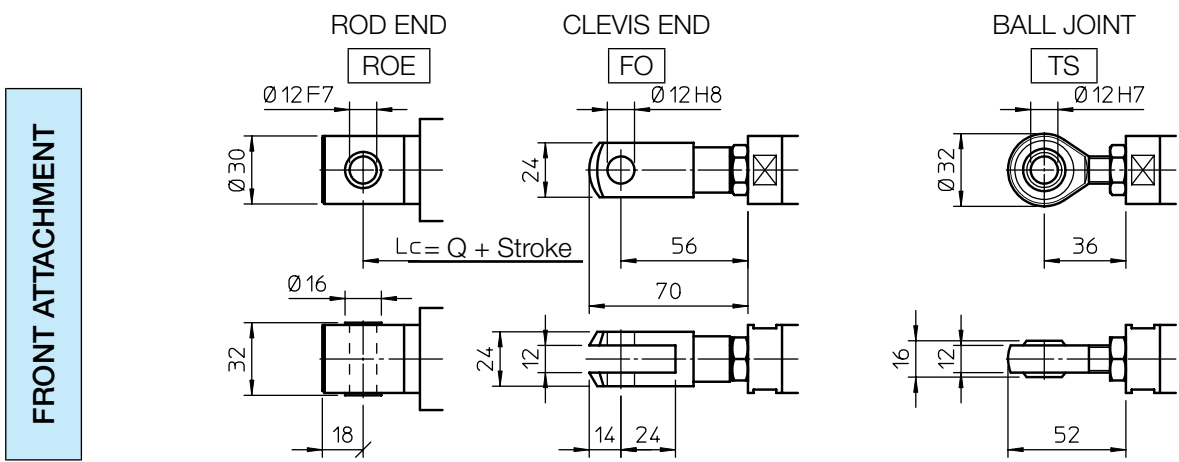

PERFORMANCES AND FEATURES

- Push load up to 7 000 N
- Pull load up to 4 000 N
- Linear speed up to 58 mm/s
- Standard stroke lengths:
100, 150, 200, 300, 400, 500 mm
- Ball screw BS 16 x 5 (technical details on page 66)
- Aluminium alloy housing
- Anodized aluminium outer tube
- Chrome-plated steel push rod
- Rear attachment:
 - A1: zinc-plated steel rod end with bronze bush
 - A2: aluminium alloy with bronze bush
- Standard head BA or rod end ROE
in stainless steel AISI 303 with bronze bush
- AC 3-phase or 1-phase motor
(motor features details on page 70)
- Duty cycle with max load:
100% over 10 min at (-10 ... +40) °C
- Standard protection IP 55 (IP 54 with brake)
- Standard motor mounting position as per sketch
(right-hand, code RH)
- Long-life lubrication, maintenance free

ACCESSORIES

- Different front attachments
- Stainless steel push rod (code SS)
- Rear bracket (code SP) with rear attachment A2
- Mechanical overload protection:
safety clutch (code FS)
- Brakemotor
- Adjustable electric stroke end switches (code FC2)
- Adjustable electric stroke end switches,
switching off the motor (code FC2X)
(not available with AC 3-phase motor)
- Extra switch for intermediate position (code FC)
- Rotative potentiometer 5kOhm for positioning control
(code POR5K)

NOTE: Extra limit switch and rotative potentiometer cannot be selected together

OPTIONS

- Motor mounting position on opposite side
(left-hand, code LH)
- Fixing attachment turned at 90° (code RPT 90)

PERFORMANCES with AC 3-phase 50 Hz 230/400 V or 1-phase 50 Hz 230 V motor

Ball screw BS 16 x 5				
RATIO	0.09 kW - 4 pole motor		0.12 kW - 2 pole motor	
	LOAD [N]	SPEED [mm/s]	LOAD [N]	SPEED [mm/s]
RH1	2160	29	1480	58
RV1	3260	19	2300	37
RN1	5990	9.5	4170	19
RL1	7000	4.5	7000	9.5

Self-locking conditions

Self-locking condition is achievable with brake motor only.

Information about statically self-locking conditions with pull or push load on page 68.

ORDERING CODE EXAMPLE

CLB 27	RL1	C200	CA 400 V	FC2	POR 5K				
Actuator	Selected ratio	Required stroke	Motor	Stroke end switches	Accessories			Options	

OVERALL DIMENSIONS

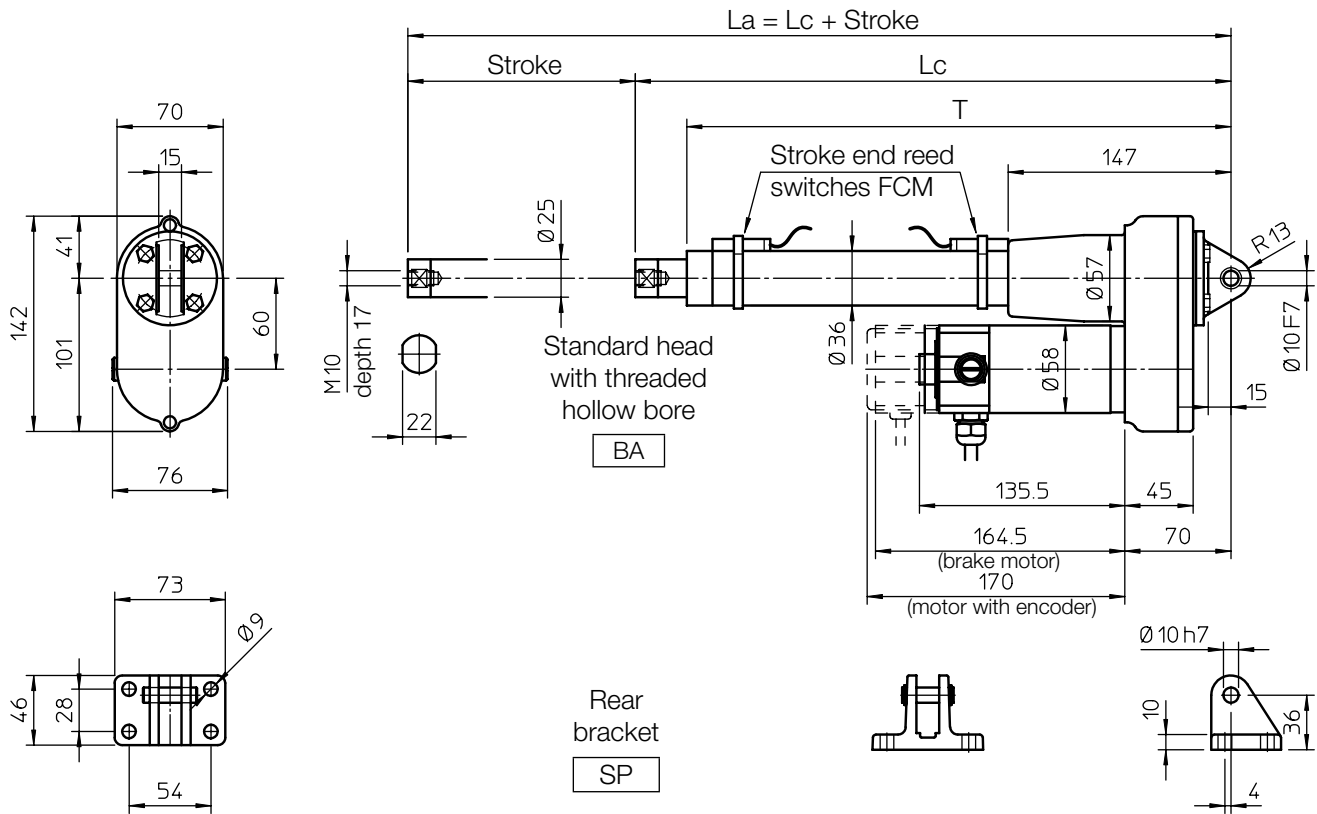

Length [mm]	Actuator
Lc	281 + Stroke
T	249 + Stroke

STROKE [mm]	LENGTH		T [mm]	MASS [Kg]	
	Lc [mm]	La [mm]		standard motor	brake motor
100	381	481	349	3.7	4.2
200	481	681	449	4.0	4.5
300	581	881	549	4.3	4.8
400	681	1081	649	4.7	5.2
500	781	1281	749	5.0	5.5

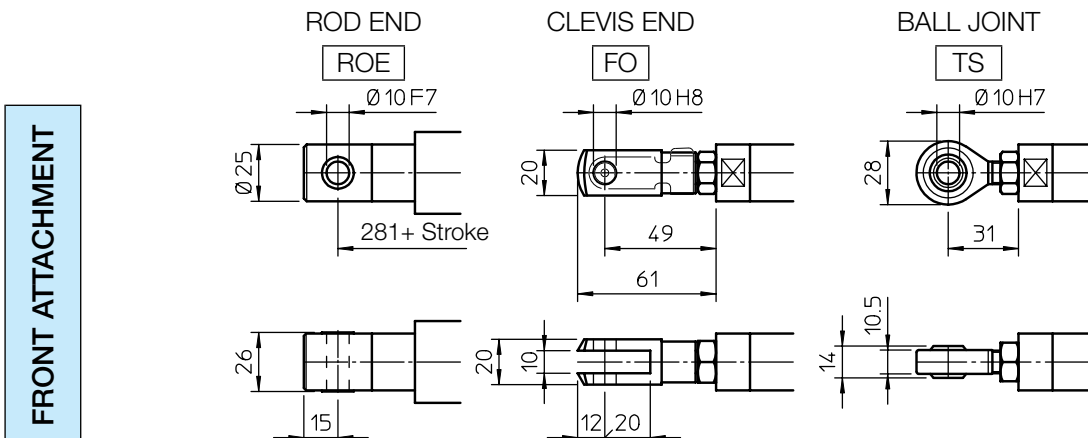

PERFORMANCES AND FEATURES

- Push-Pull load up to 420 N
- Linear speed up to 500 mm/s
- Standard stroke lengths:
100, 200, 300, 400, 500 mm
(for different / longer stroke lengths please contact us)
- Ball screw BS 14 x 5 or BS 14 x 10
(technical details on page 66)
- Aluminium alloy housing and rear attachment with bronze bush
- Anodized aluminium outer tube
- Chrome-plated steel push rod – tolerance f7
- Standard head BA or rod end ROE in stainless steel AISI 303 with bronze bush
- 12 or 24 V DC motor
(motor features details on page 69)
- Duty cycle with max load:
100% over 10 min at (-10 ... +40) °C
- Standard protection IP 54
- Long-life lubrication, maintenance free

ACCESSORIES

- Different front attachments
- Stainless steel push rod (code SS)
- Rear bracket (code SP)
- Two adjustable stroke end reed switches (code FCM)
- Extra switch for intermediate position
- Bi-directional incremental encoder, 100 ppr with zero set pulse, Push-Pull, 8÷24 Vcc (code EH38)
(encoder features details on page 75)

OPTIONS

- Fixing attachment turned at 90° (code RPT 90)

PERFORMANCES with 24 V DC motor

(Performances with 12 V DC motor: same load, linear speed 10 % less, electrical consumption 2 times more)

Ball screw BS 14 x 5			
RATIO	LOAD [N]	SPEED [mm/s]	CURRENT [A]
RV1	210	250	4
RN1	420	125	4

Ball screw BS 14 x 10			
RATIO	LOAD [N]	SPEED [mm/s]	CURRENT [A]
RV2	110	500	4
RN2	220	250	4

Self-locking conditions

Self-locking condition is achievable with brake motor only.

Information about statically self-locking conditions with pull or push load on page 68.

ORDERING CODE EXAMPLE

UBA 0	RN1	C200	CC 24 V	FCM					
Actuator	Selected ratio	Required stroke	Motor	Stroke end switches	Accessories			Options	

12.1 Ball screws

Rolled ball screw, tolerance class IT7.

Screws material: steel 42 CrMo 4 (UNI EN 10083-1) induction hardening treatment for surface hardness 58÷61 HRc

Nuts material: steel 18 NiCrMo 5 (UNI EN 10084) hardened and ground, surface hardness 58÷61 HRc, with balls surface microfinishing.

Standard axial backlash between screw and nut lower than 0.1 mm.

Executions with zero backlash or preloaded available on request.

Rolled ball screws and ball nuts are completely made in Italy, in-house manufactured by Servomech SpA S.U, Bologna.

Actuator	Ball screw	Ball diameter [mm]	Nr of ball circuits	Dynamic load C_a [N]	Static load C_{0a} [N]
BSA 08	BS 14 × 5	3.175	2	4 900	6 200
BSA 10	BS 14 × 5	3.175	2	4 900	6 200
BSA 11	BS 14 × 10	3.175	2	5 300	6 900
CLB 25	BS 14 × 5	3.175	2	4 900	6 200
	BS 14 × 10	3.175	2	5 300	6 900
CLB 27	BS 16 × 5	3.175	3	7 800	11 400
BSA 12	BS 20 × 5	3.175	3	9 100	15 400
UBA 0	BS 14 × 5	3.175	2	4 900	6 200
	BS 14 × 10	3.175	2	5 300	6 900

Static and dynamic load according to norm ISO 3408 and DIN 69051

Ball screws LOAD - LIFETIME diagram

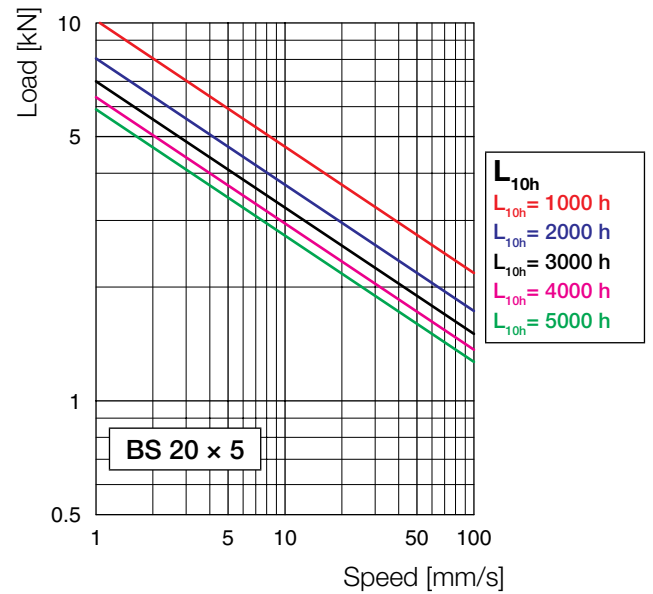
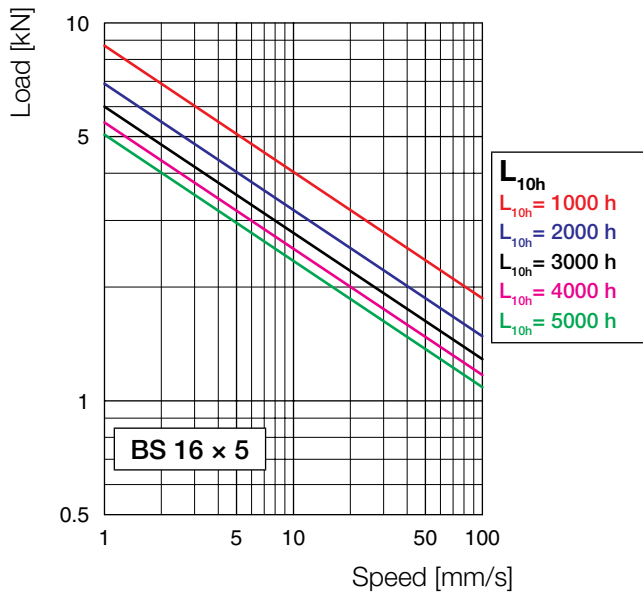
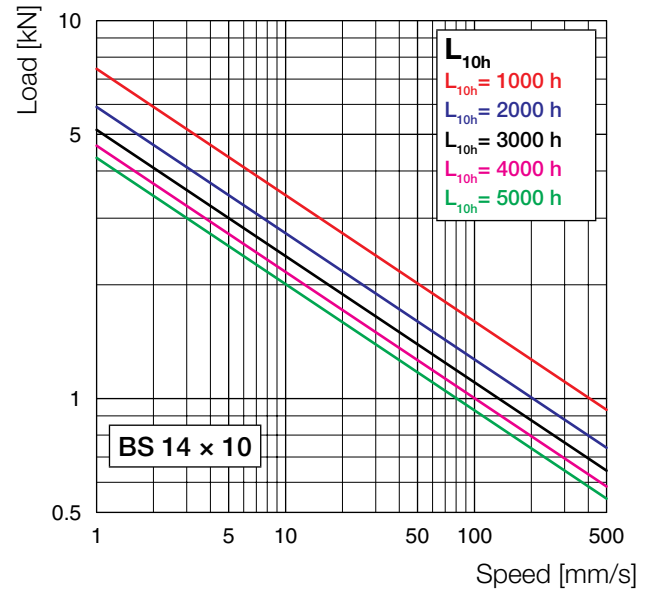
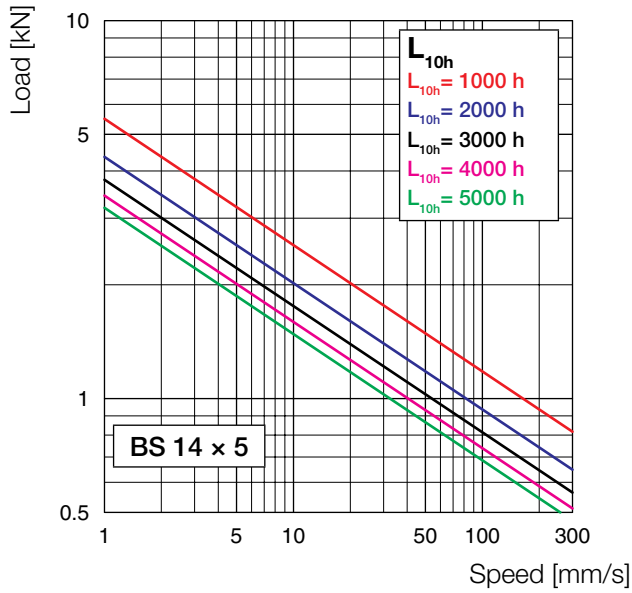

12.2 Static and Dynamic Self-locking Conditions

A linear actuator is in self-locking condition when:

- A push or pull load applied on a not running linear actuator does not start the linear movement (**statically self-locking**).
- Switching off the motor power supply of a running linear actuator, with push or pull load, the movement stops (**dynamically self-locking**).

Self-locking conditions are described in the following situations:

1. Totally static self-locking

Not running actuator, no load vibration.

A push or pull load (up to the maximum permissible) applied on the actuator does not start the linear movement: 1-start acme screw linear actuators.

2. Partially static self-locking

Not running actuator, no load vibration.

- a push or pull load (up to 70% of the maximum permissible) applied on the actuator does not start the linear movement: 2-starts acme screw linear actuators, ratios RL and RN.
- a push or pull load (up to 50% of the maximum permissible) applied on the actuator does not start the linear movement: 2-starts acme screw linear actuators, ratios RV and RH.
- a push or pull load (up to 30% of the maximum permissible) applied on the actuator does not start the linear movement: 3-starts acme screw linear actuators.

NOTE: for loads higher than the stated ones we suggest to use a brakemotor.

3. Static back-driving

Ball screw actuators are basically static back-driving even with applied load values lower than 20% of the maximum value allowed.

Therefore, we recommend to use a brakemotor.

For all uncertain self-locking conditions, both static and dynamic, please contact our Technical Dpt.

Stopping accuracy

Switching off the motor power supply, the actuator stopping depends on the following factors:

- actuator efficiency and linear speed;
- motor inertia;
- load inertia.

It is important to evaluate the correlation of all these factors to verify the need of a electric braking and, therefore, a load deceleration ramp and/or a brakemotor.

Generally, acme screw linear actuators working at a linear speed up to 15÷20 mm/s do not require auxiliary braking devices. Under high loads in the moving direction or when stopping accuracy and repeatability are required, brakemotor is recommended.

The brake is not available on actuators that fit small DC motors without interchangeable brushes (see page 69). In such cases the stopping accuracy and the static back driving should be improved by our electronic dynamic braking device (see page 77).

For any doubts concerning your application, we recommend you to contact our Technical Dpt. for further proper evaluations.

12. GENERAL FEATURES

12.3 DC MOTORS

Motors with interchangeable brushes (actuators ATL 10, UAL 0, BSA 10, BSA 11, UBA 0, CLB 25, CLB 27)

Permanent magnet DC motors, without fan, available with or without brake.

Long-life brushes, easy to replace.

Bipolar power supply cable 2 x 1 mm², 1.5 m length. Motor weight: 1.3 kg.

Output power	70 W		Rated speed	3000 rpm	
Rated current	3.7 A (24 V)	8.4 A (12 V)	Rated torque	0.22 Nm	
Peak current	18 A (24 V)	30 A (12 V)	Peak torque	1.1 Nm	
Resistance	0.85 Ohm (24 V)	0.23 Ohm (12 V)	Inductance	1.34 mH (24 V)	0.36 mH (12 V)
Protection class	IP 54		Insulation class	F	

MOTOR BRAKE: Normally closed holding brake activated by DC electromagnet available on request.

Brake separately wired with bipolar cable 2 x 1 mm², 1 m length.

Motor with brake total weight: 1.8 kg.

Power supply: 0.4 A a 24 V; 0.85 A a 12 V	Braking torque: 0.5 Nm
---	------------------------

WARNING! The motor brake is normally closed; to open it, a constant rated voltage power supply is required. With lower voltage, the brake does not open.

Motors with non-interchangeable brushes (linear actuators LMR, ATL, CLA, LMP, LMI Series)

Permanent magnet DC motors, without fan.

The brake is not available; the brushes are not interchangeable.

Standard motors winding has insulation class B.

These motors have open enclosures: the actuator is fitted with proper motor outer protections which allow to reach motor Protection Class IP 65.

The performance diagrams concerning actuators with DC motor stated in this catalogue, show the input power variation depending on the load variation.

This allows to select power supply / drivers properly.

Motor wires connection – Actuator push rod travelling direction

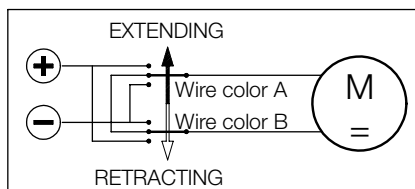

Actuator with DC motor, RIGHT-HAND mounting	LMR 01	LMR 03	ATL 02	ATL 05	ATL 08	ATL 12	CLA 20	CLA 25
Wire color A	red	red	brown	brown	brown	red	brown	brown
Wire color B	black	black	blue	blue	blue	blue	blue	blue

Actuator with DC motor, LEFT-HAND mounting	LMR 01	LMR 03	ATL 02	ATL 05	ATL 08	ATL 12	CLA 20	CLA 25
Wire color A	red	red	blue	blue	blue	blue	blue	blue
Wire color B	black	brown	brown	brown	brown	red	brown	brown

12.4 AC MOTOR							
Actuator	Motor	Power kW	N° of poles	Input voltage Vca	Frequency Hz	Rated current A	Capacitor uF
ATL 02	AC 3-phase	0.06	2	230/400	50	0,7-0,4	-
	AC 1-phase	0.06		230		0.68	5
ATL 10	AC 3-phase	0.12	2	230/400	50	0,81-0,46	-
		0.09	4			0,8-0,45	-
	AC 1-phase	0.12	2	230		2.6	12.5
		0.09	4			1.6	12.5
ATL 12	AC 3-phase	0.25	2	230/400	50	1,3-0,75	-
		0.18	4			1,1-0,66	-
	AC 1-phase	0.25	2	230		2.1	20
		0.18	4			1.9	16
CLA 20	AC 3-phase	0.06	2	230/400	50	0,7-0,4	-
	AC 1-phase	0.06		230		0.68	5
CLA 25 CLA 25S CLA 25M	AC 3-phase	0.12	2	230/400	50	0,81-0,46	-
		0.09	4			0,8-0,45	-
	AC 1-phase	0.12	2	230		2.6	12.5
		0.09	4			1.6	12.5
CLA 28 CLA 28 T	AC 3-phase	0.06	2	230/400	50	0,7-0,4	-
	AC 1-phase	0.06		230		0.68	5
BSA 10 BSA 11	AC 3-phase	0.12	2	230/400	50	0,81-0,46	-
		0.09	4			0,8-0,45	-
	AC 1-phase	0.12	2	230		2.6	12.5
		0.09	4			1.6	12.5
BSA 12	AC 3-phase	0.25	2	230/400	50	1,3-0,75	-
		0.18	4			1,17-0,66	-
	AC 1-phase	0.25	2	230		2.1	20
		0.18	4			1.9	16
CLB 25 CLB 27	AC 3-phase	0.12	2	230/400	50	0,81-0,46	-
		0.09	4			0,8-0,45	-
	AC 1-phase	0.12	2	230		2.6	12.5
		0.09	4			1.6	12.5

12.4 AC MOTOR							
Insulation class (1)	Motor protection class (1)	Fan	Brake	Brake coil power supply (2) (3)	Brake rated current A	Braking torque Nm	Brake protection class
F	IP 55	Not available	Not available	-	-	-	-
F	IP 55	Standard	On request	DC powered by rectifier	0.05	1.7	IP 44
F	IP 55	Standard	On request	DC powered by rectifier	0.09	4	IP 44
F	IP 55	Not available	Not available	-	-	-	-
F	IP 55	Standard	On request	DC powered by rectifier	0.05	1.7	IP 44
F	IP 55	Standard	Not available	-	-	-	-
F	IP 55	Standard	On request	DC powered by rectifier	0.05	1.7	IP 44
F	IP 55	Standard	On request	DC powered by rectifier	0.09	4	IP 44
F	IP 55	Standard	On request	DC powered by rectifier	0.05	1.7	IP 44

(1) Higher insulation and protection classes available on request.

(2) Normally closed activated by DC electromagnet.
The electromagnet is powered by a 1-phase rectifier fitted in the terminal box.

(3) Motors with separately powered brake available on request.
This solution shall be used for applications with frequency inverter.

GENERAL NOTE

In case the linear actuator is used in an application where the stroke end switches must be connected to PLC or PC, we suggest to make the connection with a galvanic separation circuit.

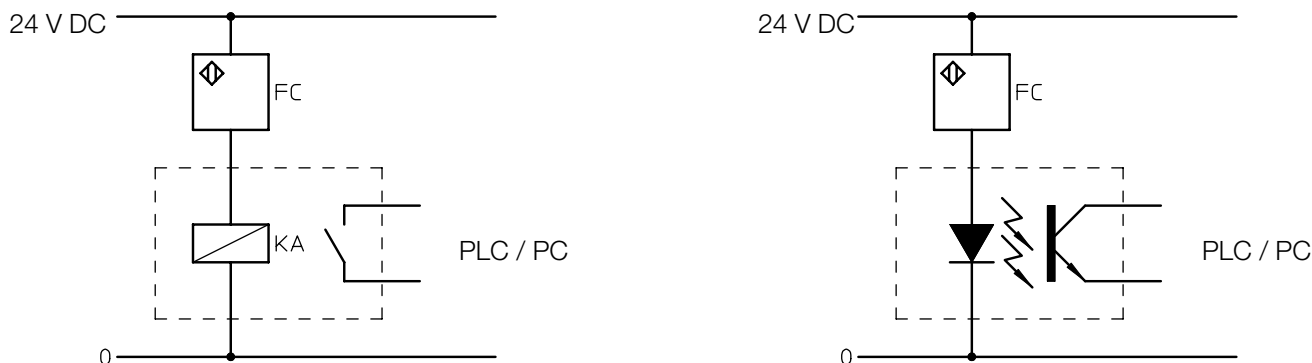

13.1 Magnetic stroke end switches (reed) FCM (linear actuators ATL, BSA, UAL, UBA Series, LMI 02 and LMP 03)

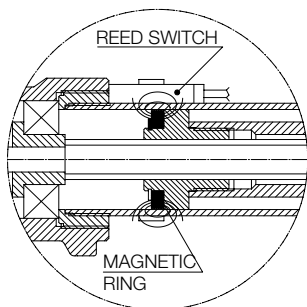

The magnetic field of the ring fixed on the nut activates the reed contact of the switch locked on the protective tube with a clamp.

The position of the switches along the tube is easily adjustable.

The switches used to determine any intermediate position (between L_c and L_a) will switch over in two different positions, depending on the push rod motion direction (extending or retracting).

WARNING! The magnetic reed-switches can work only if connected to a wiring control circuit in order to activate the electric relay. Do not connect them in series between the power supply and the electric motor!

REED CONTACT RATED VALUE

	DC	AC
Rated voltage	(3 ... 130) V	(3 ... 130) V
Max. commutable power	20 W	20 VA
Max. commutable current	300 mA (resistive load)	
Max. inductive load	3 W	

Standard: NC switch (normally closed contact) equipped with signalling LEDs and protective varistor against voltage peaks.

Standard cable length 2 m; wires 2 × 0.75 mm²

Different configurations available on request: NO (normally open); CS (exchanging contact).

For more information please contact our Technical Dpt.

13.2 Electric stroke end switches FCE (actuators ATL 10, ATL 12, BSA 10, BSA 12)

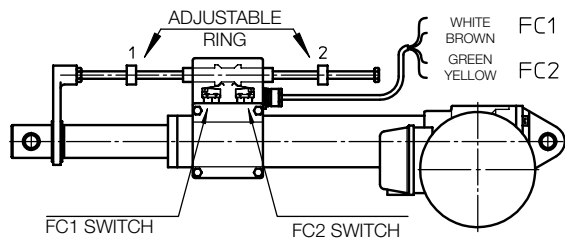

Two electric switches, installed inside a sealed plastic box, are activated by two adjustable rings through a shaft collar.

Standard switches are wired on the NC contact, cable length 1.5 m; wires 4 × 0.75 mm²

On request, they can be wired on the NO contact or on the switch-over contact CS (for available configurations please contact our Technical Dpt).

Min retracted length L_c is adjusted by ring 1. FC1 switch is connected with the WHITE and the BROWN cables.

Max extended length L_a is adjusted by ring 2. FC2 switch is connected with the YELLOW and the GREEN cables.

The position of the brass rings along the stainless steel supporting rod is easily adjustable.

CONTACT RATED VALUE

Voltage	Max current	
	Resistive load	Inductive load
250 Vac	5 A	3 A
30 Vdc	5 A	0.1 A
125 Vdc	1.4 A	-

WARNING! The electric reed switches can work only if connected to a wiring control circuit in order to activate the electric relay. Do not connect them in series between the power supply and the electric motor!

13.3 Electric stroke end switches FC (linear actuators LMR Series)

Each of the two micro-switches is fitted in a slot with a cam for switches commutation. A screw allows to lock the assembly in the desired position, adjusting in this way the switching position. The nut with suitable shape makes the cams rotate, so to activate the switches. This cam-operated device provides a stable and self-keeping commutation of the switches. The **MIN. RETRACTED LENGTH L_c** of the actuator is adjusted and controlled by switch FC1. The **MAX. EXTENDED LENGTH L_a** of the actuator is adjusted and controlled by switch FC2.

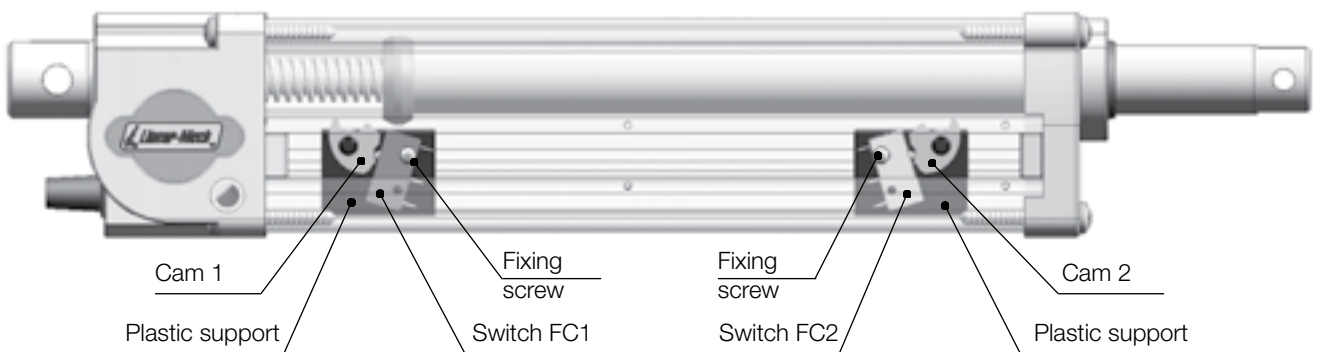

Following pictures show the switching sequence for switch FC2.

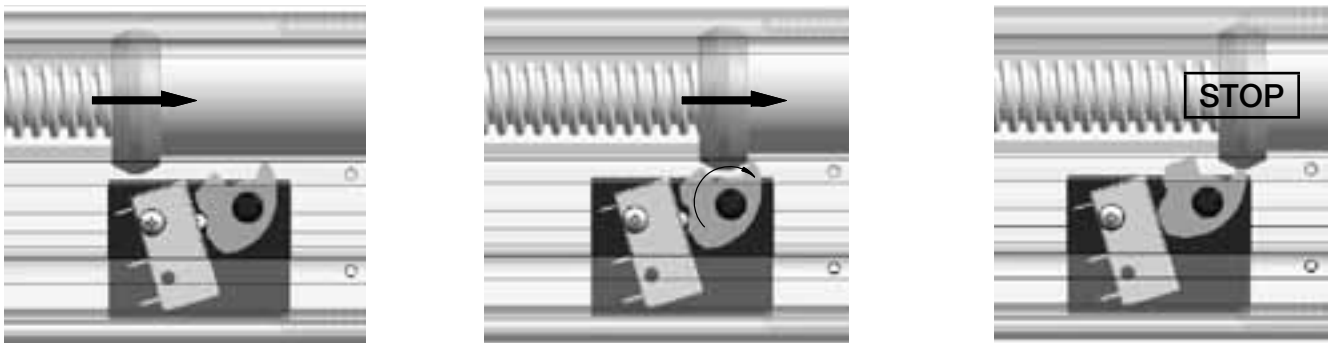

Standard switches have silver-plated contacts, max. current 12 A with resistive load - 6 A with inductive load. Switches with gold-plated contacts, very low contact resistance for low working voltage (if connected to PLC or PC), max. current 0.1 A, available on request.

STANDARD switch connection

Code **FC2**: two electric cam-operated switches, wired on contact NC (to be connected into the external control circuit). On request, the switches can be wired on the contact NO or on switch-over contact CS. Code **FC2X**: two electric cam-operated switches, internally wired between power supply and electric motor, in order to switch off the power supply directly, without relays.

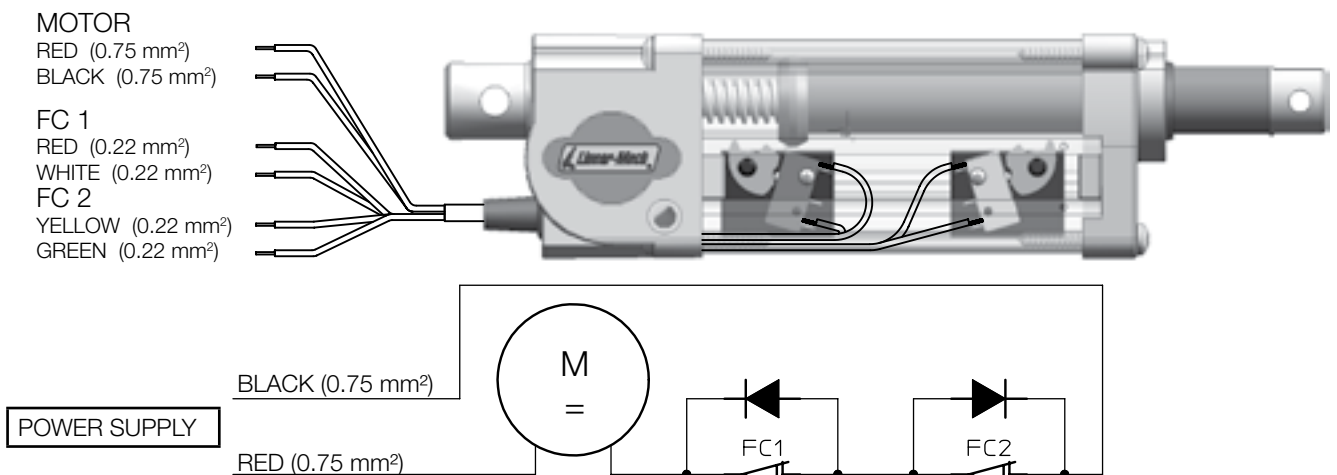

13.4 Electric cam-operated stroke end switches (linear actuators CLA and CLB Series)

Code **FC2**: two electric cam-operated switches, wired on contact NC (to be connected into the external control circuit). On request, the switches can be wired on the contact NO or on the switch-over contact CS. (For available configurations please contact our Technical Dpt).

Code **FC2X**: two electric cam-operated switches, internally wired between power supply and electric motor, in order to switch off the power supply directly, without relays. Available for actuators with Dc or AC 1-phase motor.

Code **FC2 + FC** or **FC2X + FC**: Stroke end switches FC2 or FC2X with a third switch for any intermediate position. The third switch can be wired on contact NC or NO on request. (For different configurations please contact our Technical Dpt).

SWITCH RATED VALUES		
Voltage	Max current	
	Resistive load	Inductive load
250 Vac	21 A	12 A
30 Vdc	14 A	12 A
125 Vdc	0.8 A	0.6 A

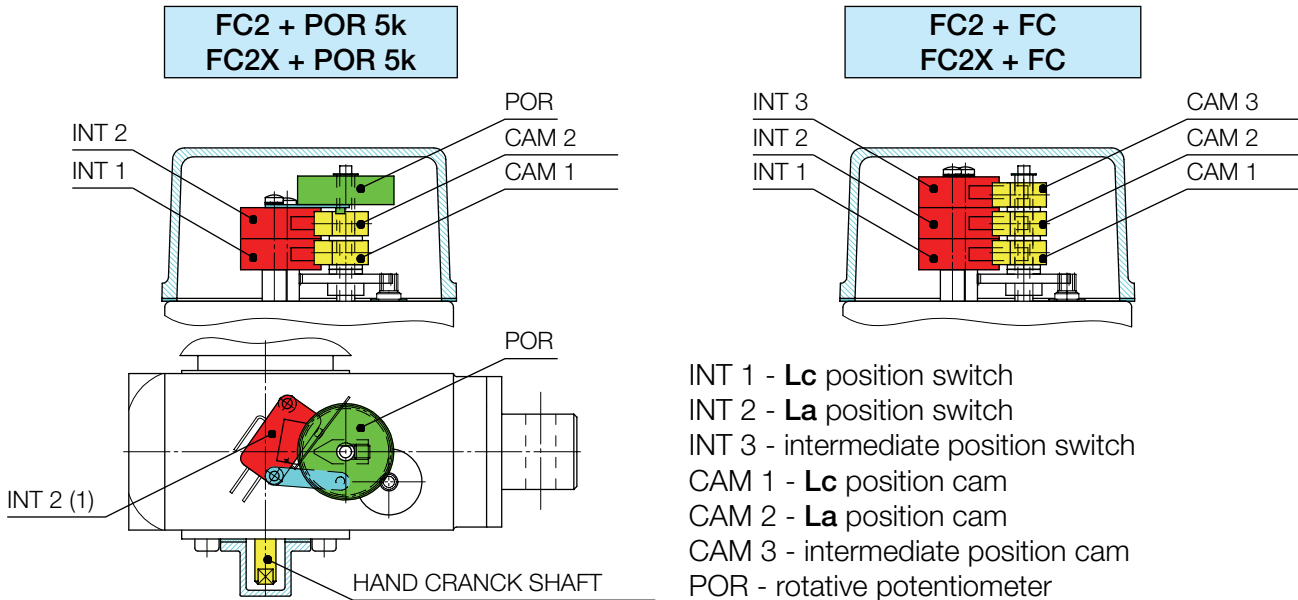

Lc = actuator retracted length, **La = Lc + Stroke** – actuator extended length

13.4 Rotative potentiometer for positioning control (linear actuators CLA and CLB Series)

Code **POR 5k**: rotative potentiometer, single turn (340°), 5 kOhm ± 20 %, linearity ± 2 %

The rotative potentiometer is an absolute transducer, whose output signal is proportional to the current position of the actuator push rod. Analogic output signal.

Standard cable: 4 x 0.25 mm² + shield, 1.5 m length (for different configurations please contact us).

POR 5k standard wiring diagram:

POR Power supply: 0 V dc

Reference signal: ZERO

Reference signal: RETURN

POR Power supply: + V cc

SHIELD

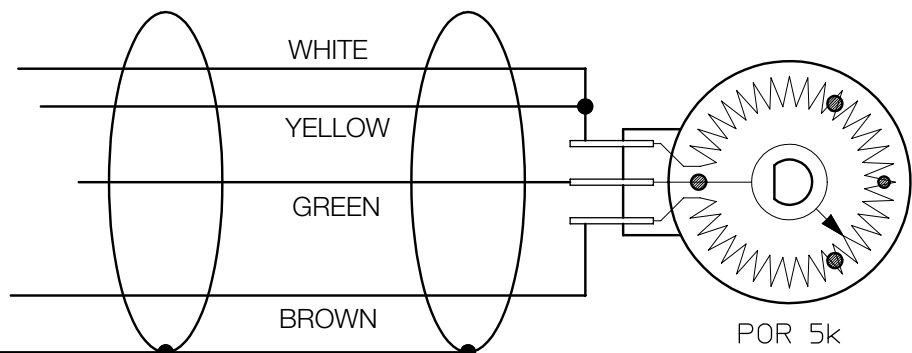

13.5 Encoder GI (linear actuators LMR 01, LMR02, LMR 03 and LMP03)

Hall effect, bi-directional, incremental encoder

Output configuration: PUSH-PULL

Code GI 21: 2 output channels, 1 pulse per revolution

Code GI 24: 2 output channels, 4 pulses per revolution

Cable length: as motor cable

Protected against polarity inversion

Protected against any incorrect output connection

NOTE: For conductive cables colour, please refer to the wiring diagram in the “Installation Instructions” supplied with the product.

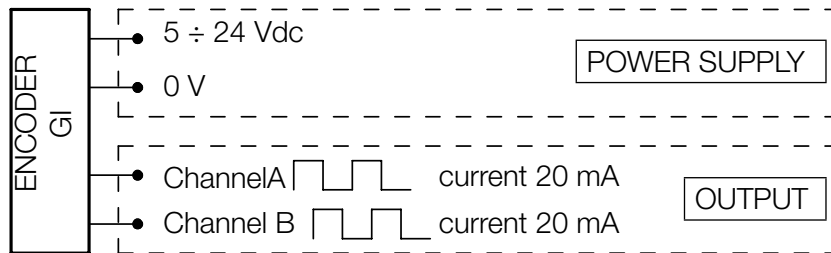

13.6 Encoder EH38 (linear actuators ATL 10, UAL 0, BSA 10, UBA 0)

Bi-directional, incremental, optical encoder

Output configuration: PUSH-PULL

Code EH38: 2 output channels, 100 pulses per revolution, with zero set pulse

Cable length: 1.3 m

Protected against short circuit

Protected against polarity inversion

Protected against any incorrect output connection

Input voltage: 8÷24 Vcc

No load power consumption: 100 mA

Max. commutable current: 50 mA per channel

NOTE: Safety clutch FS cannot be used with rotative encoder (the position reference would be lost due to its slipping).

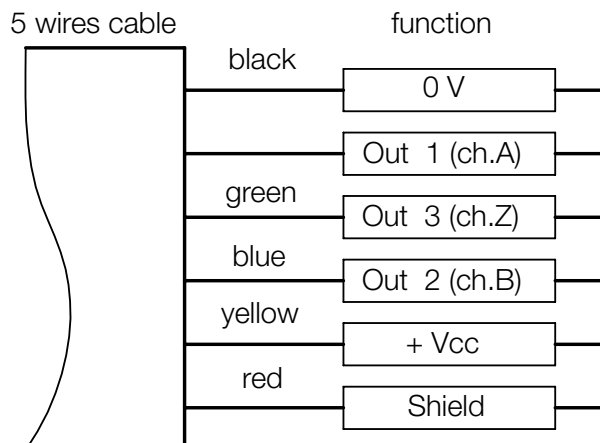

14.1 LME 01 - Electronic overload protection

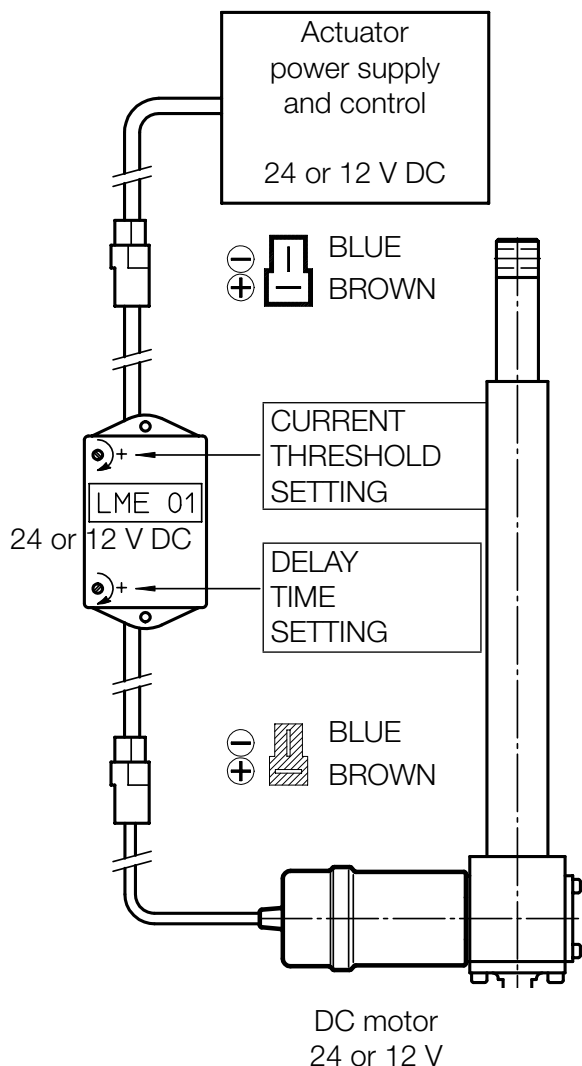

LME 01 is an electronic device that protects DC motors against current overloads due to a persistent dynamic overload applied on the actuator.

The electronic protection LME 01 is suitable for all LINEARMECH actuators with DC motor.

LME 01 is connected between electric motor and power supply.

An electronic circuit inside monitors the input current and, as this reaches the preset threshold value, LME 01 cuts it off.

A trimmer enables the threshold current value adjustment within a continuous range.

Protection intervention can be delayed to allow the motor start. This delay time can be set within a continuous range with a trimmer.

Turn off the power supply to reset the device.

The electronic circuit is inside a plastic box with flats for easy mounting.

TECHNICAL DATA		
Model	24 V	12 V
Supply voltage [V dc]	24	12
Output voltage [V dc]	24	12
Current threshold range [A]	2 ... 10	4 ... 20
Delay time range [s]	0 ... 1.5	
Max. duty cycle	15 % over 10 min	
Protection class	IP 30	
Box material	ABS	
Box dimensions [mm]	89 × 64 × 30	
Connection cables length: 150 mm, with fast-on connectors		

ORDERING CODE EXAMPLE

LME 01	24 V	ATL 02
	Model	Actuator connected to LME 01

14.2 LME 02 - Electronic dynamic braking

Small size DC motors fitted on many of Linearmech actuators are not available with mechanical brake (operation and/or static brake). There is no accuracy on actuator's stop position without the mechanical brake on the motor, when switching off the power on motor itself. The uncertainty depends on the speed, the load inertia and other factors such as actuator's performances and efficiency.

Thanks to the new Linearmech **LME 02** control is possible to: power supply the actuator with 12 or 24Vdc; manage electromechanical limit switches (FCE, FC2) or magnetic limit sensors (FCM); dynamic braking the actuator when the motor is switched off, by closing in short circuit the motor (slowing down the motor rotor and the load).

When the motor is switched off, it is closed in short circuit. This condition, with the actuator in still position, increases the self-locking capacity of the actuator. This is an help to hold the position and the load even when the ratio and the pitch of linear actuator's screw are non self-locking. When the "Electronic dynamic braking" does not ensure the desired accuracy, it is recommended to use different solutions with brake motors. The "Electronic dynamic braking" is more effective on low speed linear actuators. The effectiveness lowers while speed and efficiency increase (acme screws with more starts or ball screws).

Please contact our Technical Dept. for more details.

The LME 02 control device can be connected to the actuator according to the following wiring diagrams.

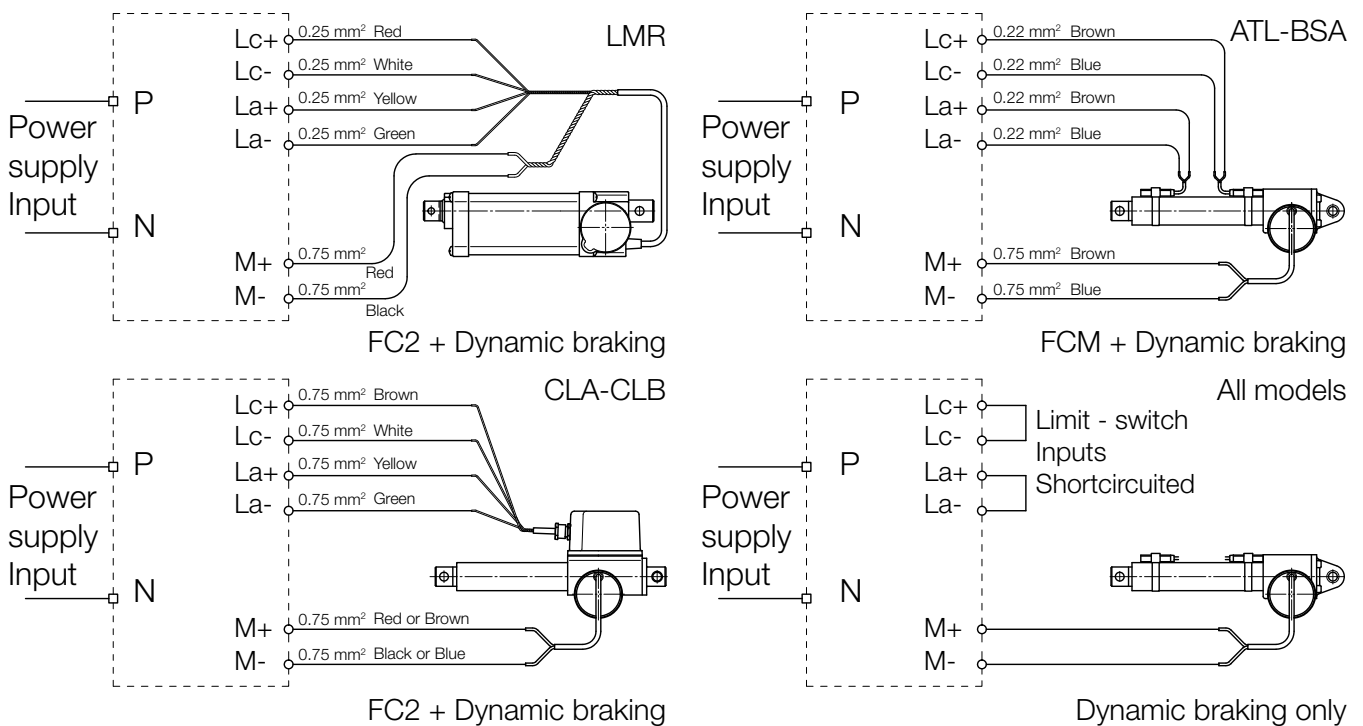

WORKING MODE

LME 02 device must be fitted between power supply and actuator motor according to the above wiring diagrams. Actuator push rod moves forward (FW) or reverse (REV), depending on power supply polarization on LME02 input pins.

Input pin "P" -> + Vdc	FW
Input pin "N" -> 0 Vdc	movement
Input pin "P" -> 0 Vdc	REV
Input pin "N" -> + Vdc	movement

Powering on this device the actuator push rod moves. The actuator stops when power supply is switched off or limit switches positions are reached (same running conditions as per actuators with FC2X but with the advantage that switches do not cut off the motor current). In both conditions, the "Electronic dynamic braking" is active. The braking is held even without power supply.

The switch FC2X (see pages 73 and 74) is an internal wiring between power supply and electric motor in order to switch off the power supply directly, without relays, when the limit positions are reached.

TECHNICAL FEATURES	Power supply	12 or 24 Vdc	Peak current	15 A
	Nominal current	10 A	Intervention time	20 ms

Transport and Handling

Linearmech electromechanical actuators are very robust products, since they are structurally built with metallic components; nevertheless, motors provided with their protections, stroke end switches and encoders require a particular care and attention in packaging and during transport and handling.

Therefore, we recommend to handle the actuators using their supporting points, such as the housing, and not the stroke end devices or motor. Finally, we recommend not to bang the actuators one against the other or against machine surfaces. The electric components of stroke end switches, encoders and motors must be handled with care!

Storage

During storage, electro-mechanical actuators shall be protected against atmospheric agents and dust or other pollutants settling on the push rod.

We recommend to store the products in environment temperature range within (-10 ... +40) °C

Installation

Linear actuators must be installed to work with push or pull axial load only.

Lateral and radial loads are not permissible.

The front and rear fixing attachments must be aligned!

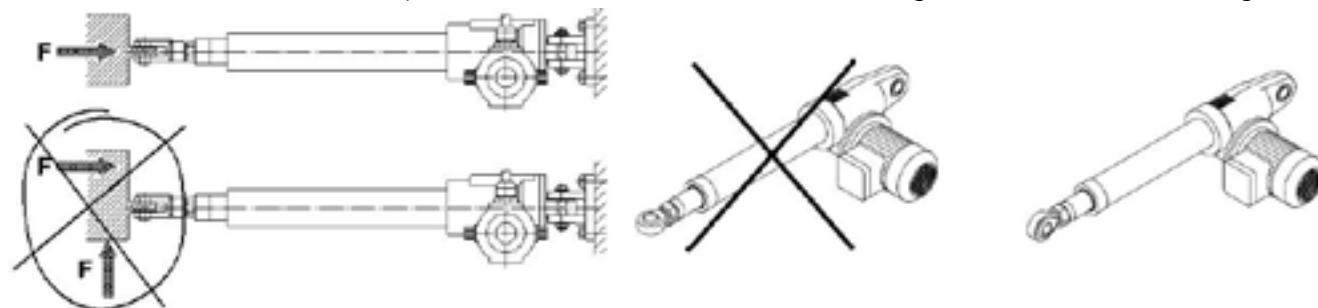

Ball joint front attachment is recommended in case the alignment of front and rear fixing points cannot be guaranteed. An incorrect installation can cause loss of power, malfunctioning, noise and lubricant leakage.

The actuator minimum retracted length (L_c) and maximum extended length (L_a) are the operation limits.

Make sure that the application does not require a stroke length longer than the one fixed by these limits.

The use of the actuator exceeding its max. extended length (L_a) and min. retracted length (L_c) and the provided internal protections, cause collision against the mechanical stops with consequent possible damage of screw and bronze nut.

Commissioning and use

Linearmech linear actuators are supplied with long-life lubricant and therefore maintenance-free.

Before activating the actuator, the following checks must be carried out:

- Verify the motor shaft turning direction (motor wiring connection) and the related push rod travelling direction.

Wires connection related to the push rod travelling direction is shown on page 69, in the section concerning electric motors wires connection.

- Verify the stroke end switches position: the minimum limit L_c nor the maximum limit L_a can be exceeded.
- Make sure that the electric motor and the stroke end switches are connected correctly and that the right voltage is used.

During commissioning and tests, do not exceed the working conditions stated for each actuator as allowed duty cycle in % over 10 minutes.

Any misuse can cause over-heating and unintentional premature damaging.

For further explanations and in case of doubts please contact Linearmech S.r.l.

The compliance failure of any recommended and suggested instructions for handling, storage, installation, commissioning and use of the product implies the immediate lost of warranty.