



LINEAR ACTUATORS

ATL 100 – ATL 125

BSA 100 – BSA 125

Installation, operation and maintenance manual

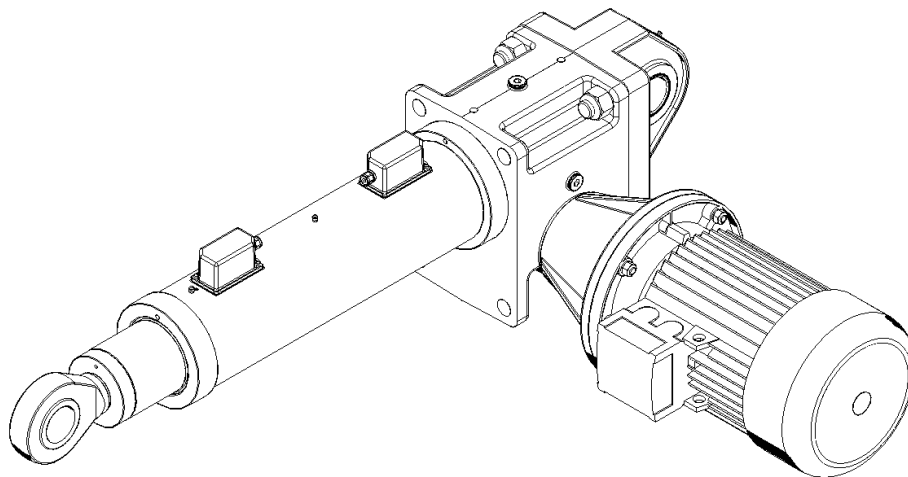
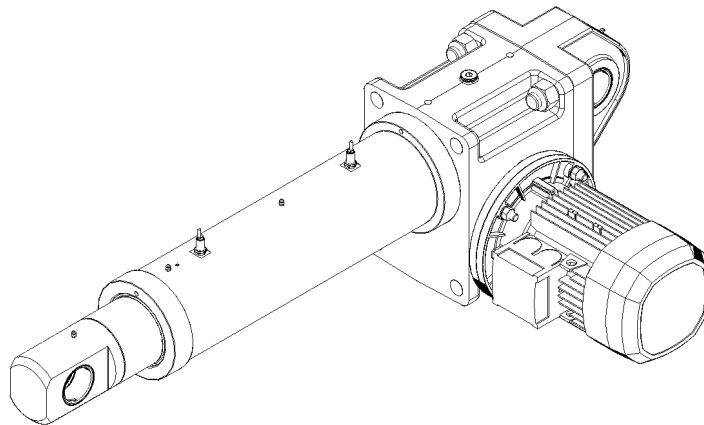

Publication: 02.100-125.E - Rev. 01 Date (M/Y) 01/24

Servomech S.p.A. Via M. Calari, 1 - 40011 Anzola dell'Emilia (BO) - ITALY

Ph: + 39 051 6501711 Fax: + 39 051 734574

www.servomech.com info@servomech.com



Read this manual before installing, operating or maintaining this actuator. Failure to follow safety precautions and instructions could cause actuator failure and result in serious injury, death or property damage.

This manual provides important information on how to work with the actuator safely and efficiently. The manual is part of the device, must always be kept in the device's direct proximity and should be available for personnel to read at any time. Failure to comply with the installation, use and maintenance instructions indicated in this manual will result in immediate termination of the warranty conditions of the actuator and completely relieve Servomech S.p.A. from any liability for damage caused to persons and / or property.

Servomech S.p.A. it does not assume direct or indirect responsibility for an improper use of the actuator, not respecting the performances of the actuator declared in the catalogs.

The manufacturer will not be liable for damage to the actuator or the equipment into which the actuator has been installed resulting from:

- disregarding this manual
- unintended use
- employment of untrained personnel
- unauthorized conversions
- technical modifications
- manipulation or removal of the screws on the device
- use of unapproved spare parts

The aforementioned conditions are therefore not contemplated and entail the immediate termination of the guarantee and the immediate decay of any responsibility on the part of Servomech S.p.A.

Servomech S.p.A. reserves the right to make changes to the actuators and this manual without giving any notice.

LINEAR ACTUATORS ATL/BSA 100-125

Installation, operation and maintenance manual

Contents

1	MODELS COVERED BY THIS DOCUMENT.....	4
2	IDENTIFICATION OF THE MANUFACTURER AND THE PRODUCT.....	4
2.1	Identification of the manufacturer.....	4
2.2	Description of the product.....	4
2.3	Identification of the product.....	5
3	TRASPORT AND HANDLING.....	6
4	USE RESTRICTION.....	7
4.1	Intended use.....	7
4.1.1	Use restrictions.....	7
4.1.2	Standard operating conditions.....	8
4.1.3	Thermal limit.....	8
4.2	Personnel requirements / Qualifications.....	8
5	STORAGE.....	8
6	INSTALLATION.....	9
6.1	Safety warnings.....	9
6.2	FCP inductive proximity stroke limit switches.....	10
6.3	FC electric stroke limit switches.....	11
6.4	Rotary encoder ENC.4.....	13
6.5	Rotary encoder EH53.....	13
6.6	Servomotor assembly.....	14
6.7	Electric motor wiring.....	15
6.8	Linear actuator installation.....	17
6.9	Installation of rod end fitting elements.....	18
7	COMMISSIONING AND USE.....	19
8	LUBRICATION.....	20
9	MAINTENANCE.....	21
9.1	Linear drive lubrication.....	22
9.2	Push rod guide lubrication.....	23
9.3	Rear hinge lubrication.....	23
9.4	Hinged head TF lubrication.....	24

1 MODELS COVERED BY THIS DOCUMENT

The present manual is referred to following products:

Acme screw linear actuators: ATL100 – ATL125

Ball screw linear actuators: BSA100 – BSA125

2 IDENTIFICATION OF THE MANUFACTURER AND THE PRODUCT

2.1 Identification of the manufacturer

SERVOMECH S.p.A. S.U.

Via Monaldo Calari, 1

40011 Anzola dell'Emilia (BO)

ITALY

Ph. +39 051 6501 711

Fax. +39 051 7345 74

Website: www.servomech.com

e-mail: info@servomech.com

2.2 Description of the product

For all the technical characteristics of the product (performance, features, dimensions) refer to the technical catalog.

Main actuator components:

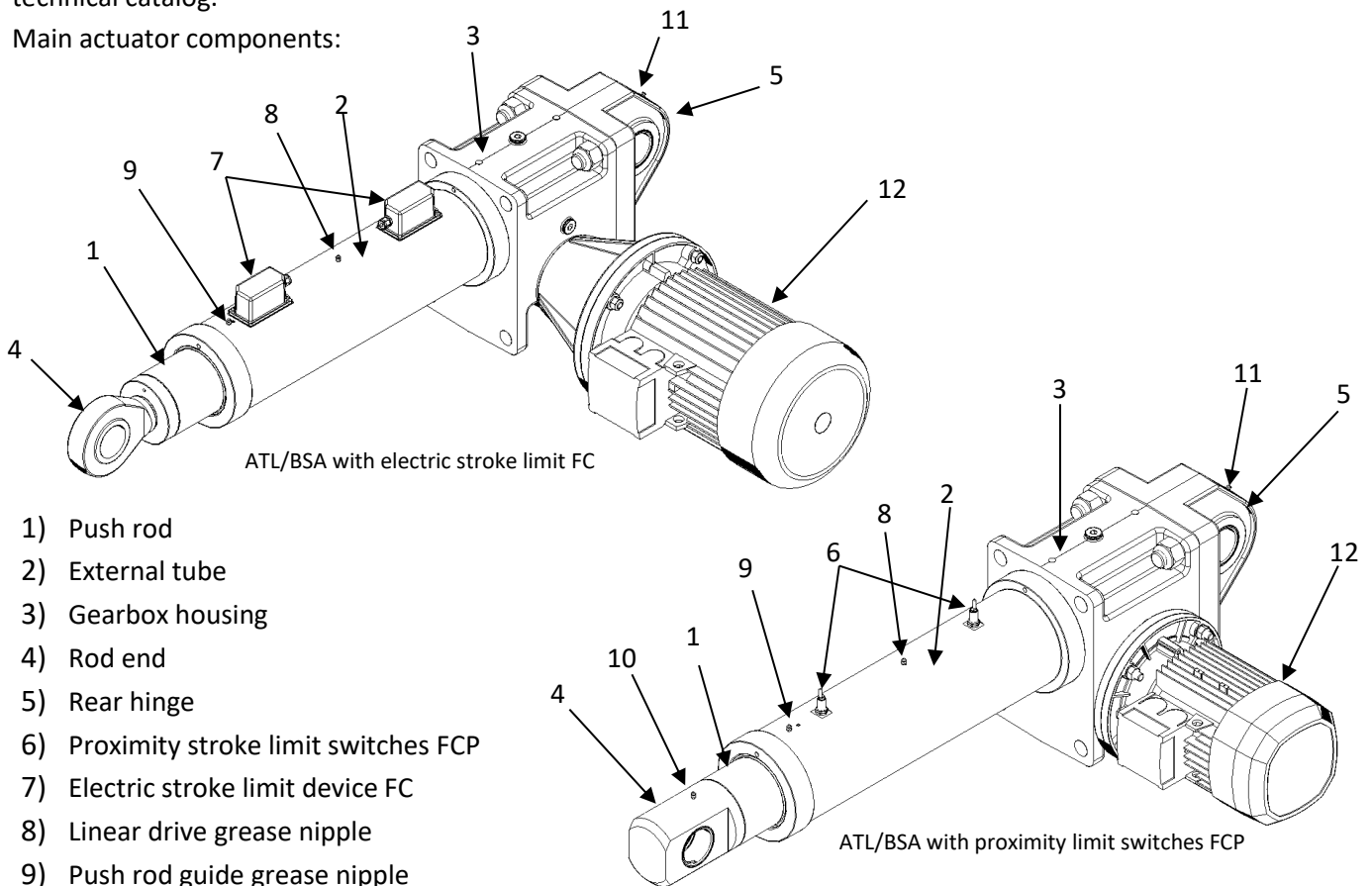

- 1) Push rod
- 2) External tube
- 3) Gearbox housing
- 4) Rod end
- 5) Rear hinge
- 6) Proximity stroke limit switches FCP
- 7) Electric stroke limit device FC
- 8) Linear drive grease nipple
- 9) Push rod guide grease nipple
- 10) Hinged head grease nipple
- 11) Rear hinge grease nipple
- 12) Electric motor

Figure 2.1 – Linear actuator components

2.3 Identification of the product

Every SERVOMECH linear actuator is provided with a nameplate, as shown below, which allows the product identification and gives technical information about the product.

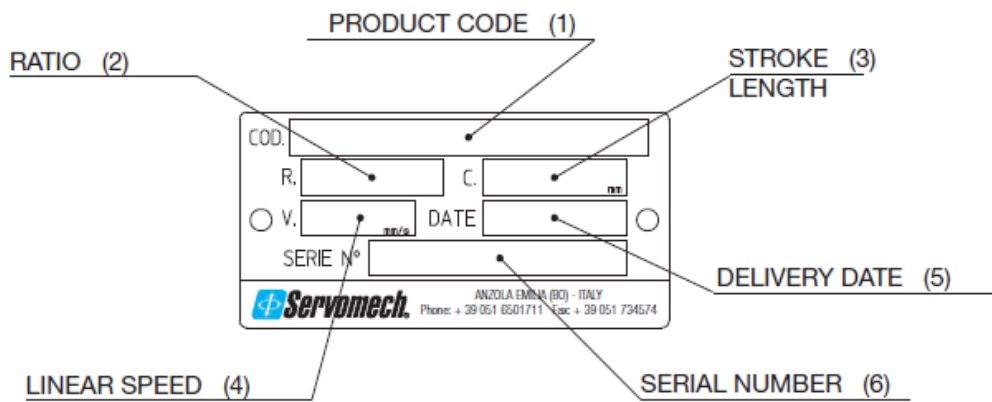

Figure 2.2 – Identification nameplate

- 1) **Product code**: is an alphanumeric code stating the type, size, ratio, version and stroke end switches of the linear actuator;
- 2) **Ratio**: is the ratio of the input drive;
- 3) **Stroke length**: is the stroke length in millimetres achievable by the actuator;
- 4) **Linear speed**: is the linear speed expressed in mm/s when the actuator is provided with electric motor; for an actuator without motor, this field is blank;
- 5) **Delivery date**: is the week/year of assembly (example: 30/13 = week 30 / year 2013) which usually coincides with the delivery date; this date is considered as reference for the warranty period;
- 6) **Serial number**: is the identification number of the actuator which identifies the exact design of the product even after a long time; the serial number is the essential reference for spare part orders.

3 TRASPORT AND HANDLING

- ⚠ It is recommended to pay attention and care during the handling and transport of linear actuators not to damage mechanical parts and / or accessories and to prevent risks for the personnel in charge of this activity.
- The packaging must be lifted and moved with care and in a safe way.
- Use only safety-inspected and suitable load hoisting equipment.
- For lifting and transporting the linear actuator, the push rod must be in retracted position.
- When transporting the product with attached motor, always provide support for the motor, or remove the motor before transporting the product.
- Lift the actuator from the housing and outer tube using suitable slings.
- DO NOT lift the actuator from the push rod and / or the motor.
- Prevent the actuator from swinging during lifting operations.
- ⚠ In the case of BSA series actuators, the ball screw inside the actuator is NOT self-locking. Never lift the linear actuator upright from the push rod as the actuators could be back driven by its own weight.

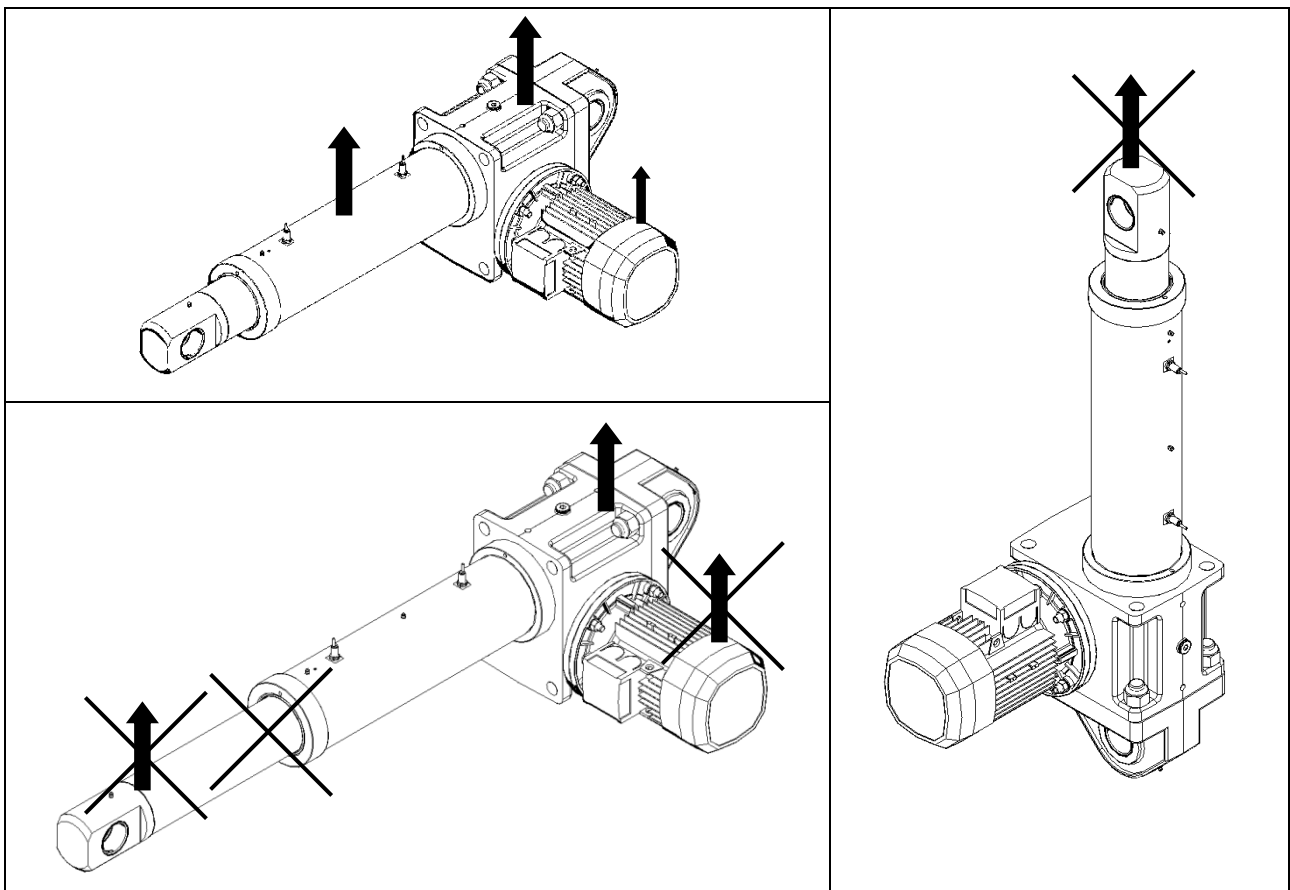

Figure 3.1 – Transport and handling

- Before hoisting the linear actuator, check the weight on the following table:

	ATL 100	ATL 125	BSA 100	BSA 125
Mass (actuator 100 mm stroke length, without motor, with lubricant) [kg]	200	400	200	400
Extra-mass for each additional 100 mm stroke length [kg]	10.5	18.5	12.5	19

In case of doubt, consult SERVOMECH S.p.A. to get the appropriate information and prevent any kind of damage!

4 USE RESTRICTION

The information contained in this chapter provides important prescriptions for operating safely during all phases of the product's life.

Not knowing or not complying with these provisions can generate dangerous situations that could cause damage to equipment and risks for the safety of persons.

4.1 *Intended use*

Actuators are used to perform very different functions within machines. It is the responsibility of the machine builder to design the application in compliance with the laws in force in the specific sector and in the field of safety, in compliance with the requirements provided in the product catalog and in this manual.

- ⚠ ACTUATORS ARE ELECTRIC AXIS, WHATEVER DRIVER OR CONTROL WILL BE USED: THE SELECTION OF THE PRODUCT AS STROKE, SPEED, TYPE OF LIMIT SWITCHES, MOTOR AND BRAKE, MUST BE DONE ACCORDING TO THE BEHAVIOR EXPECTED, IN FUNCTION OF THE TYPE OF CONTROL CHOSEN AND THE STATIC AND DYNAMIC BEHAVIOR OF THE SYSTEM IN WHICH THE ACTUATOR IS PLACED!

The actuators have been designed and built to operate mobile parts of various types, shapes and construction, in the ways and within the limits set out in the descriptions and tables of the technical data in the catalog and in this user manual.

The actuators are designed to work with a purely axial applied load.

They must be subjected to the loading and speed conditions specified in the catalog.

Modification of parts of the actuator or replacement of components with different and non-original parts is not permitted. The replacement of components with original spare parts is carried out only by Servomech S.p.A.

Any different use is to be considered improper and therefore potentially dangerous for the safety of the operators, as well as such as to void the contractual guarantee.

In the event of particular processing requirements, we recommend consulting our sales department.

Every modification must be authorized by Servomech S.p.A. with written documents.

- ⚠ ANY OTHER USE OUTSIDE THAT THAT JUST DESCRIBED IS NOT PERMITTED BY SERVOMECH S.p.A.

4.1.1 Use restrictions

Actuators can not be used for unforeseen applications.

Any utilization of this device beyond its intended purpose may lead to potentially hazardous situations.

Therefore:

- Strictly adhere to all safety precautions and instructions in this operating manual.
- Do not allow this device to be subjected to weather conditions, strong UV rays, corrosive or explosive air media as well as other aggressive media (*).
- Do not modify, retool or change the structural design or individual components of the actuator.
- Never use the device outside of the technical application and operational limits.

(*) – THE USE OF THE ACTUATOR IN ABOVE CONDITIONS MUST BE PREVIOUSLY DECLARED AND AGREED WITH SERVOMECH, SINCE A SPECIAL EQUIPMENT OF THE PRODUCT MUST BE PROVIDED.

4.1.2 Standard operating conditions

The actuator must be used in an environment whose conditions comply with the provisions of Servomech S.p.A. The works necessary for obtaining and maintaining that conditions are in charge of the owner and, where applicable, are in charge of the end user.

The actuator must be installed and used indoor only, in dry area with environmental conditions as specified below:

- Temperature range +0°C ÷ +40°C
- Relative atmospheric humidity 5% ÷ 85%
- No build up of condensation
- ⚠ THE USE OF THE ACTUATOR IN DIFFERENT CONDITIONS THAN JUST DESCRIBED MUST BE PREVIOUSLY DECLARED AND AGREED WITH SERVOMECH, SINCE A SPECIAL EQUIPMENT OF THE PRODUCT MUST BE PROVIDED.

4.1.3 Thermal limit

The actuator duty cycle permissible F_i [%] is the maximum working time expressed in percentage that the actuator can perform during the reference time period of 10 minutes, under rated load stated in the catalogue at ambient temperature 25°C, without risk of internal parts overheating.

$$F_i[\%] = \frac{\text{Max working time over 10 min}}{10 \text{ min}} \times 100$$

Linear drive	F_i [%]
Acme screw (ATL series)	30
Ball screw (BSA series)	100

- ⚠ For the proper operation of acme screw linear actuators (ATL series) do never exceed the permissible duty cycle limit.

4.2 Personnel requirements / Qualifications

This manual must be made available to the personnel in charge of installation, start up and use of the actuator. It is the responsibility of the machine builder:

- use personnel with the necessary qualifications for the installation and commissioning of the actuator;
- periodically check the qualification of the assigned personnel;
- check that the personnel in charge are aware of the contents of this manual.

5 STORAGE

- Do not store outside.
- Storage should be dry and dust-free.
- Keep away from any aggressive media.
- Protect from UV radiation.
- Avoid mechanical vibrations.
- Storage temperature: 0 to +50 °C.
- Relative atmospheric humidity: max. 95% (no build up of condensation).
- To store longer than 6 months, take care of moving the input shafts to prevent damages to sealings.
- Also check that all unpainted parts are adequately protected (oiled and /or greased) to prevent oxidation.

6 INSTALLATION

The operations described in the paragraphs of this chapter provide both electrical and mechanical connections of the actuator, as well as the execution of test motions at reduced speed and motor torque or with small displacement steps.

6.1 Safety warnings

- ⚠ MOTORS CANNOT BE CONNECTED DIRECTLY TO THE ELECTRICITY GRID. A PROPER CIRCUITS AND DEVICES FOR MOVEMENT MANAGEMENT ON BOTH DIRECTIONS IS REQUIRED. STROKE END LIMIT SWITCHES (MICROSWITCHES OR SENSORS) MUST BE CONTROLLED TO BE SURE THE LINEAR MOVEMENT OF THE ACTUATOR (DUE TO THE OPERATION OF THE MOTOR OR TO THE INERTIA OF THE MOVING PARTS) STOPS BEFORE TO REACH THE MECHANICAL STROKE END LIMITS. IN CASE THIS HAPPENS, THE ACTUATOR CAN BE LOCKED AND THE INTERNAL COMPONENTS CAN BE DAMAGED.
- ⚠ WHEN THE MOTORS MUST BE POWERED BY A CONVERTER (ELECTRIC DRIVE), THIS MUST BE CHOSEN BY QUALIFIED PERSONNEL.
- ⚠ IN CASE THERE ARE INVOLVED ELECTRONIC DRIVE AND CONTROL DEVICES ON THE ACTUATOR MOVING CONTROL, REFER TO MANUALS FOR ALL THE NECESSARY INFORMATION AND CORRECT INSTALLATION AND MAINTENANCE OF THE PRODUCT.
- ⚠ BEFORE TO PROCEED TO THE ELECTRIC CONNECTION, MAKE SURE THE SUPPLY VOLTAGE IS TURNED OFF.
- ⚠ BEFORE TO TURN-ON THE MOTOR, MAKE SURE THE ELECTRIC CONNECTIONS ARE TIGHTENED AND STABLE.
- ⚠ CHECK POWER SUPPLY CABLES NOT TO BE DAMAGED DURING THE COMMISSIONING. POWER SUPPLY CABLES MUST BE OUT OF HEAT SOURCES AND MOVING ORGANS.
- ⚠ DURING FUNCTIONING ARE PRODUCED MAGNETIC, ELECTRIC AND ELECTROMAGNETIC FIELDS. THIS MAY BE DANGEROUS FOR PEOPLE THAT USE CARDIAC STIMULATOR (PACEMAKER), IF NOT SUFFICIENT DISTANCE.
- ⚠ DO NOT DISCONNECT ANY CONNECTION DURING OPERATION OR IN PRESENCE OF SUPPLY VOLTAGE.
- ⚠ BEFORE TO TURN-ON THE MOTOR, MAKE SURE THE MECHANICAL CONNECTIONS OF THE ACTUATOR REMAIN TIGHTENED AND STABLE, ALSO DURING THE OPERATION.
- ⚠ DURING THE COMMISSIONING, UNEXPECTED MOVEMENT OF THE MOTOR MAY BE CAUSED BY:
 - WIRING ERRORS
 - MOUNTING ERRORS
 - DAMAGES ON POWER SUPPLY CABLES
 - HARDWARE OR SOFTWARE ERRORS
 - DRIVER PARAMETERS ERRORS
 - OPERATION IN CONDITIONS OUTSIDE THE SPECIFICATIONS PROVIDED BY THE CATALOG AND THIS MANUAL
- ⚠ MAKE SURE THE SAFETY PROTECTION OF THE MACHINE (MECHANICAL AND ELECTRICAL) ARE ACTIVE.
- ⚠ DURING OPERATION, TEMPERATURE OF THE EXTERNAL SURFACE OF MOTORS CAN REACH HIGH TEMPERATURES. HOT SURFACES ON ACTUATOR CAN CAUSE BURNS AND SHOULD NOT BE TOUCHED.

6.2 FCP inductive proximity stroke limit switches

The INDUCTIVE PROXIMITY STROKE LIMIT SWITCHES allow the actuator to stop before reaching the internal mechanical stop avoiding damage. If intermediate sensors are present, they can be used to fix intermediate positions along the actuator stroke length. The inductive proximity stroke end switches are fixed directly on the actuator outer tube in the required position.

- The switches position is not adjustable.
- The positions of the two limit switches are the extreme travel positions Lc and La (see Fig. 6.6).
- FC 1 – sensor for RETRACTED ACTUATOR Lc position
- FC 2 – sensor for EXTENDED ACTUATOR La position

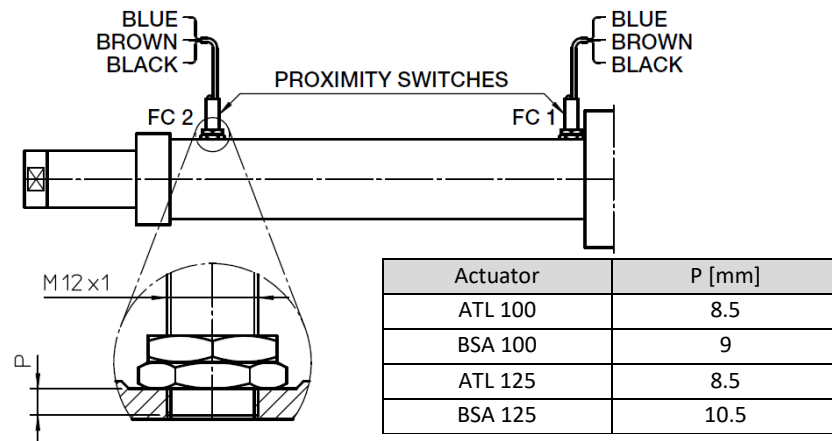
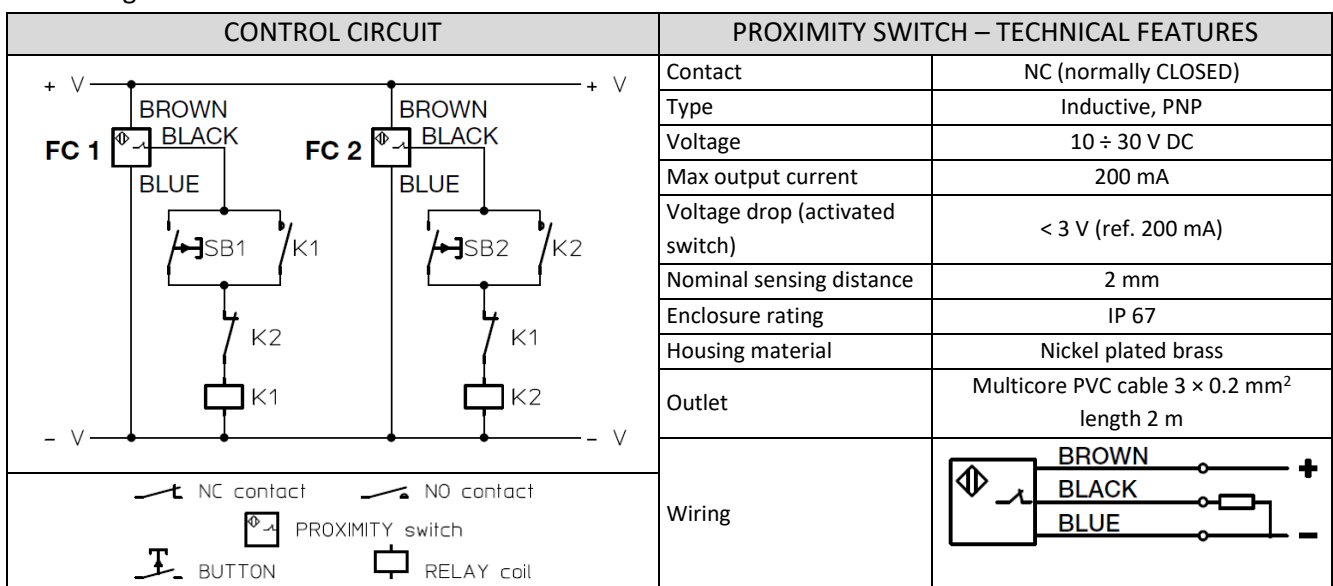

Figure 6.1 – FCP inductive proximity stroke limit switches

- Proximity switches are supplied already mounted on the actuator and set to the correct sensing distance.
- ⚠ DO NOT CHANGE THE SENSING DISTANCE OF PROXIMITY SWITCHES BY MOVING THE TWO NUTS FIXED ON THE SENSOR.
- In case it is necessary to restore the correct sensing distance position, please refer to Fig. 6.1.

The PROXIMITY STROKE LIMIT SWITCHES must be connected to the electric control circuit as shown in the following WIRING DIAGRAM:



- ⚠ DO NOT TRAVEL OVER THE STROKE LIMIT SWITCHES POSITIONS, AVOIDING TO REACH MECHANICAL STOP AND PREVENTING DAMAGE TO THE INTERNAL COMPONENTS OF THE ACTUATOR.

6.3 FC electric stroke limit switches

The ELECTRIC STROKE END SWITCHES FC allow to limit the actuator stroke avoiding to reach the extreme positions (mechanical stops) and preventing damage. The device consists of two switch assemblies, each of them consisting of one miniature electric switch (FC 1, FC 2) fixed to the relative support, a switch operating cam, rotating around the relative support pin when operated by the actuator nut, and a spring that allows the return of the cam to its neutral position, thus deactivating the switch; the entire assembly is covered by a cover and sealed by a rubber seal.

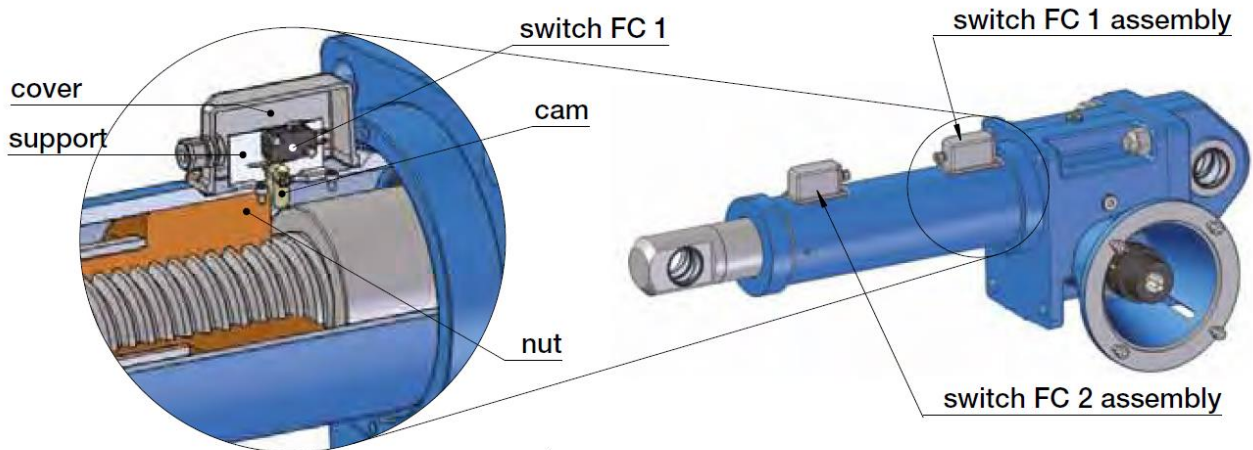

- The activation positions of the two limit switches are the extreme travel positions Lc and La (see Fig. 6.6).
- FC 1 – sensor for RETRACTED ACTUATOR Lc position
- FC 2 – sensor for EXTENDED ACTUATOR La position

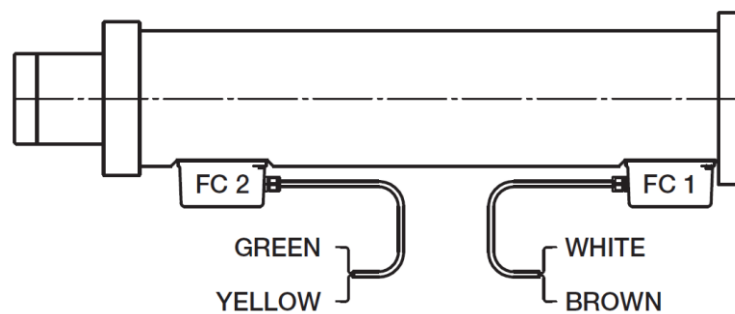

Figure 6.2 – electric stroke limit switches FC

- The position of the assembly along the outer tube is not adjustable.
- The device cannot be used to fix any intermediate position.

The ELECTRIC STROKE LIMIT SWITCHES must be connected to the electric control circuit as shown in the following WIRING DIAGRAM:

CONTROL CIRCUIT	ELECTRIC SWITCH - TECHNICAL FEATURES			
	Contact	NC (normally closed)		
	Supply voltage	250 V AC	125 V AC	125 V DC
	Current (resistive load)	16 A	16 A	0.6 A
	Current (inductive load)	10 A	10 A	0.6 A
	Output	2 PVC multicore cables 2 × 0.75 mm ² length 1.5 m		
	Wiring			

⚠ DO NOT TRAVEL OVER THE STROKE LIMIT SWITCHES POSITIONS, AVOIDING TO REACH MECHANICAL STOP AND PREVENTING DAMAGE TO THE INTERNAL COMPONENTS OF THE ACTUATOR.

6.4 Rotary encoder ENC.4

Encoder ENC.4 – TECHNICAL FEATURES	
Transducer type	Hall-effect encoder, incremental, bi-directional
Resolution	4 pulses per revolution
Output	PUSH-PULL 2 channels (A and B, phase difference 90°)
Input voltage	8 ÷ 32 V DC
Max commutable current I _{OUT}	100 mA
Max output voltage drop	with load connected to 0 and I _{OUT} = 100 mA: 4.6 V with load connected to + V and I _{OUT} = 100 mA: 2 V
Protection	against short circuit against input polarity inversion against any incorrect output connection
Cable length	1.3 m
Enclosure rating	IP 55

The rotary encoder ENC.4 must be connected to the electric control circuit as shown in the following WIRING DIAGRAM:

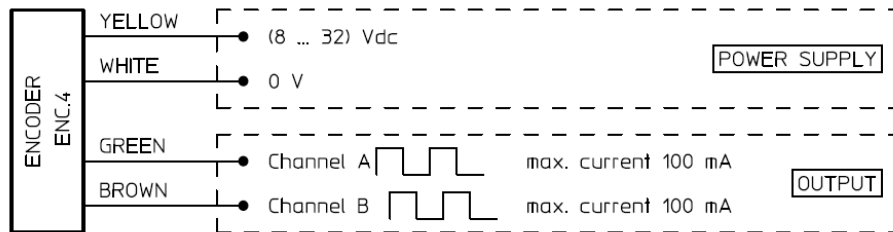

6.5 Rotary encoder EH53

Encoder EH53– TECHNICAL FEATURES	
Transducer type	Optical encoder, incremental, bi-directional
Resolution	100 or 500 pulses per revolution
Output	PUSH-PULL 2 channels (A and B, phase difference 90°) channel ZERO
Input voltage	8 ÷ 24 V DC
No-load current	100 mA
Max commutable current	50 mA
Cable length	0.5 m
Enclosure rating	IP 54

The rotary encoder ENC.4 must be connected to the electric control circuit as shown in the following WIRING DIAGRAM:

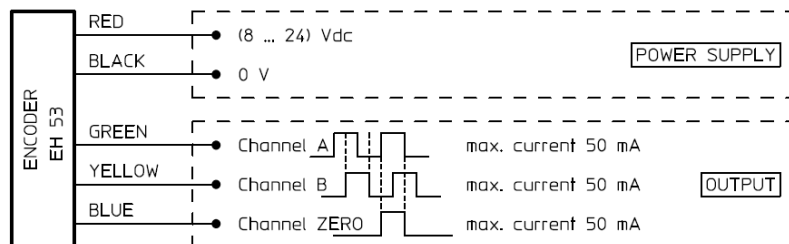

6.6 Servomotor assembly

Actuators with servomotor fitting are equipped with elastic zero backlash coupling as shown in the figure.

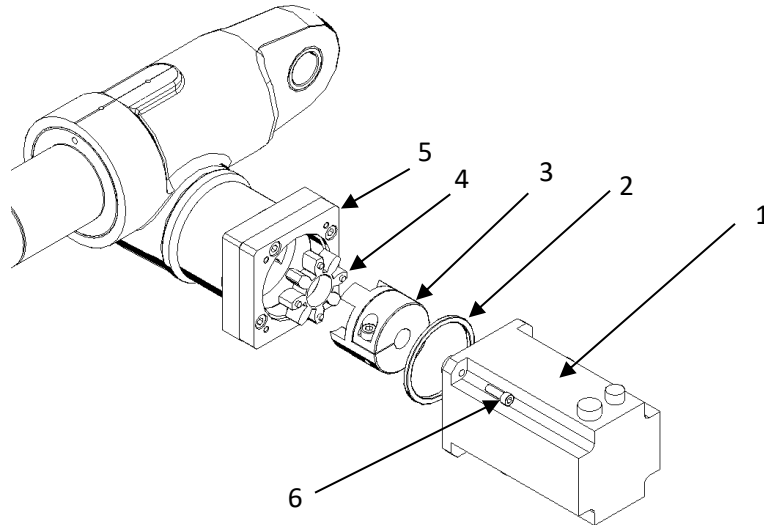

To assemble the servomotor on the actuator please follow the procedure:

- If present, place the centering ring (2) on the motor flange (1).
- Place the hub (3) on the motor shaft at distance L from the flange, as indicated in Tab. 6.3.
- Clamp the hub (3) on the shaft by applying tightening torque T specified in Tab. 6.3.
- Install the motor (1) with hub (3) and elastic spider (4) inside the bell (5), rotating the shaft if necessary in order to couple the hub on the actuator side.
- ⚠ To verify the correct positioning of the coupling, check the motor flange is in contact with the bell without forcing the motor shaft.
- Fix the motor (1) on the bell (5) with proper screws (not supplied with the actuator).

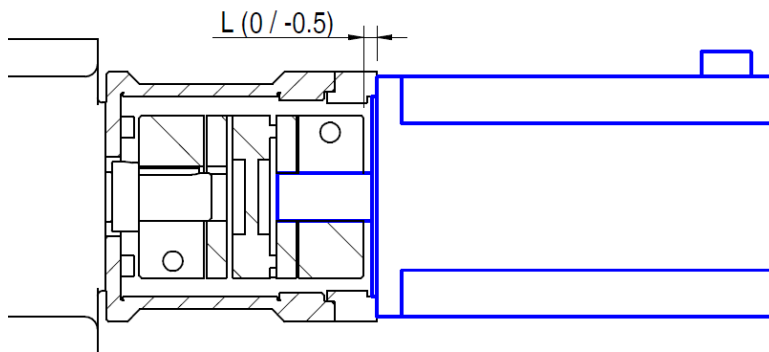

	Flange code	Motor shaft $\varnothing D \times L$ [mm]	L [mm]	T [Nm]
ATL/BSA 100	F1	$\varnothing 32 \times 60$	12.5	70
	F2	$\varnothing 35 \times 65 - \varnothing 35 \times 70$	12.5	70
		$\varnothing 35 \times 79 - \varnothing 35 \times 80 - \varnothing 42 \times 79$	24.5	70
		$\varnothing 42 \times 113$	55.5	70
	F3	$\varnothing 28 \times 60 - \varnothing 32 \times 58$	12.5	70
$\varnothing 38 \times 80 - \varnothing 42 \times 82$		24.5	70	
ATL/BSA 125	F1	$\varnothing 28 \times 60 - \varnothing 32 \times 58$	8	120
		$\varnothing 38 \times 80 - \varnothing 42 \times 82$	18	120
	F2	$\varnothing 42 \times 110 - \varnothing 55 \times 110$	54	120
	F3	$\varnothing 65 \times 130$	65	120
	F4	$\varnothing 48 \times 110 - \varnothing 55 \times 110$	45	120

Table 6.3 – Servomotor assembly

6.7 Electric motor wiring

AC 3-phase asynchronous motor

Connect the motor to the power unit of the plant or to the driver according to the following wiring diagrams, related to the motor type:

- (a) AC 3-phase motor without brake
- (b) AC 3-phase motor with DC brake directly powered with rectifier
- (c) AC 3-phase motor with 3-phase brake directly powered
- (d) AC 3-phase motor with DC brake separately powered AC 1-phase with rectifier
- (e) AC 3-phase motor with AC 3-phase brake separately powered
- (f) AC 3-phase motor with DC brake separately powered AC 2-phase with rectifier
- (g) AC 3-phase motor with DC brake separately powered

In case of brake motor:

- the brake is NORMALLY CLOSED (NEGATIVE action). When the power supply is switched off, the brake is engaged. The brake opens only when power is supplied;
- if the brake is wired directly to the connecting pins of the terminal box, it does not require any power supply;
- if the brake is wired separately, make sure that the correct voltage is used;
- if the brake is equipped with hand release device, make sure that the brake is engaged before starting the linear actuator.

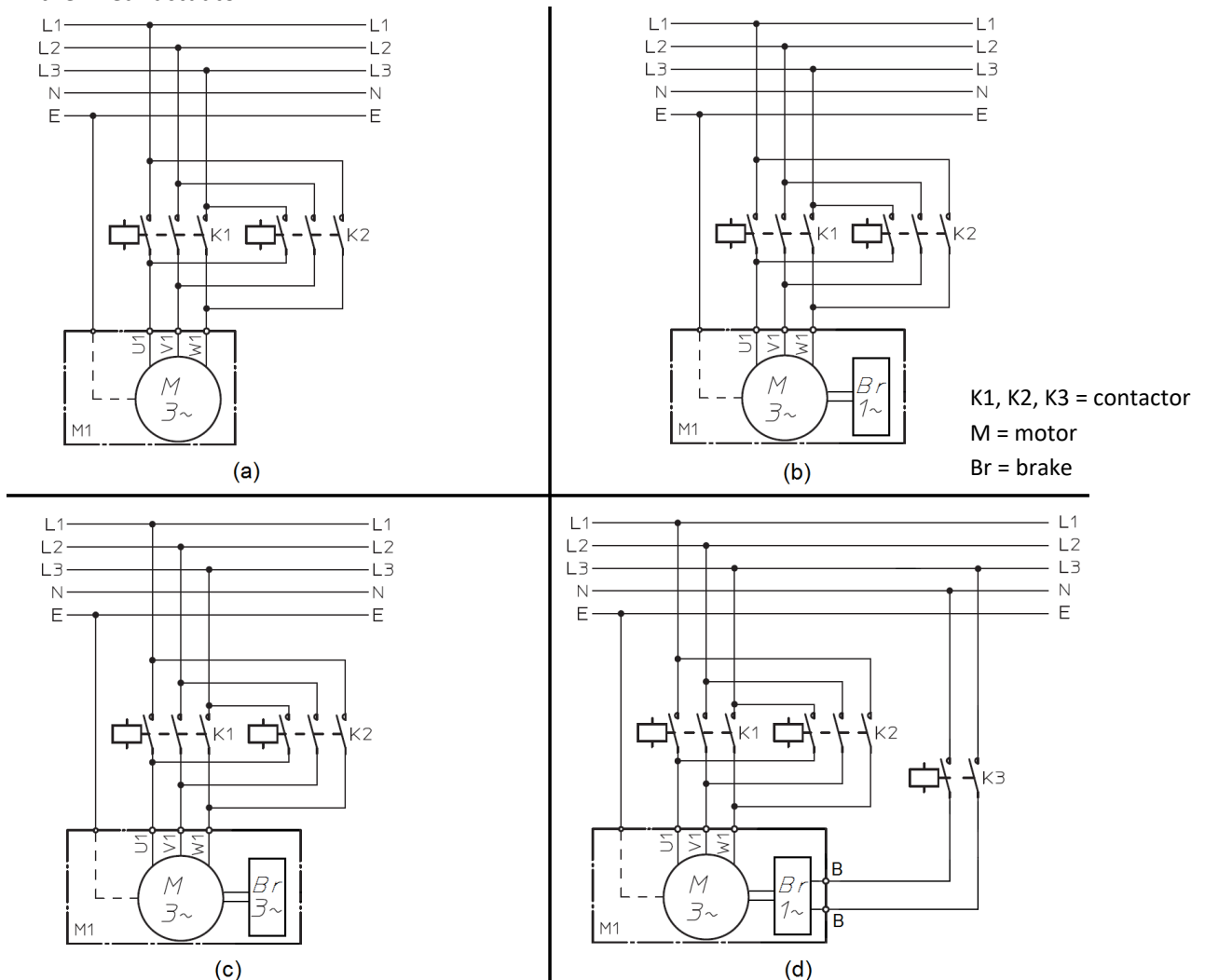

Figure 6.4 – Electric wiring diagrams to power supply of AC 3-ph motor

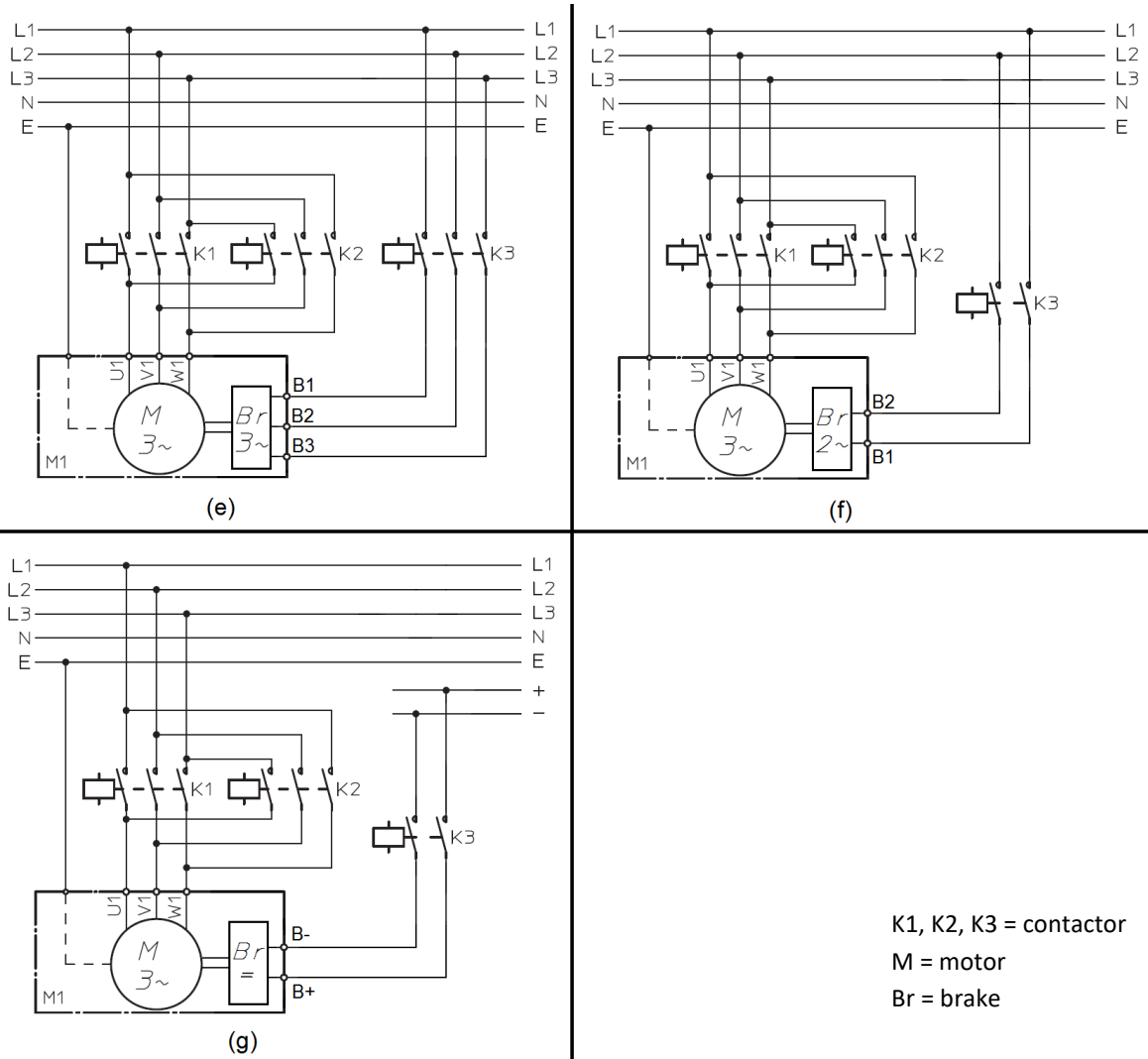

Figure 6.4 – Electric wiring diagrams to power supply of AC 3-ph motor

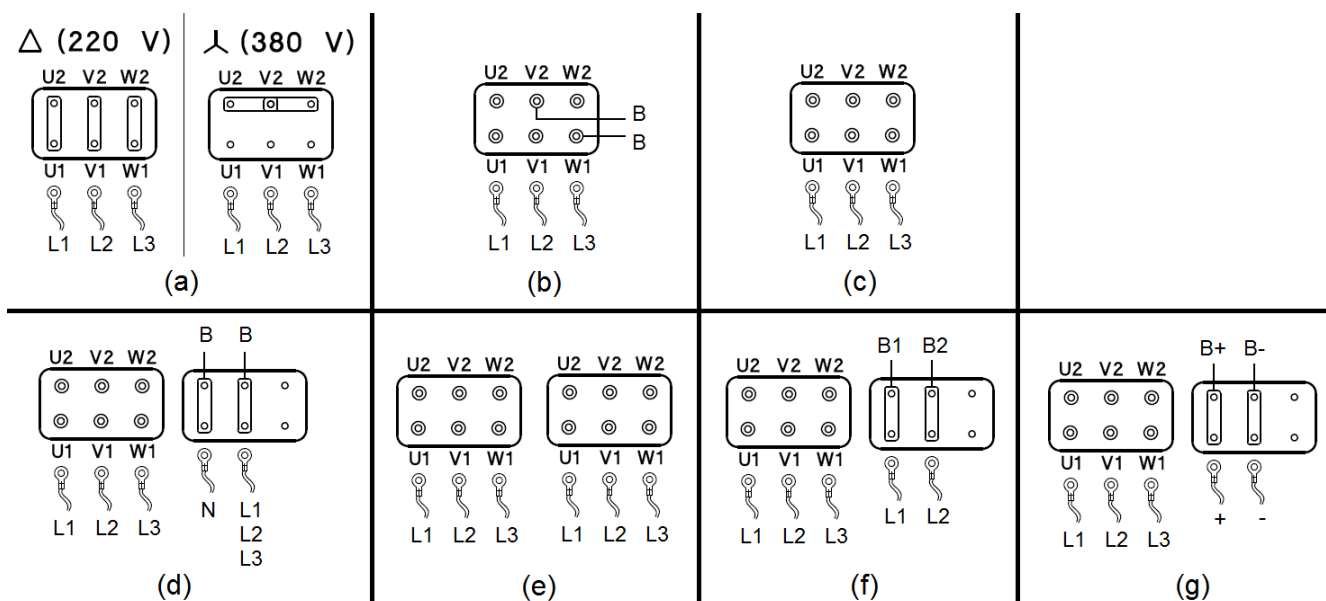

Figure 6.5 – Electric wiring diagrams to motor terminal board of AC 3-ph motor

⚠ IN CASE OF ELECTRIC MOTOR DIFFERENT FROM THE ABOVE MENTIONED, PLEASE REFER TO INSTALLATION INSTRUCTIONS SUPPLIED BY THE MANUFACTURER.

- Check if the push rod shifting direction is compatible to the indications on the control unit, by powering the electric motor on VERY BRIEFLY.

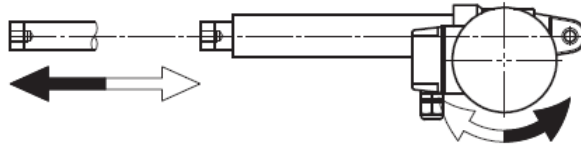

Figure 6.6 – Push rod shifting directions

- If the push rod shifting directions are not compatible: invert any wire pair (U1 ↔ V1, or U1 ↔ W1, or V1 ↔ W1) into the terminal board;

6.8 Linear actuator installation

- ⚠ THE BALL SCREW LINEAR ACTUATOR (**BSA** SERIES) IS NOT SELF-LOCKING. BEFORE TO APPLY ANY AXIAL LOAD ON THE PUSH ROD, LOCK THE INPUT SHAFT OR USE THE MOTOR BRAKE.
- ⚠ ALL MECHANICAL AND ELECTRICAL PROTECTION MUST BE INSTALLED AND ACTIVATED TO PREVENT DAMAGE TO PERSONS OR PROPERTY.

- Check that all plant fixing elements are well machined and cleaned, and that they fit the dimensions of the actuators fixing elements they have to be fixed to.
- If the length of the actuator have to be changed (push rod more retracted or extended) during installation, power the motor with limited speed and torque values, in order to avoid possible damages in case of a mechanical stop is reached.
- In case of actuators without anti-rotation device (AR), it is possible to manually screw/unscrew the push rod to change the length of the actuator.
- In case of actuators with bellow protection (B): DO NOT TWIST THE BELLOW.
- ⚠ DO NOT SET THE LENGTH OF THE ACTUATOR OVER ITS EXTREME VALUES:
 - “Lc” = RETRACTED ACTUATOR
 - “La” = EXTENDED ACTUATOR

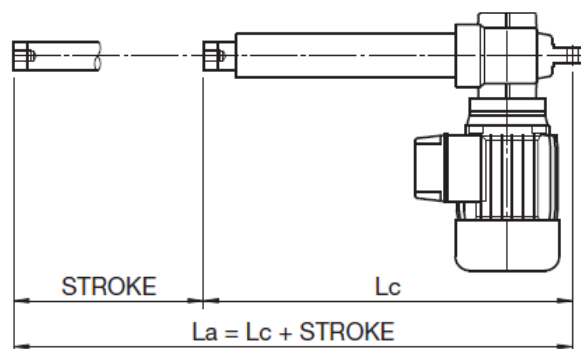

Figure 6.7 – “Lc” and “La” dimensions

Dimensions “Lc” and “La” are indicated in the technical catalogue of the product and on the check sheet supplied with the actuator.

- Fit the actuator to the plant in order to have ONLY axial load applied to the actuator.
- Check the correct alignment between front and rear pins: they must be PARALLEL.
- Check the correct alignment between the actuator and the moving parts.

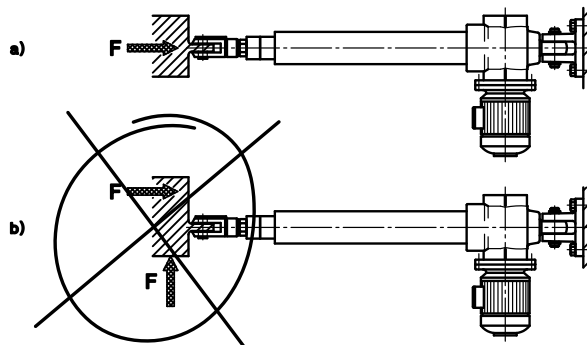

Figure 6.8 – Load on actuator: a) correct; b) not correct

- ⚠ RIGHT WORKING OF THE ACTUATOR AND PLANT CANNOT BE GUARANTEED IF SIDE OR NOT AXIAL LOAD ARE APPLIED TO THE ACTUATOR.

6.9 Installation of rod end fitting elements

- To install a fitting element on the rod end threaded bore (BA) fix the push rod with a clamp to counterhold the locking torque.
- ⚠ In case of actuator equipped with AR (anti-rotation) device: DO NOT TRANSFER ANY TORQUE TO THE PISTON ROD.
- ⚠ WARNING: in case of torque transfer into the actuator with AR device, the internal mechanical components can be damaged.
- Fix the threaded element with Loctite 270.
- To unmount the element, heat the threaded area to unlock it.
- Unscrew the fitting element counterholding the torque on the push rod.

7 COMMISSIONING AND USE

SERVOMECH linear actuators are supplied lubricated and ready to be used. Before to start commissioning and activation, the following checks must be carried out:

Shifting direction check

- Check if the push rod shifting direction is compatible to the indications on the control unit, by powering the electric motor on VERY BRIEFLY. If not, see Section 6.7.
- ⚠ For actuator without ANTI-ROTATION device (AR): TO ALLOW THE TRANSLATION OF THE ROD END, THE PUSH ROD ROTATION MUST BE REACTED BY USING EXTERNAL GUIDES.

Check of extreme working positions

- Check if the extreme dimensions of the actuator “Lc” and “La” (see Fig. 6.7) are compatible with extreme positions of the plant component that has to be moved.
- Measure the initial length of the actuator, then run the actuator GRADUALLY from the control unit, in order to reach the plant to its more distant extreme position.
- Check continuously the current actuator length during the motion.
- Repeat the same procedure for the other extreme position.

⚠ TO AVOID DAMAGES, DO NOT TRAVEL OVER THE EXTREME STROKE VALUES Lc and La!

⚠ DO NOT REACH STROKE END MECHANICAL STOP!

Commissioning

At this stage it is possible to start commissioning:

- Carry out one complete working cycle, without load.
 - Carry out some complete working cycles, increasing gradually the load, until full load is reached.
- ⚠ ONLY IN CASE ON **ATL ACTUATOR** (ACME SCREW DRIVE): DURING COMMISSIONING, DO NEVER EXCEED THE MAX ALLOWED DUTY CYCLE FOR THE LINEAR ACTUATOR **30% OVER 10 MIN** TIME PERIOD AT 25°C ENVIRONMENT. ANY ABUSE OF SUCH DUTY CYCLE CAN CAUSE OVERHEATING AND UNINTENTIONAL PREMATURE DAMAGING!

8 LUBRICATION

SERVOMECH linear actuators ATL/BSA series are supplied lubricated, with lubricants indicated in the table below.

ACTUATOR	GEARBOX	LINEAR DRIVE	PUSH ROD GUIDE REAR HINGE
ATL 100	Grease (NLGI 00 DIN 51818): AGIP Grease SLL 00	Grease (NLGI 2 DIN 51818): ENI Grease SM 2 Also suitable: SHELL Gadus S2 V220D 2 (NLGI 2) MOBIL Mobilgrease XHP 222 Special (NLGI 2) FUCHS Renolit FLM 2 (NLGI 2)	
ATL 125			
BSA 100	Grease (NLGI 00 DIN 51818): AGIP Grease SLL 00	Grease (NLGI 1 DIN 51818): LUBCON Thermoplex ALN 1001 Also suitable: FUCHS Renolit DURAPLEX EP 2 (NLGI 2) AGIP Grease AC 1 (NLGI 1) MOBIL Mobilgrease FM 101 (NLGI 1) KLUBER Klubersynth UH1 14-151 (NLGI 1)	
BSA 125			

Table 8.1 – Lubricants

- ⚠ DO NOT USE LUBRICANTS DIFFERENT FROM THOSE ABOVE MENTIONED.
- ⚠ DO NOT MIX INCOMPATIBLE GREASES.
- ⚠ IF DIFFERENT LUBRICANT SHOULD BE USED, PLEASE CONTACT SERVOMECH BEFORE PROCEED.
- ⚠ IN CASE OF CUSTOM PRODUCT EXECUTION, THE LUBRICANTS COULD BE DIFFERENT FROM THE STANDARD ABOVE. TO KNOW THE LUBRICANT TYPE PLEASE REFER TO THE PRODUCT CHECK SHEET SUPPLIED WITH THE PRODUCT.

9 MAINTENANCE

- The gearbox is long-life lubricated and will not require any further relubrication.
- The linear drive requires periodic relubrication, according to Table 9.1, or at the latest after 1 year of time. Please use lubricant indicated in Table 8.1 or equivalent.
- Every 2 months time interval: visual inspections of actuator conditions, cleaning of dirty parts of the actuator.
- In case of lubricant leakage, contact SERVOMECH.

ACTUATOR	Lead pitch [mm]	Lubrication interval [km of stroke]	Linear drive lubr. q.ty		Push rod guide lubr. q.ty	Rear hinge lubr. q.ty
			Q.ty for actuator stroke 100mm	Q.ty for each additional 100mm of stroke		
ATL 100	12	12	17 cm ³	7 cm ³	17 cm ³	Until filled
	24	24				
ATL 125	12	12	28 cm ³	11 cm ³	37 cm ³	Until filled
	24	24				
BSA 100	16	160	15 cm ³	7 cm ³	17 cm ³	Until filled
	20	200	16 cm ³	7 cm ³		
BSA 125	16	160	21 cm ³	8 cm ³	37 cm ³	Until filled
	20	200	21 cm ³	9 cm ³		

Table 9.1 – Maintenance

9.1 Linear drive lubrication

⚠ WARNING! THE PLANT MUST BE STOPPED BEFORE BEGINNING ANY MAINTENANCE OPERATION.

- Before to start relubrication, put the actuator in extended position (La – see Fig. 6.7)
- Relube the linear actuator using proper grease nipples, as shown on Fig. 9.2
- Grease nipple type: DIN71412 M6

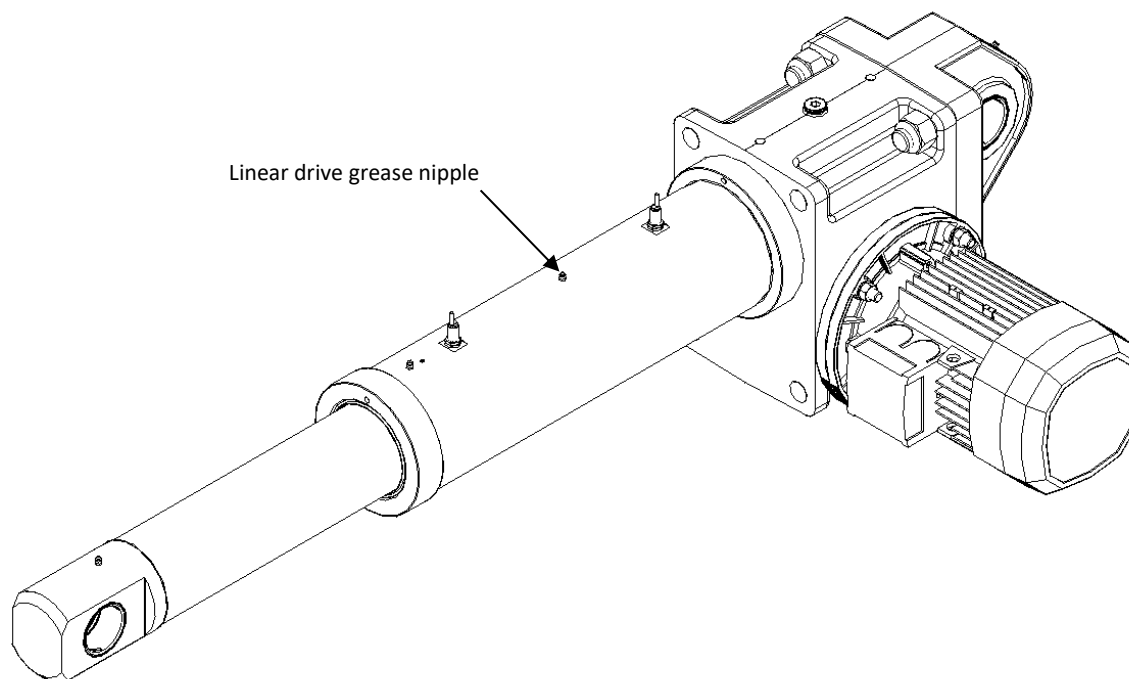

Figure 9.2 – Linear drive relubrication

- Apply the grease quantity indicated in Tab 9.1 with several partial quantities.
 - Travel over the entire stroke between one lubricating operation and the next.
- ⚠ WHEN LUBRICATING THE LINEAR DRIVE, THE ACTUATOR MUST ALWAYS BE IN EXTENDED (La) POSITION. DO NOT LUBRICATE THE LINEAR SCREW DRIVE IN RETRACTED (Lc) OR INTERMEDIATE POSITIONS!
- ⚠ IN CASE OF STROKE LENGTH ≥ 500 mm, 2 OR MORE GREASE NIPPLES FOR THE LINEAR DRIVE LUBRICATION ARE PLACED ON ACTUATOR. EQUALLY SPLIT THE TOTAL LUBRICANT QUANTITY (SEE TABLE 9.1) BETWEEN THE GREASE NIPPLES.
- ⚠ DO NOT CONFUSE THE LINEAR DRIVE GREASE NIPPLE WITH THE PUSH ROD GUIDE GREASE NIPPLE (SEE SECTION 9.2 “PUSH ROD GUIDE LUBRICATION”).
- At the end of lubricating procedure, extend and retract the push rod over its entire stroke for 3 full cycles.
 - If necessary, remove excess of lubricant from push rod.

9.2 Push rod guide lubrication

⚠ WARNING! THE PLANT MUST BE STOPPED BEFORE BEGINNING ANY MAINTENANCE OPERATION.

- Relube the push rod guide using proper grease nipple, as shown on Fig. 9.3.
- Grease nipple type: DIN71412 M6

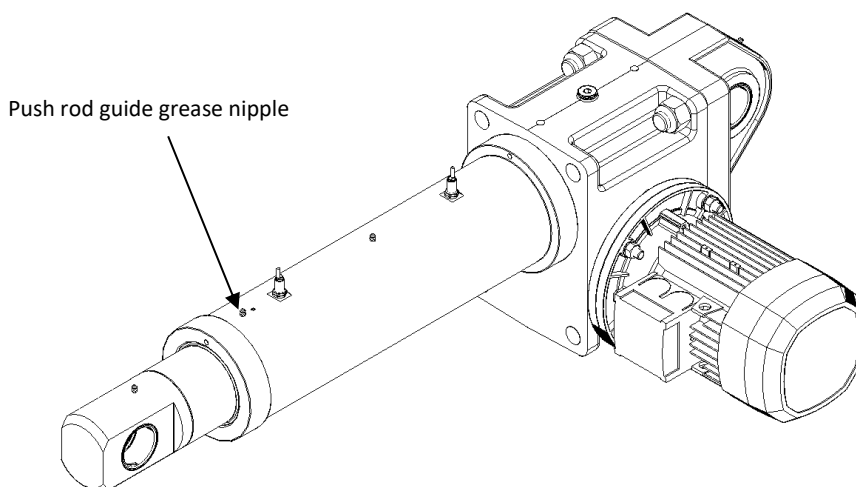

Figure 9.3 – Push rod guide lubrication

- Apply the grease quantity indicated in Tab 9.1.
- In case of extra guide option, 2 grease nipples are placed on the actuator. Lubricated both grease nipples with quantity indicated in Tab. 9.1.
- Extend and retract the push rod over its entire stroke for 3 full cycles.
- If necessary, remove excess of lubricant from push rod.

9.3 Rear hinge lubrication

⚠ WARNING! THE PLANT MUST BE STOPPED BEFORE BEGINNING ANY MAINTENANCE OPERATION.

- Relube the rear hinge using proper grease nipples (n°2 grease nipples, as shown on Fig. 9.4).
- Grease nipple type: DIN71412 M6

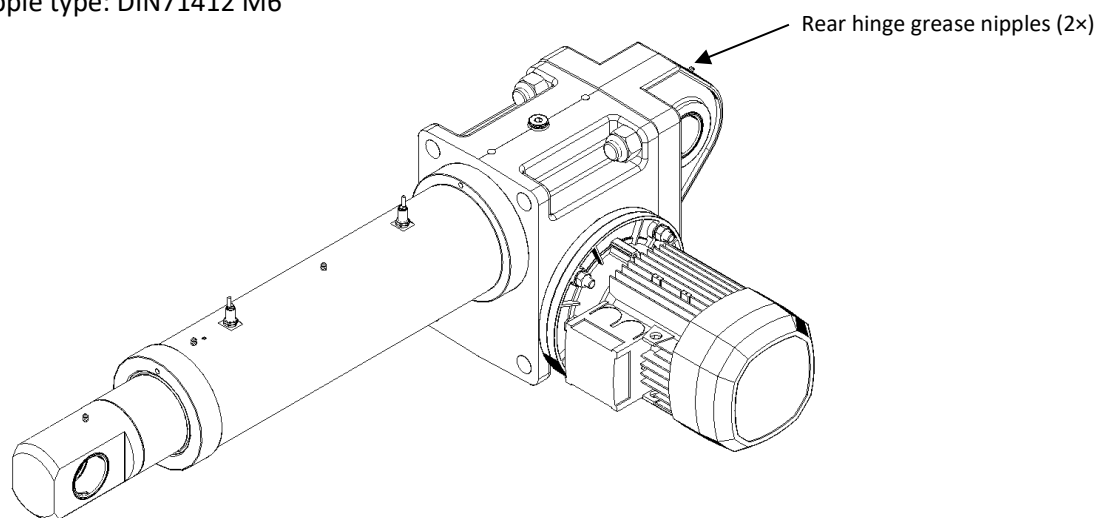

Figure 9.4 – Rear hinge lubrication

- Apply the grease until the steel bush is filled.
- If necessary, remove excess of lubricant from the hinge pin.

9.4 Hinged head TF lubrication

⚠ WARNING! THE PLANT MUST BE STOPPED BEFORE BEGINNING ANY MAINTENANCE OPERATION.

- Relube the hinged head using proper grease nipples, as shown on Fig. 9.4.
- Grease nipple type: DIN71412 M6

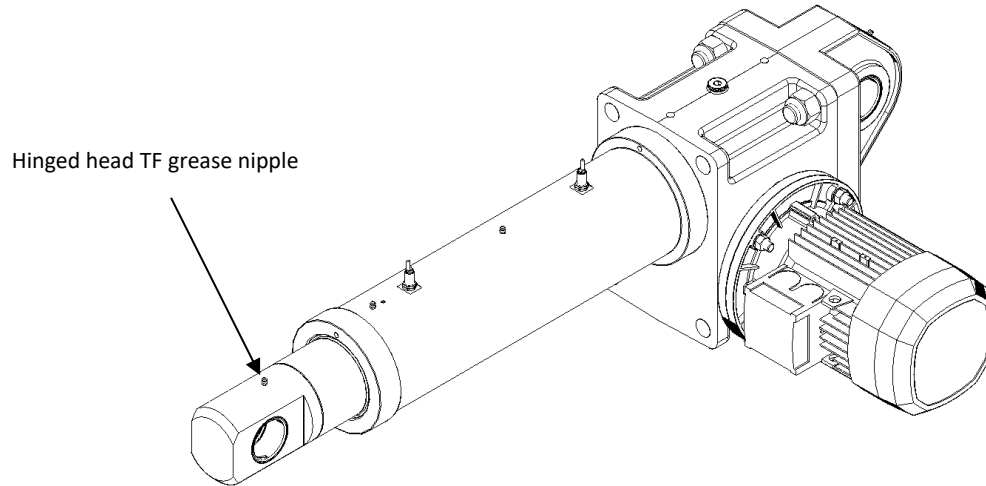

Figure 9.5 – Hinged head TF lubrication

- Apply the grease until the steel bush is filled.
- If necessary, remove excess of lubricant from the hinge pin.